

***TM 9-2320-360-20-3**

VOLUME NO. 3

**TECHNICAL MANUAL
UNIT MAINTENANCE**

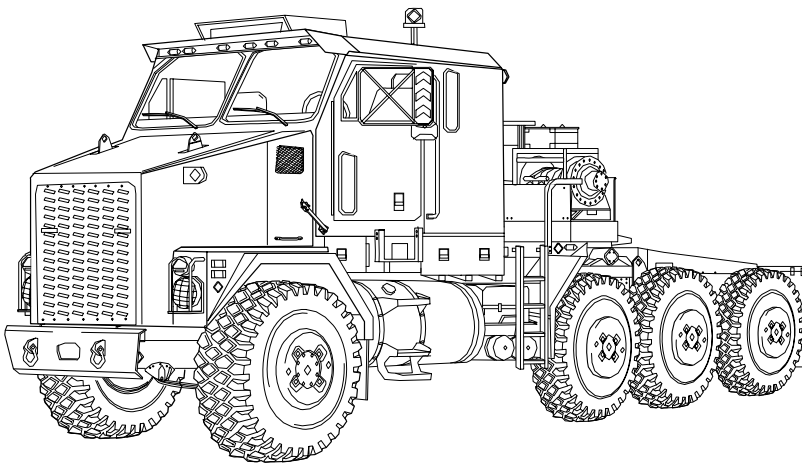

**HOW TO USE
THIS BOOK H-1**

**TESTING THE
DDEC III SYSTEM H-11**

**TROUBLESHOOTING
CHARTS H-40**

**DIAGNOSTIC
CODE
CHARTS H-103**

**DIAGNOSTIC DATA
READER
INFORMATION H-257**

**TRUCK, TRACTOR, M1070, 8 X 8,
HEAVY EQUIPMENT TRANSPORTER (HET)**

NSN 2320-01-318-9902

EIC: B5C

DISTRIBUTION STATEMENT A: Approved for public release; distribution is unlimited.

*Supersedes TM 9-2320-360-20-3 dated 01 September 1997

HEADQUARTERS, DEPARTMENT OF THE ARMY

May 2007

WARNING

CARBON MONOXIDE (EXHAUST GAS) CAN KILL YOU

Carbon monoxide is a colorless, odorless, DEADLY POISONOUS gas and when breathed deprives body of oxygen and causes SUFFOCATION. Breathing air with carbon monoxide produces symptoms of headache, dizziness, loss of muscular control, a sleepy feeling, and coma. Permanent BRAIN DAMAGE or DEATH may result from severe exposure.

The following precautions MUST be followed to ensure personnel are safe whenever personnel heater or main or auxiliary engine is operated for any purpose.

- DO NOT operate personnel heater or engine of vehicle in enclosed area without adequate ventilation.
- DO NOT idle engine for long periods without ventilator blower operation. If tactical situation permits, open hatches.
- DO NOT drive any vehicle with inspection plates, cover plates, or engine compartment doors removed unless necessary for maintenance purposes.
- NEVER sleep in a vehicle when the heater is operating or the engine is idling.
- BE ALERT at all times during vehicle operation for exhaust odors or exposure symptoms. If either are present, IMMEDIATELY EVACUATE AND VENTILATE the area. Affected personnel treatment shall be: expose to fresh air; keep warm; DO NOT PERMIT PHYSICAL EXERCISE; if necessary, give artificial respiration as described in FM 4-25.11 and get medical attention.
- BE AWARE; neither the gas particulate filter unit nor field mask for nuclear, biological, and chemical protection will protect you from carbon monoxide poisoning.

THE BEST DEFENSE AGAINST CARBON MONOXIDE POISONING IS GOOD VENTILATION.

WARNING

Personnel hearing can be PERMANENTLY DAMAGED if exposed to constant high noise levels of 85 dB (A) or greater. Wear approved hearing protection devices when working in high noise level areas. Personnel exposed to high noise levels shall participate in a hearing conservation program in accordance with DA PAM 40-501. Hearing loss occurs gradually but becomes permanent over time.

WARNING

Wear eye protection and use care when replacing snap rings and retaining rings. Snap/retaining rings are under spring tension and can act as projectiles when released and may cause severe eye injury.

WARNING

Fuel and oil are slippery and can cause falls. To avoid injury, wipe up spilled fuel or oil with rags.

WARNING

- Adhesive -sealants and sealing compounds can burn easily, can give off harmful vapors, and are harmful to skin and clothing. To avoid injury or death, keep away from open fire and use in well-ventilated area. If sealing compound gets on skin or clothing, wash immediately with soap and water.
- Adhesive causes immediate bonding on contact with eyes, skin, or clothing and also gives off harmful vapors. Wear protective goggles and use in well-ventilated area. If adhesive gets in eyes, try to keep eyes open; flush eyes with water for 15 minutes and get immediate medical attention.
- On direct contact, uncured silicone sealant irritates eyes. In case of contact, flush eyes with water and seek medical attention. In case of skin contact, wipe off and flush with water.

WARNING

- Dry cleaning solvent P-D-680 is toxic and flammable. Wear protective goggles and gloves and use only in a well-ventilated area. Avoid contact with skin, eyes, and clothes, and don't breathe vapors. DO NOT use near open flame or excessive heat. The flash point is 100-138°F (38-59°C). If you become dizzy while using cleaning solvent, get fresh air immediately and medical aid. If contact with eyes is made, wash your eyes with water and get medical aid immediately.
- Compressed air for cleaning purposes will not exceed 30 psi (207 kPa). Use only with effective chip guarding and personal protective equipment (goggles/shield, gloves, etc.).
- Steam cleaning creates hazardous noise levels and severe burn potential. Eye, skin, and ear protection is required. Failure to comply may result in injury to personnel.
- Face shield must be used by personnel operating spray gun. Failure to comply may result in injury to personnel.

WARNING

When servicing this vehicle, performing maintenance, or disposing of materials such as engine coolant, transmission fluid, lubricants, batteries, battery acid or CARC paint, consult your Unit/local hazardous waste disposal center or safety office for local regulatory guidance. If further information is needed, please contact the Army environmental hotline at 1-800-872-3845. Improper disposal of this material may result in damage to environment or injury to personnel.

WARNING

Observe the following precautions when working on or around engine/transmission components.

- Ensure engine is cool before performing maintenance. Failure to comply may result in severe burns.
- Use caution when draining hot oil. Oil may burn exposed skin and cause injury to personnel. If injured, seek medical attention immediately.
- Never use magnetic plug in center of engine oil pan to drain oil. Failure to comply may result in injury to personnel and could cause oil to drain on vehicle components.
- When working on a running engine, use caution around rotating parts. Tools, clothing, and hands may get caught causing serious injury or death to personnel.
- Use caution when working near hood mounting bracket that extends beyond firewall. Failure to comply may result in injury to personnel.
- Parking brake must be applied, with transmission range selector and transfer case in neutral before starting DDR cylinder cutout test. Failure to comply may result in vehicle moving unexpectedly and injury to personnel.

WARNING

Observe the following precautions when working around fuel.

- Fuel is very flammable and can explode easily. To avoid serious injury or death, keep fuel away from open fire and keep fire extinguisher within easy reach when working with fuel. Do not work on fuel system when engine is hot. Fuel can be ignited by hot engine. When working with fuel, post signs that read NO SMOKING WITHIN 50 FEET OF VEHICLE.
- Never use fuel to clean parts. Fuel is highly flammable. Serious personnel injury could result if fuel ignites during cleaning.
- Starting fluid is toxic and highly flammable. Container is pressurized. Never heat container or discharge starting fluid in confined areas or near open flame. Failure to comply may result in injury to personnel. If injured, seek immediate medical attention.
- Ether is very flammable and could explode causing serious injury or death. Keep ether cylinders away from heat and open flame.

WARNING

Observe the following precautions when working on or around exhaust system components.

- Ensure exhaust pipe, tube, and muffler are cool before performing maintenance. Failure to comply may result in serious personal injury.
- Do not operate HET Tractor with muffler removed. Toxic exhaust fumes may enter cab, resulting in injury or death to personnel.
- Muffler weighs 91 lb (41 kg). Assistant is required when replacing muffler. Failure to comply may result in injury to personnel.
- Support tail pipe guards when replacing mounting hardware to prevent from falling, possibly causing injury to personnel.

WARNING

Observe the following precautions when working on or around cooling system components.

- Coolant and radiator may be very hot and under pressure from engine operation. Ensure engine and radiator are cool before performing maintenance. Failure to comply may cause serious injury.
- Keep out from under radiator while supported by lifting device to prevent serious injury.
- Keep out from under fan while removing it to prevent serious injury.

WARNING

Observe the following precautions when working on or around electrical system components.

- Remove rings, bracelets, watches, necklaces, and any other jewelry before working around HET Tractor. Jewelry can catch on equipment and cause injury or short across electrical circuit and cause severe burns or electrical shock. Batteries can explode from a spark. Battery acid is harmful to skin and eyes. Always wear eye protection when working with batteries.
- Batteries must be disconnected before checking cables and wires on starter or tightening any connections. Failure to comply may result in injury to personnel.
- Battery acid (electrolyte) is extremely harmful. Always wear safety goggles and rubber gloves and do not smoke when performing maintenance on batteries. Injury will result if acid contacts skin or eyes. Wear rubber apron to prevent clothing being damaged.
- Never use open flame to apply heat to heatshrink tubing. Failure to comply may result in injury to personnel.
- Allow solder to cool before handling. Failure to comply may result in injury to personnel.
- Allow heatshrink tubing to cool before handling. Failure to comply may result in injury to personnel.
- Starter weighs 72 lb (33 kg) and is difficult to handle. To prevent injury, use caution when removing.

WARNING

Support propeller shaft while performing maintenance. Personnel may be injured if propeller shaft falls.

WARNING

Observe the following precautions when working on or around brake system components.

- Brake shoes may be coated with dust. Breathing dust may be harmful to personnel. Wear filter mask approved for use against brake dust.
- Do not allow grease or oil to contact brake linings. Linings can absorb grease and oil, causing early glazing and very poor brake action. Failure to comply may result in serious injury or death to personnel.

WARNING

Observe the following precautions when working on or around brake system components (cont)

- All brakes must be adjusted when performing brake adjustment procedure. Failure to comply may cause improper braking and result in injury to personnel .
- Brake shoes are installed with strong spring tension. Keep hands clear when installing parts to prevent serious injury.
- Brake drum weighs 135 lb (61 kg). Assistance is required when replacing brake drum. Failure to comply may result in injury to personnel.
- When replacing brake shoes, all four shoes on an axle must be replaced at the same time. Failure to comply may result in improper brake operation and injury to personnel.
- Never attempt to remove upper spring brake clamp ring. Failure to comply will result in personnel injury or death.
- Never try to repair rear brake chamber. High spring tension makes repair dangerous. Severe injury or death may result.
- When working on parking brake control system vehicle may roll. Vehicle must be parked on level ground. Wheel chocks must be positioned in front of and behind one of the rear wheels to keep it from rolling. Failure to comply may result in injury or death to personnel.

WARNING

Observe the following precautions when working on or around wheels and tires.

- Hydraulic jack and jackstands must be positioned on flat surface. Placing jack or jackstands on unlevel or soft surface may result in truck falling and cause injury or death to personnel.
- If any loose or broken bolts are found after removing the wheel cover, deflate the tire completely before attempting to loosen lug nuts. Failure to comply may result in injury to personnel.
- Tire must be completely deflated before attempting to loosen nuts if any bolts are found loose or broken after removing wheel cover. Failure to comply may result in injury to personnel.
- High pressure air will be released from valve stem when core is removed. Stay clear of valve stem after core is removed. Failure to comply may result in personnel injury.
- Keep hands and fingers from between tire and bead lock. Failure to comply may result in injury to personnel.
- Tire may explode and cause serious injury or death. Place wheel and tire in safety cage before inflating. Stay back 10 ft (0.3 m) from cage when inflating. Minimum hose length is 10 ft (0.3 m).
- When conducting wheel runout check or wheel bearing check, HET Tractor must be on level ground and wheels must be chocked before parking brake is released. Otherwise, HET Tractor may roll and cause personnel injury.
- Wheel assembly weighs 523 lb (237 kg). Use caution when handling wheel. Failure to comply may result in serious injury or death to personnel.

WARNING

Observe the following precautions when working on or around steering components.

- Steering reservoir is heavy. Support steering reservoir while performing maintenance. Steering reservoir could fall resulting in injury to personnel.
- Support tee gear box before removing mounting screws to prevent injury.
- Tie rod end must be threaded into tie rod so that threads are beyond slot under clamp. Failure to comply may result in tie rod end separating from tie rod resulting in injury to personnel and loss of vehicle control.

WARNING

Observe the following precautions when working on or around cab and frame components.

- Hood springs may be under tension. Use care when replacing springs to prevent injury.
- Do not use hood as a work platform. Using hood as a work platform may result in injury to personnel and/or equipment damage.
- Hood weighs 235 lb (107 kg). Keep out from under hood. Hood could fall causing serious injury.
- Door is very heavy. If dropped, door may cause serious injury.
- Keep out from under spare wheel/tire carrier while supported by lifting device to prevent injury.

WARNING

Observe the following precautions when working on or around fifth wheel.

- Improper adjustment of fifth wheel may cause trailer to become uncoupled during operation. Serious injury or death may result.
- Fifth wheel plate must be secure before performing maintenance. Failure to do so may result in injury to personnel.
- Fifth wheel weighs 925 lb (420 kg). Use suitable lifting device to prevent injury to personnel.
- Ramp weighs 237 lb (108 kg). Keep out from under heavy parts. Falling parts may cause serious injury or death.

WARNING

Observe the following precautions when working on or around suspension system components.

- Air suspension will lower when air line/hoses are removed. To avoid injury, stay clear of HET Tractor frame until air suspension is completely lowered.
- Do not attempt to inflate air spring when it is removed from vehicle. Failure to comply may result in serious injury to personnel.
- Air suspension system may still be pressurized even though air pressure gage reads 0 psi. Remove air line slowly to allow air to escape. Failure to comply may result in air line blowing off causing serious injury to personnel.

WARNING

Observe the following precautions when working on or around winch system components.

- Always wear heavy duty gloves when handling winch cable. Never let cable run through hands. Frayed cable can cut hands severely.
- Use care when removing winch cable from drum. End of cable can spring up causing injury to personnel.
- Do not operate winch without guard in place.
- Do not place hands or feet near winch during operation.
- Auxiliary winch weighs approximately 130 lb (59 kg). Use lifting device to replace auxiliary winch. Failure to comply may result in injury to personnel.
- Control console panels are heavy. Use care when removing screws to avoid injury to personnel.

WARNING

Chemical Agent Resistant Coating (CARC) paint contains isocyanate (HDI) which is highly irritating to skin and respiratory system. High concentrations of HDI can produce symptoms of itching and reddening of skin, a burning sensation in throat and nose, and watering of the eyes. In extreme concentrations, HDI can cause cough, shortness of breath, pain during respiration, increased sputum production, and chest tightness. The following precautions must be taken whenever using CARC paint:

- DO NOT let skin or eyes come in contact with CARC paint. Always wear protective equipment (gloves, ventilation mask, safety goggles, etc.).
- NEVER weld or cut CARC-coated materials.
- DO NOT grind or sand painted equipment without high efficiency air purifying respirators in use.
- BE AWARE of CARC paint exposure symptoms; symptoms can occur a few days after initial exposure. Seek medical help immediately if symptoms are detected.

WARNING

After Nuclear, Biological, or Chemical (NBC) exposure of vehicle, all air filters shall be handled with extreme caution. Unprotected personnel may experience injury or death if residual toxic agents or radioactive material are present. If vehicle is exposed to chemical or biological agents, servicing personnel shall wear protective mask, hood, protective overgarments, and chemical protective gloves and boots in accordance with FM 3-11.4. All contaminated air filters shall be placed in double-lined plastic bags and moved swiftly to a segregation area away from the worksite. The same procedure applies for radioactive dust contamination. The Company NBC team should measure radiation prior to filter removal to determine extent of safety procedures required per the NBC Annex to the unit Standard Operating Procedures (SOP). The segregation area in which the contaminated air filters are temporarily stored shall be marked with appropriate NBC placards. Final disposal of contaminated air filters shall be in accordance with local SOP. Decontamination operation shall be in accordance with FM 3-11.5 and local SOP.

See FM 4-25.11 for additional first aid data.

LIST OF EFFECTIVE PAGES

Dates of issue for original pages

Original..... 31 May 2007

TOTAL NUMBER OF PAGES IN THIS PUBLICATION IS 311 CONSISTING OF THE FOLLOWING:

Page No.	* Change No.
Cover	0
blank.....	0
a thru f	0
A/ (B blank).....	0
i thru vi	0
H-1 thru H-288	0

* Zero In This Column Indicates An Original Page.

A/ (B blank)

Technical Manual
TM 9-2320-360-20-3

HEADQUARTERS
DEPARTMENT OF THE ARMY
WASHINGTON, D.C., 31 MAY 2007

UNIT MAINTENANCE

TRUCK, TRACTOR, M1070, 8 X 8, HEAVY EQUIPMENT TRANSPORTER (HET) (NSN 2320-01-318-9902) EIC:B5C

REPORTING ERRORS AND RECOMMENDING IMPROVEMENTS

You can help improve this publication. If you find any mistakes or if you know of a way to improve the procedures, please let us know. Submit your DA Form 2028 (Recommended Changes to Equipment Technical Publications) through the Internet on the Army Electronic Product Support (AEPS) Web site. The Internet address is <https://aeps.ria.army.mil>. The DA Form 2028 is located under the Public Applications section on the AEPS public home page. Fill out the form and click on SUBMIT. Using this form on the AEPS site will enable us to respond quicker to your comments and to better manage the DA Form 2028 program. You may also mail, fax, or e-mail your letter or DA Form 2028 directly to: TACOM Life Cycle Management Command, ATTN: AMSTA-LC-LPIT / TECH PUBS, 1 Rock Island Arsenal, Rock Island, IL 61299-7630. The e-mail address is ROCK-TACOM-TECH-PUBS@conus.army.mil. The fax number is DSN 793-0726 or Commercial (309) 782-0726.

DISTRIBUTION STATEMENT A: Approved for public release; distribution is unlimited.

TABLE OF CONTENTS

	Page
APPENDIX H DDEC III/IV DIAGNOSTIC TROUBLESHOOTING GUIDE	
Section 1 How To Use This Book	H-1
Section 2 Basic Knowledge Required	H-3
A. Electrical Circuits	H-3
B. Use of Digital Volt-Ohm Meter	H-3
C. Important Information	H-4
D. Explanation of Abbreviations/Terms	H-5
E. General Diagnostic Information	H-9
Section 3 Testing The DDEC III/IV System	H-11
A. Tools Needed to Diagnose the System	H-11
B. Differences Between DDEC III/IV and DDEC II	H-11
C. Reading the Diagnostic Codes	H-12
D. Clearing Codes	H-14
E. Connector Checkout	H-14
F. Digital Input/Output Functions	H-14

*Supersedes TM 9-2320-360-20-3 dated 01 September 1997

TABLE OF CONTENTS - Cont'd

	Page
Section 4 Troubleshooting Charts	H-15
A. The Diagnostic Procedure - Where to Start	H-15
B. DDEC III/IV Diagnostic Codes/What They Mean	H-15
C. Beginning Charts	H-25
START - First Chart for Diagnosis of DDEC-III/IV Using DDR	H-25
CEL - First Chart for Diagnosis of DDEC-III/IV When No DDR is Available	H-35
D. Troubleshooting Charts	H-40
Chart 1 - Intermittent Code or a Symptom and No Codes	H-40
Chart 2 - Engine Cranks But Will Not Start	H-43
Chart 3 - Erratic Performance and No Codes	H-63
Chart 4 - No "Check Engine" Light During Bulb Check or Cannot Clear Codes	H-65
Chart 5 - "Check Engine" Light On and No Active Code on DDR	H-71
Chart 6 - "Check Gauges" Light On and No Active Code on DDR	H-75
Chart 7 - No Data to DDR	H-79
Chart 8 - No "Check Gauges" Light (CGL) During Bulb Check	H-85
Chart 9 - Diagnostic Request Switch Inoperative	H-91
Chart 10 - Variable Speed Governor (VSG or PTO High Idle) Inoperative	H-95
E. Diagnostics Code Charts	H-103
Flash SAE	
Codes: Codes: (Cross Reference on page vi)	
11 P187 4 - Power Take Off Input Failed Low (Voltage Low)	
(Also Called Variable Speed Governor - VSG)	H-103
12 P187 3 - Power Take Off (PTO) Input Failed High (High Voltage)	
(Also Called Variable Speed Governor - VSG)	H-111
13 P111 4 - Coolant Level Circuit Failed Low (Low Voltage)	H-117
14 P110 3 - Coolant Temperature Circuit Failed High (Voltage High)	
OR: P175 3 - Oil Temperature Circuit Failed High (Voltage High)	H-121
15 P110 4 - Coolant Temperature Circuit Failed Low (Low Voltage)	
OR: P175 4 - Oil Temperature Circuit Failed Low (Low Voltage)	H-127
16 P111 3 - Coolant Level Circuit Failed High (Voltage High)	H-133
21 P91 3 - Electronic Foot Pedal ASM (EFPA) Circuit Failed High	
(Voltage High) Also Called Throttle Position Sensor (TPS)	H-139
22 P91 4 - Electronic Foot Pedal ASM (EFPA) Circuit Failed Low	
(Voltage Low) Also Called Throttle Position Sensor (TPS)	H-145
23 P174 3 - Fuel Temperature Circuit Failed High (High Voltage)	H-153
24 P174 4 - Fuel Temperature Circuit Failed Low (Low Voltage)	H-157
25 None - No Codes	H-161

TABLE OF CONTENTS - Cont'd

	Page																																																																																																
E. Diagnostics Code Charts (Cont'd)	H-103																																																																																																
<table style="width: 100%; border-collapse: collapse;"> <thead> <tr> <th style="width: 10%; text-align: left;">Flash Codes:</th> <th style="width: 10%; text-align: left;">SAE Codes:</th> <th style="width: 80%;"></th> <th style="width: 10%;"></th> </tr> </thead> <tbody> <tr> <td>33</td> <td>P102 3</td> <td>- Turbo Boost Pressure Circuit Failed High (High Voltage)</td> <td style="text-align: right;">H-163</td> </tr> <tr> <td>34</td> <td>P102 4</td> <td>- Turbo Boost Pressure Circuit Failed Low (Low Voltage)</td> <td style="text-align: right;">H-169</td> </tr> <tr> <td>35</td> <td>P100 3</td> <td>- Oil Pressure Circuit Failed High (High Voltage)</td> <td style="text-align: right;">H-177</td> </tr> <tr> <td>36</td> <td>P100 4</td> <td>- Oil Pressure Circuit Failed Low (Low Voltage)</td> <td style="text-align: right;">H-183</td> </tr> <tr> <td>41</td> <td>S21 0</td> <td>- Too Many SRS (Missing TRS)</td> <td style="text-align: right;">H-191</td> </tr> <tr> <td>42</td> <td>S21 1</td> <td>- Too Few SRS (Missing SRS)</td> <td style="text-align: right;">H-201</td> </tr> <tr> <td>43</td> <td>P111 1</td> <td>- Coolant Level Low</td> <td style="text-align: right;">H-211</td> </tr> <tr> <td>44</td> <td>P110 0</td> <td>- Coolant Temperature High or</td> <td></td> </tr> <tr> <td></td> <td>P175 0</td> <td>- Oil Temperature High</td> <td style="text-align: right;">H-213</td> </tr> <tr> <td>45</td> <td>P100 1</td> <td>- Oil Pressure Low</td> <td style="text-align: right;">H-215</td> </tr> <tr> <td>46</td> <td>P168 1</td> <td>- Battery Voltage Low</td> <td style="text-align: right;">H-217</td> </tr> <tr> <td>52</td> <td>S254 12</td> <td>- Analog to Digital (A/D) Conversion Failure</td> <td style="text-align: right;">H-223</td> </tr> <tr> <td>53</td> <td>S253 12</td> <td>- Nonvolatile Memory Failure</td> <td style="text-align: right;">H-225</td> </tr> <tr> <td>56</td> <td>S250 12</td> <td>- J1587 Data Link Fault</td> <td style="text-align: right;">H-227</td> </tr> <tr> <td>57</td> <td>S249 12</td> <td>- J1922 Data Link Fault</td> <td style="text-align: right;">H-229</td> </tr> <tr> <td>61</td> <td>Sxxx 0</td> <td>- Injector Response Time Long</td> <td style="text-align: right;">See TM 9-2320-360-34-1</td> </tr> <tr> <td>62</td> <td>S026 3/4</td> <td>- Auxiliary Output Short to Battery,</td> <td></td> </tr> <tr> <td></td> <td></td> <td>- Auxiliary Output Open Circuit</td> <td style="text-align: right;">H-231</td> </tr> <tr> <td>63</td> <td>S057 3/4</td> <td>- PWM Short to Battery/PWM Open Circuit.</td> <td style="text-align: right;">H-233</td> </tr> <tr> <td>71</td> <td>Sxxx 1</td> <td>- Injector Response Time Short</td> <td style="text-align: right;">See TM 9-2320-360-34-1</td> </tr> <tr> <td>75</td> <td>P168 0</td> <td>- Battery Voltage High</td> <td style="text-align: right;">H-235</td> </tr> <tr> <td>76</td> <td>P121 0</td> <td>- Engine Overspeed with Engine Brake</td> <td style="text-align: right;">H-237</td> </tr> <tr> <td>85</td> <td>P121 0</td> <td>- Engine Overspeed</td> <td style="text-align: right;">H-239</td> </tr> </tbody> </table>		Flash Codes:	SAE Codes:			33	P102 3	- Turbo Boost Pressure Circuit Failed High (High Voltage)	H-163	34	P102 4	- Turbo Boost Pressure Circuit Failed Low (Low Voltage)	H-169	35	P100 3	- Oil Pressure Circuit Failed High (High Voltage)	H-177	36	P100 4	- Oil Pressure Circuit Failed Low (Low Voltage)	H-183	41	S21 0	- Too Many SRS (Missing TRS)	H-191	42	S21 1	- Too Few SRS (Missing SRS)	H-201	43	P111 1	- Coolant Level Low	H-211	44	P110 0	- Coolant Temperature High or			P175 0	- Oil Temperature High	H-213	45	P100 1	- Oil Pressure Low	H-215	46	P168 1	- Battery Voltage Low	H-217	52	S254 12	- Analog to Digital (A/D) Conversion Failure	H-223	53	S253 12	- Nonvolatile Memory Failure	H-225	56	S250 12	- J1587 Data Link Fault	H-227	57	S249 12	- J1922 Data Link Fault	H-229	61	Sxxx 0	- Injector Response Time Long	See TM 9-2320-360-34-1	62	S026 3/4	- Auxiliary Output Short to Battery,				- Auxiliary Output Open Circuit	H-231	63	S057 3/4	- PWM Short to Battery/PWM Open Circuit.	H-233	71	Sxxx 1	- Injector Response Time Short	See TM 9-2320-360-34-1	75	P168 0	- Battery Voltage High	H-235	76	P121 0	- Engine Overspeed with Engine Brake	H-237	85	P121 0	- Engine Overspeed	H-239
Flash Codes:	SAE Codes:																																																																																																
33	P102 3	- Turbo Boost Pressure Circuit Failed High (High Voltage)	H-163																																																																																														
34	P102 4	- Turbo Boost Pressure Circuit Failed Low (Low Voltage)	H-169																																																																																														
35	P100 3	- Oil Pressure Circuit Failed High (High Voltage)	H-177																																																																																														
36	P100 4	- Oil Pressure Circuit Failed Low (Low Voltage)	H-183																																																																																														
41	S21 0	- Too Many SRS (Missing TRS)	H-191																																																																																														
42	S21 1	- Too Few SRS (Missing SRS)	H-201																																																																																														
43	P111 1	- Coolant Level Low	H-211																																																																																														
44	P110 0	- Coolant Temperature High or																																																																																															
	P175 0	- Oil Temperature High	H-213																																																																																														
45	P100 1	- Oil Pressure Low	H-215																																																																																														
46	P168 1	- Battery Voltage Low	H-217																																																																																														
52	S254 12	- Analog to Digital (A/D) Conversion Failure	H-223																																																																																														
53	S253 12	- Nonvolatile Memory Failure	H-225																																																																																														
56	S250 12	- J1587 Data Link Fault	H-227																																																																																														
57	S249 12	- J1922 Data Link Fault	H-229																																																																																														
61	Sxxx 0	- Injector Response Time Long	See TM 9-2320-360-34-1																																																																																														
62	S026 3/4	- Auxiliary Output Short to Battery,																																																																																															
		- Auxiliary Output Open Circuit	H-231																																																																																														
63	S057 3/4	- PWM Short to Battery/PWM Open Circuit.	H-233																																																																																														
71	Sxxx 1	- Injector Response Time Short	See TM 9-2320-360-34-1																																																																																														
75	P168 0	- Battery Voltage High	H-235																																																																																														
76	P121 0	- Engine Overspeed with Engine Brake	H-237																																																																																														
85	P121 0	- Engine Overspeed	H-239																																																																																														
E. ENG5V - Engine Harness +5 Volts Supply	H-241																																																																																																
VEH5V - Vehicle Harness +5 Volts Supply	H-247																																																																																																
Section 5 Diagnostic Data Reader Information	H-257																																																																																																
A. Engine Data List	H-259																																																																																																
B. Diagnostic Codes	H-263																																																																																																
B.1 Active Codes	H-263																																																																																																
B.2 Inactive Codes	H-264																																																																																																
B.3 Clear Codes	H-264																																																																																																
B.4 Change Code Description	H-264																																																																																																

TABLE OF CONTENTS - Cont'd

	Page
C. View Calibration Configuration Selections	H-266
C.1 Engine Configuration	H-268
C.2 VSG Configuration	H-272
C.3 Engine Protection Configuration	H-274
C.4 ECM Input and Output Configuration	H-276
D. Fuel Injector Information	H-280
D.1 Cylinder Cutout	H-280
D.2 Response Times	H-280
D.3 View Calibration	H-283
D.4 Update Calibration	H-283
E. Switch/Light Status	H-285
F. Mid Messages Being Received	H-287

J-1587 TO FLASH CODE CROSS REFERENCE

J-1587 CODE (SID - PID/FMI)	DESCRIPTION	FLASH CODE
S001 / 0	INJECTOR RESPONSE LONG #1 CYL	61*
S002 / 0	INJECTOR RESPONSE LONG #2 CYL	61*
S003 / 0	INJECTOR RESPONSE LONG #3 CYL	61*
S004 / 0	INJECTOR RESPONSE LONG #4 CYL	61*
S005 / 0	INJECTOR RESPONSE LONG #5 CYL	61*
S006 / 0	INJECTOR RESPONSE LONG #6 CYL	61*
S007 / 0	INJECTOR RESPONSE LONG #7 CYL	61*
S008 / 0	INJECTOR RESPONSE LONG #8 CYL	61*
S001 / 1	INJECTOR RESPONSE SHORT #1 CYL	71*
S002 / 1	INJECTOR RESPONSE SHORT #2 CYL	71*
S003 / 1	INJECTOR RESPONSE SHORT #3 CYL	71*
S004 / 1	INJECTOR RESPONSE SHORT #4 CYL	71*
S005 / 1	INJECTOR RESPONSE SHORT #5 CYL	71*
S006 / 1	INJECTOR RESPONSE SHORT #6 CYL	71*
S007 / 1	INJECTOR RESPONSE SHORT #7 CYL	71*
S008 / 1	INJECTOR RESPONSE SHORT #8 CYL	71*
S021 / 0	TOO MANY SRS (MISSING TRS)	41
S021 / 1	TOO FEW SRS (MISSING SRS)	42
S026 / 3	AUXILIARY OUTPUT #1 SHORT TO BATTERY	62
S026 / 4	AUXILIARY OUTPUT #1 OPEN TO BATTERY	62
S057 / 3	PWM #1 SHORT TO BATTERY	63
S057 / 4	PWM #1 OPEN CIRCUIT	63
P091 / 3	THROTTLE SENSOR CIRCUIT HIGH VOLTAGE	21
P091 / 4	THROTTLE SENSOR CIRCUIT LOW VOLTAGE	22
P100 / 1	OIL PRESSURE LOW	45
P100 / 3	OIL PRESSURE CIRCUIT HIGH VOLTAGE	35
P100 / 4	OIL PRESSURE CIRCUIT LOW VOLTAGE	36
P102 / 3	BOOST PRESSURE CIRCUIT HIGH VOLTAGE	33
P102 / 4	BOOST PRESSURE CIRCUIT LOW VOLTAGE	34
P110 / 0	COOLANT TEMPERATURE HIGH	44
P110 / 3	COOLANT TEMP. CIRCUIT HIGH VOLTAGE	14
P110 / 4	COOLANT TEMP. CIRCUIT LOW VOLTAGE	15

* See TM 9-2320-360-34-1.

J-1587 TO FLASH CODE CROSS REFERENCE

J-1587 CODE (SID - PID/FMI)	DESCRIPTION	FLASH CODE
P111 / 1	COOLANT LEVEL LOW	43
P111 / 3	COOLANT LEVEL CIRCUIT HIGH VOLTAGE	16
P111 / 4	COOLANT LEVEL CIRCUIT LOW VOLTAGE	13
P121 / 0	ENGINE OVERSPEED WITH ENG. BRAKE	76
P168 / 0	BATTERY VOLTAGE HIGH	75
P168 / 1	BATTERY VOLTAGE LOW	46
P174 / 3	FUEL TEMP. CIRCUIT HIGH VOLTAGE	23
P174 / 4	FUEL TEMP. CIRCUIT LOW VOLTAGE	24
P175 / 0	OIL TEMPERATURE HIGH	44
P175 / 3	OIL TEMP. CIRCUIT HIGH VOLTAGE	14
P175 / 4	OIL TEMP. CIRCUIT LOW VOLTAGE	15
P187 / 3	PTO (VSG) CIRCUIT HIGH VOLTAGE	12
P187 / 4	PTO (VSG) CIRCUIT LOW VOLTAGE	11
P190 / 0	ENGINE OVERSPEED	85
S238 / 3	STOP ENGINE LIGHT SHORT TO BATTERY	32
S238 / 4	STOP ENGINE LIGHT OPEN CIRCUIT	32
S239 / 3	CHECK ENGINE LIGHT SHORT TO BATTERY	32
S239 / 4	CHECK ENGINE LIGHT OPEN CIRCUIT	32
S240 / 2	FRAM CHECKSUM INCORRECT	NONE**
S249 / 12	J1922 DATA LINK FAULT	57
S250 / 12	J1587 DATA LINK FAULT	56
S253 / 2	CALIBRATION CHECKSUM INCORRECT	NONE**
S253 / 13	INCOMPATIBLE CALIBRATION VERSION	NONE**
S253 / 12	NONVOLATILE MEMORY FAILURE	53
S254 / 0	FAILED EXTERNAL RAM	NONE**
S254 / 1	FAILED INTERNAL RAM	NONE**
S254 / 12	A/D CONVERSION FAILURE	52

** See Section 4 Troubleshooting Charts.

Section 6 HOW TO USE THIS BOOK

16. Section 2 (Basic Knowledge Required) and Section 3 (Testing the DDEC III/IV System) should be read and understood completely.
17. **If basic mechanical checks have been made, no trouble was found**, and the problem is now believed to be in the DDEC III/IV System, turn to Section 4 - Troubleshooting Charts. Always start with the first Chart (labeled START) on Page H-25. If a Diagnostic Data Reader (DDR) is not available, the chart labeled CEL (Check Engine Light) can be used.
18. Use the charts to pinpoint the problem and perform repairs. The charts are in a three-column format. The first column lists the test steps to perform and in what sequence to perform them. The second column gives the list of possible results you may obtain, based on the steps performed. The third column indicates what to do next, based on your results.

STEP/SEQUENCE	RESULT	WHAT TO DO NEXT
<div style="border: 1px solid black; padding: 2px; width: fit-content; margin-bottom: 5px;">EXAMPLE</div> <p>C2-9 Check ECM Connectors</p> <ul style="list-style-type: none"> • Turn ignition off. • Disconnect all connectors at the ECM. • Check terminals at all ECM connectors (both the ECM and harness side) for damage, corrosion, and unseated pins or sockets. 	<p>Terminals and connectors are okay. →</p> <p>Problem found. →</p>	<p>Replace ECM. Then go to C2-30.</p> <p>Repair terminals/connectors. Then go to C2-30.</p>

19. The charts will always instruct you to clear the codes after all repair work is done, and confirm the repair (typically by running the engine and checking if the codes and/or symptoms have returned).

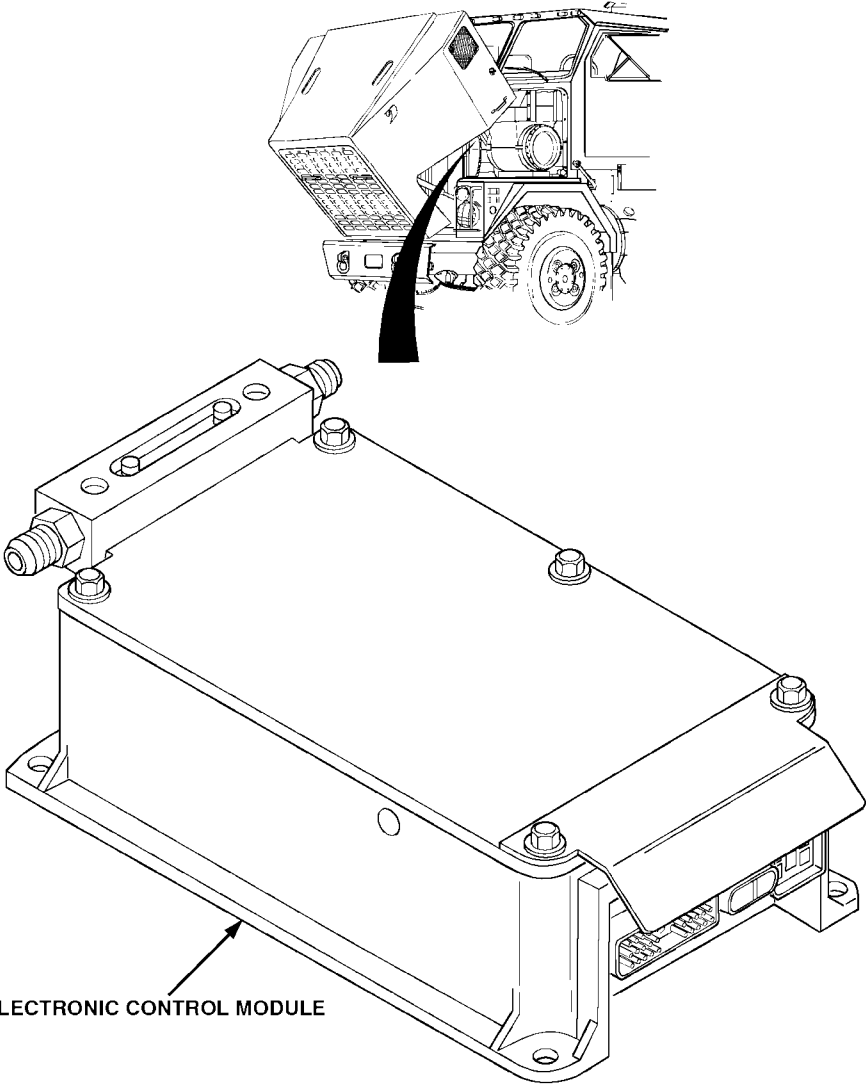

ELECTRONIC CONTROL MODULE

ECM SHOWN REMOVED FOR CLARITY

Section 7

BASIC KNOWLEDGE REQUIRED

Before using this manual, there are some areas that you should be familiar. With this basic knowledge, you will have success using the diagnostic charts.

A. ELECTRICAL CIRCUITS

- You should understand the theory of electricity and know the meaning of voltage and ohms. You should understand what happens in a circuit with an open or shorted wire. You should be able to read and understand a wiring diagram.
- You should be able to use jumper wires to make circuit checks.

B. USE OF DIGITAL VOLT-OHM METER

- You should be familiar with the digital volt-ohm meter. You should be able to measure voltage and resistance. You should be familiar with the controls of the meter and how to use it correctly.

Instructions for use of a typical digital volt-ohm meter are as follows:

Resistance Measurements

1. Connect the red test lead to the V- Ω (Volt-Ohm) input connector and the black lead to the com input connector on the meter.
2. Set the function/range switch to the desired Ω position. If the magnitude of the resistance is not known, set the switch to the highest range, then reduce until a satisfactory reading is obtained.
3. If the resistance being measured is connected to a circuit, turn off the power to the circuit being tested (turn off ignition).
4. Connect the test leads to the circuit being measured. When measuring high resistance, be careful not to contact adjacent points, even if they are insulated. Some insulators have a relatively low insulation resistance which can affect the resulting measurement.
5. Read the resistance value on the digital display.

Continuity Checks

In addition to measuring the specific resistance value of a circuit, some meters will also tell if a continuous electrical path exists. If a path exists, the circuit is said to have "continuity." (This continuity check can be used in any section of the DDEC III/IV Troubleshooting Guide where the test is looking for greater than, less than, or equal to 5 ohms.) An open circuit (broken electrical path) would have ∞ resistance and would not have continuity. To utilize this continuity feature of certain meters:

1. Place the function/range switch in any Ω range.
2. Connect the red lead to the V- Ω connector and the black lead to the com connector on the meter. With the test leads separated or measuring an out-of-range resistance, the digital display will indicate "OL" (overlimit; some meters show "1 +", " \uparrow ", or simply "1").

Section 7

BASIC KNOWLEDGE REQUIRED (Cont'd)

3. Put one test probe at one end of the wire or circuit to be tested. Use the other test lead to trace the circuit. When continuity is established, an Ω symbol will appear in the upper left corner of the digital display. If contact in the wire is maintained long enough (about 1/4 of a second), the OL will disappear and the resistance value of the wire or circuit will appear next to the symbol.
4. If your VOM does not work in the manner described above, you must know how your VOM operates in order to use this troubleshooting guide.

Voltage Measurements

1. Connect the red test lead to the V- Ω input connector and the black lead to the com input on the meter. If a DC-AC switch is present, make sure it is switched to the DC position.
2. Set the function range switch to the desired volts position. If the magnitude of the voltage is not known, set the switch to a range which will be able to read most voltages seen on a vehicle. (Typical, a 20V range will do.) Then reduce the range until a satisfactory reading is obtained.
3. Connect the test leads to the circuit being measured. In the DDEC III/IV diagnostic procedures, voltage measurements are always given as being taken at pins, sockets, Battery +, or ground. Following the voltage measurement point, the color test lead to be used is given in parenthesis (red is the V- Ω connection, an black is the com connection). Example: If the procedure says, "Take voltage reading at socket C2 (red lead) to socket K1 (black lead)", the hook-up would be as follows:

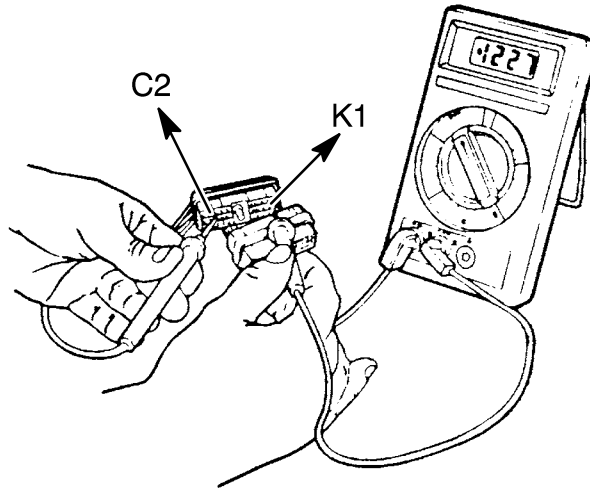

C. IMPORTANT INFORMATION

The following items must be read and thoroughly understood before using this manual.

1. The engine and ignition should always be off before the harness connectors are disconnected or reconnected.
2. When disconnecting harness connectors, be sure that the pulling force is applied to the connectors themselves and not the wires extending from them.
3. After harness connectors are reconnected to the DDEC III/IV system, the codes logged should be ignored and cleared.
4. In most all areas of Repair/Troubleshooting, a diagnostic data reader will be required.

Section 7

BASIC KNOWLEDGE REQUIRED (Cont'd)

D. EXPLANATION OF ABBREVIATIONS/TERMS

- A/D - Analog to Digital: The computer inside the ECM uses an A/D converter to convert a sensor voltage into a number which the computer can work with.
- BAT - Battery
- BOI - Beginning of Injection: The number of crank angle degrees, Before Top Dead Center, where the ECM is requesting the injectors be turned on.
- CAN - Controller Area Network: J1939 High speed control data link.
- CEL - Check Engine Light: Typically mounted on the instrument panel. It has two functions:
3. It is used as a warning lamp to tell the operator of the vehicle that a fault has occurred and the unit should be taken in for service as soon as possible.
 4. It is used by the operator or technician to "flash" out inactive trouble codes to help diagnose a problem.
- As a light bulb check and system check, the check engine light will come on for about 5 seconds when the ignition is turned on. If the CEL remains on, or comes back on, the self diagnostic system has detected a problem. If the problem goes away, the light will go out, but a trouble code will be stored in the ECM as an inactive code. (See general diagnostic information, section 2E for details.)
- CGL - Check Gauges Light: Typically mounted on the instrument panel. It has two functions:
1. It is used as a warning to the operator that a potential engine damaging condition has been detected.
 2. It is used by the operator or technician to "flash" out active trouble codes.
- As a light bulb check and system check, the stop engine light will come on for about 5 seconds when the ignition is turned on.
- CKT - Circuit
- CLS - Coolant Level Sensor: Monitors coolant level at the radiator top tank or heat exchanger.
- CP - Crankshaft Position: An ECM output generated anytime an SRS signal occurs.
- COM - Common
- CTS - Coolant Temperature Sensor: Monitors coolant temperature.
- DDEC III - Third generation Detroit Diesel Electronic Controls.
- DDEC IV - Fourth generation Detroit Diesel Electronic Controls.
- DDL - Diagnostic Data Link: The lines (wires) over which the ECM transmits information which can be read by a Diagnostic Data Reader.
- DDL+ - Data Link, Positive side: J1587 data link.
- DDL- - Data Link, Negative side: J1587 data link.

Section 7
BASIC KNOWLEDGE REQUIRED (Cont'd)

- DDR - Diagnostic Data Reader: The hand held tool used for troubleshooting the DDEC system. MPSI PRO-LINK 9000.
- ECM - Engine Control Module: The controller of the DDEC III system. It reads the engine and vehicle inputs, sensors and switches, calculates injector firing time and duration, and fires injectors at appropriate times.
- EERPOM - Electrically Erasable Programmable Read Only Memory
- PWM - Pulsewidth Modulated: Modulated signal provided by the DDEC system.
- EFPA - Electronic Foot Pedal Assembly: Contains the Throttle Position Sensor.
- EUI - Electronic Unit Injector
- FTS - Fuel Temperature Sensor: Monitors fuel temperature.
- GND - Ground
- INJ - Injector (fuel)
- LSG - Limiting Speed Governor
- N/A - Not Applicable
- OPS - Oil Pressure Sensor: Monitors oil pressure.
- OTS - Oil Temperature Sensor: Monitors oil temperature.
- PW - Pulsewidth

Section 7
BASIC KNOWLEDGE REQUIRED (Cont'd)

- SRS - Synchronous Reference Sensor: Detects when the first cylinder in the firing order is about to be fired.
- TBS - Turbocharged Boost Sensor: Monitors Turbo boost.
- TBD - To be determined.
- TD - Tachometer Driver: An output from the ECM for electronic tachometers and/or data loggers.
- TPS - Throttle Position Sensor: Used to detect throttle request (a component of the EFPA). Also referred to as LSG.
- TRS - Timing Reference Sensor: Used to detect whenever any cylinder is about to be fired.
- VIN - Vehicle Identification Number
- VSG - Variable Speed Governor. Also referred to as PTO (Power take off).
- VSS - Vehicle Speed Sensor: Used to detect vehicle speed.

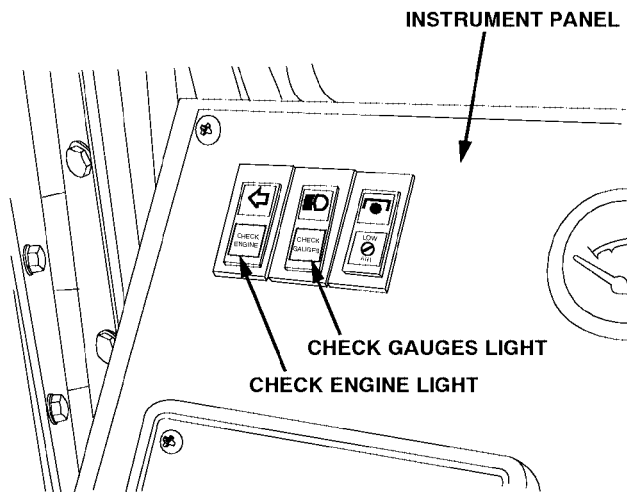

Section 7

BASIC KNOWLEDGE REQUIRED (Cont'd)

E. GENERAL DIAGNOSTIC INFORMATION

As a bulb and system check, the "Check Engine" and "Check Gauges" lights will come on for 5 seconds when the ignition switch is first turned on.

If the "Check Engine" light comes on during vehicle operation, this indicates the self diagnostic system has detected a fault.

When the diagnostic request switch is held, the diagnostic system will flash the orange lights located on the vehicle's dash. The light will be flashing the code(s) indicating the problem area(s). If the "Check Gauges" light comes on during vehicle operation, this indicates the DDEC System has detected a potential engine damaging condition. The engine should be shutdown immediately and have the engine checked for the problem.

*Active codes will be flashed on the "check gauges" light in order from most recent to least recent occurrence based on engine hours. If there are no active codes, a code 25 will be flashed.

*Inactive codes will be flashed on the "check engine" light in order from most recent to least recent occurrence based on engine hours. If there are no inactive codes, a code 25 will be flashed.

* FLASHING CODES SHOULD BE DONE WITH THE ENGINE NOT RUNNING AND IGNITION ON. *

A diagnostic code indicates a problem in a given circuit (i.e., diagnostic Code 14 indicates a problem in the oil or coolant temperature sensor circuit. This includes the oil or coolant temperature sensor, connector, harness, and Electronic Control Module (ECM). The procedure for finding the problem can be found in Diagnosis Chart Code 14. Similar charts are provided for each code. Remember, diagnosis should always begin at the starting chart (START). For an oil or coolant temperature sensor problem, it will quickly lead you to Chart 14 - but first it gets you to verify the code/symptom.

Since the self-diagnostics do not detect all possible faults, the absence of a code does not mean there are not problems in the system. If a DDEC III/IV problem is suspected, even in the absence of a code, go to START anyway. This chart can lead you to other charts which can aid in the troubleshooting process - where DDEC III/IV problems may occur but do not generate a code. **Basic mechanical checks, however, are not covered in this guide, refer to Chapter 2, Vehicle Troubleshooting.**

Section 8

TESTING THE DDEC III/IV SYSTEM

A. TOOLS NEEDED TO DIAGNOSE THE SYSTEM

The following tools and equipment are required to properly diagnose a complete system:

- MPSI - PROLINK Diagnostic Data Reader (DDR) - J38500-750 (cartridge only) (DDEC II/III only).
- Multi - protocol cartridge P/N 208040 and Smart Card P/N 802015 (DDEC III/IV only).
- Duetsch 6-pin DDR Adapter - J38500-60A
- Voltmeter and Ohmmeter: Use a digital volt-ohmmeter J-34029 or equivalent to measure voltage and resistance where required. A digital volt-ohmmeter must be used when specified in a procedure.
- Test Light 6V: Must be used when specified in the procedure.
- Jumper Wires: To bypass a circuit and to insert between special connectors. This will permit access to the connector terminals for circuit checking.
- TRS/SRS Alignment Tool: J-39815.
- .020" Feeler Gauge
- Crankshaft Position Timing Tool: J34930-A

B. DIFFERENCES BETWEEN DDEC III/IV AND DDEC II

To those thoroughly familiar with DDEC II, an outline is given of the differences in DDEC III/IV. From an installation and testing viewpoint, these differences are:

- DDEC fault codes are still able to be "flashed", but with DDEC III/IV, a diagnostic request switch has been installed. There are no longer provisions to use a jumper wire. The DDC assigned fault codes no longer appear on the "MPSI" diagnostic data reader.
- When using the MPSI DDR, the diagnostic codes are now displayed in a SAE J1587 format. The SAE have developed a standardized list of Parameter Identification Descriptions (PID), and a System Identification Description (SID). These PIDs and SID will define the area where the fault has occurred. Following the PID or SID will be a Failure Mode Identifier (FMI). The diagnostic codes (both DDEC and SAE) and their description can be found in Section 4 of this Troubleshooting Guide.
- Fault codes are now referred to as active and inactive.
- DDEC III/IV requires injector calibrations to be entered into the EEPROM with the DDR. DDEC III/IV uses this information to provide proper cylinder balancing. Injector information must be programmed whenever an injector is replaced, or changed for different cylinder location.
- DDEC III/IV engines are equipped with a 36 tooth pulse wheel, instead of DDEC II's 13 tooth pulse wheel.
- Added information now appears for some fault codes. This data includes: the hour the code is first logged, last logged, number of occurrences, number of overrides (if applicable), and the value that caused the fault to be logged (if applicable). Refer to code 85 page H-239 for details.

Section 8

TESTING THE DDEC III/IV SYSTEM (Cont'd)

C. READING THE DIAGNOSTIC CODES

NOTE: If you have turned here to begin diagnosis of a problem and already know how to read codes, as well as understand active and inactive codes, turn to the first chart (labeled START) on page H-25.

1. Active vs. Inactive Codes:

DDEC III/IV makes use of both types of codes. As their names imply, the difference between the two are as follows:

- a. Active Codes - These are the codes which are currently keeping the "Check Engine or Check Gauges" light on. Active codes are flashed via the Check Gauges Light.
- b. Inactive Codes - These are all the codes logged in the ECM (whether or not they are currently turning on the "Check Gauges or Check Engine" light). These codes can be cleared by using the Diagnostic Data Reader. Inactive codes are flashed via the Check Engine Light.

2. Using the Diagnostic Request Switch - Flash Method

This Troubleshooting Guide is intended to be used with a Diagnostic Data Reader (DDR). In most instances, only the DDR can provide the information necessary for a quick diagnosis of the problem. Should you just need to read out codes, however, and not have a DDR available, the following procedure will let you read out codes on the CEL and CGL:

- a. Turn ignition on.
- b. Depress and hold the diagnostic request switch.

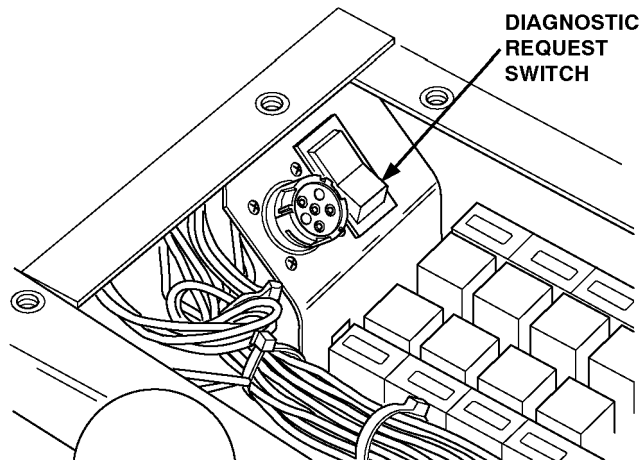
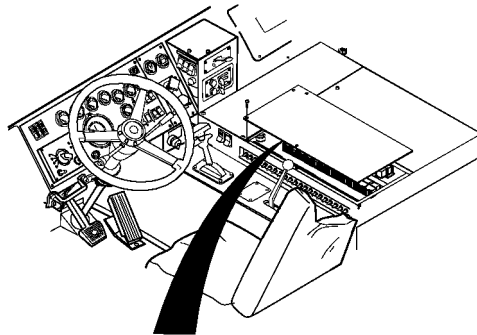

Section 8 TESTING THE DDEC III/IV SYSTEM (Cont'd)

c. Observe the codes flashing out on the CEL and CGL. Example: Code 13 (active) and 21 (inactive) below.

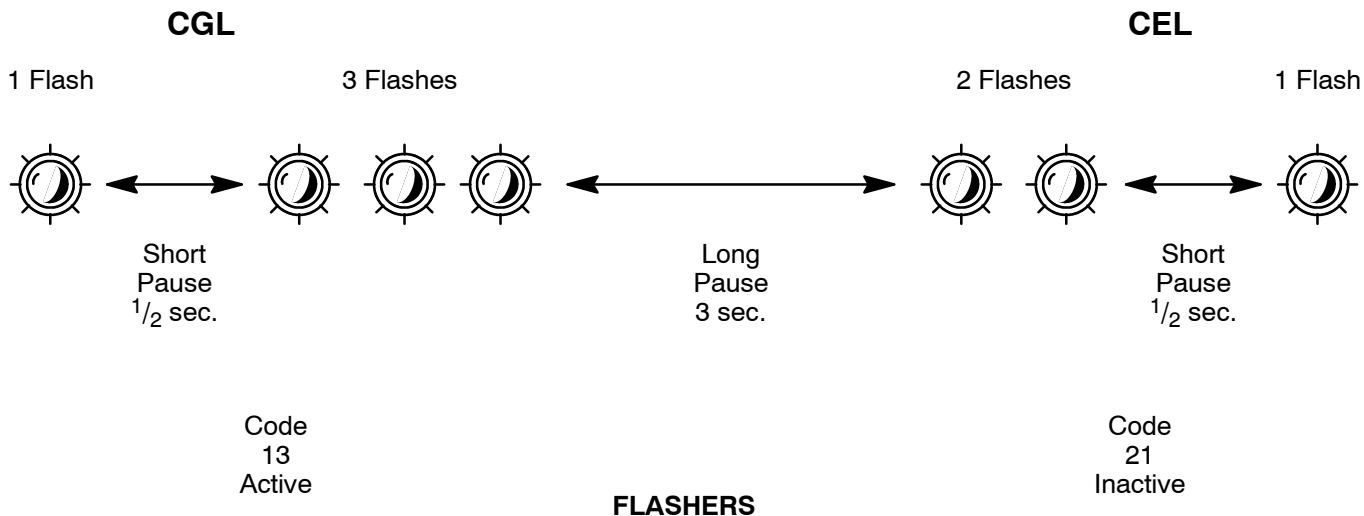

This will continue as long as the diagnostic request switch is held with the ignition on.

3. Using the Diagnostic Data Reader (DDR) or PRO-LINK 9000.

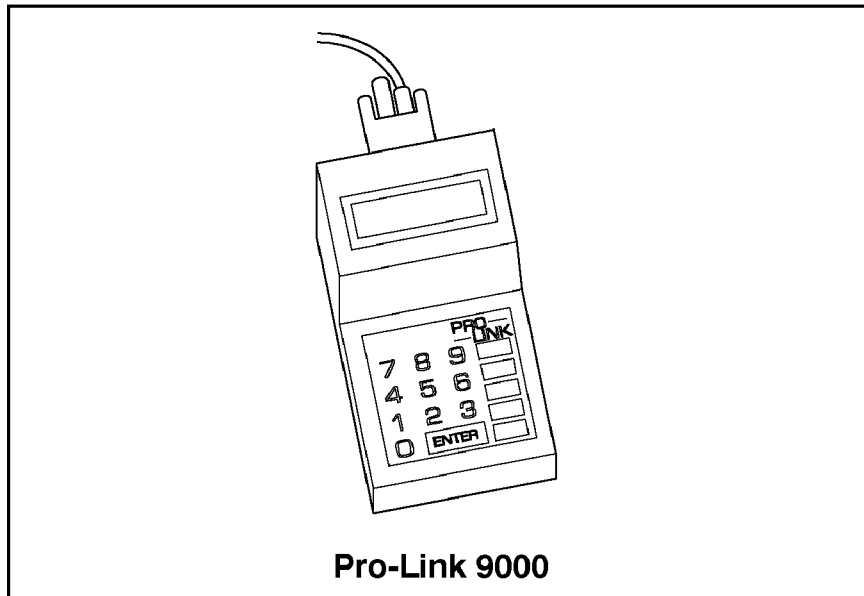

Proper use of this reader is described in the instruction manual supplied. This device is infinitely more useful in reading fault codes and diagnosing engine electronic faults than the flash code process. Section 5 of this manual provides the information obtainable with the reader.

Section 8

TESTING THE DDEC III/IV SYSTEM (Cont'd)

D. CLEARING CODES

This can only be done using the Diagnostic Data Reader (DDR). Refer to the DDR Instruction Manual for details.

Note that removing the battery cables will not clear codes.

E. CONNECTOR CHECKOUT

All system connections are environmentally protected. These connectors protect the terminations from the harsh corrosive engine compartment environment. This is important since most system signals are low voltage and corrosion could make them inoperative.

Before repairing or replacing any system component (i.e., harness, sensor, ECM, etc.) as indicated by the diagnostic charts, you should:

1. Disconnect the appropriate connector(s) associated with the suspected defective component and check for bent, broken, or dirty terminals or mating tabs. Clean, straighten, or replace as required.
2. If a problem was found, reconnect all connectors previously disconnected. Then recheck the system to see if the problem has been corrected.

NOTE: Don't probe the back of a connector or pierce the DDEC III/IV wiring for purposes of taking measurement. This can cause intermittent faults or system failures and may affect the engine warranty.

F. DIGITAL INPUT/OUTPUT FUNCTIONS

DIGITAL OUTPUTS

DDEC III/IV provides three discrete output pins on the vehicle harness which may be customized to the customer application. These outputs provide a ground (less than 0.8 volts with respect to DDEC ground) capable of sinking up to 1 ampere of DC current when the output is active.

The function may be selected by its "function number" found in the list below. No function should be assigned to more than one pin (except FUNCTION #0 - No Function).

Examples:

1. Pin J3 of the ECM's 30-pin vehicle harness connector has the transmission modulator function assigned to it. This function causes the DDEC ECM to provide a ground to activate the transmission modulator relay (R30) whenever the transmission modulator should be activated. This function turns on whenever the TPS value exceeds 80%, and turns off when the TPS value drops below 60%.
2. Pin A1 of the ECM's 30-pin vehicle harness connector has the engine brake function assigned to it. This function causes the DDEC ECM to provide a ground to activate the engine brake relay (R15) under those conditions when the engine brakes can be used. This function occurs under no-fuel conditions (TPS value = 0%) and when the engine speed is greater than 1000 RPM.

Section 9 TROUBLESHOOTING CHARTS

A. THE DIAGNOSTIC PROCEDURE - WHERE TO START

When diagnosing the cause for engine performance, fuel economy or exhaust system complaints, perform Vehicle Troubleshooting (Chapter 2) before considering DDEC as the possible source of the problem.

When diagnosing the system, always start with the first chart (labeled "START") on page H-25. This will ultimately lead to other diagnostic charts, even in the cases where no fault codes were logged but a symptom(s) was noted. In fact, if no faults were recorded (but a symptom remains), the "START" chart will refer you to "Diagnosis by Symptom", Chart 1, on page H-40, which can identify fault trees to use based on the customer complaint.

NOTICE: Although there are many charts connected with diagnostics, only one is needed to determine that the system is operating properly. Normally, only two charts are necessary to find a problem.

B. DDEC III/IV DIAGNOSTIC CODES/WHAT THEY MEAN

The following pages give a brief description of each diagnostic code. Basic facts about these codes are given below:

- Most problems must occur for a total of at least two (2) seconds before the "Check Engine" light comes on and a code is stored.
- If a problem goes away, the "Check Engine" light will turn off. But the code will remain stored in the ECM.
- Code 25 means no codes were stored at all.

FLASH CODE: 11
 DDR DISPLAY: PTO SENSOR INPUT VOLTAGE LOW
 SAE J1587 CODE: PID: 187 FMI: 4

Indicates that the PTO input to the ECM has dropped below 5% (normally < 0.25 volts) of the sensor supply voltage. This diagnostic condition is typically:

- (1) open sensor signal circuit
- (2) open sensor +5 volt supply circuit
- (3) sensor signal is shorted to the sensor return circuit or to ground
- (4) sensor +5 volt supply is shorted to sensor return circuit or to ground

FLASH CODE: 12
 DDR DISPLAY: PTO SENSOR INPUT VOLTAGE HIGH
 SAE J1587 CODE: PID: 187 FMI: 3

Indicates that the PTO input to the ECM has exceeded 95% (normally > 4.75 volts) of the sensor supply voltage. This diagnostic condition is typically:

- (1) open sensor return circuit
- (2) sensor signal circuit is shorted to the sensor +5 volt supply

Section 4

TROUBLESHOOTING CHARTS

FLASH CODE: 13
 DDR DISPLAY: COOLANT LEVEL SENSOR INPUT VOLTAGE LOW
 SAE J1587 CODE: PID: 111 FMI: 4

Indicates that the Coolant Level Sensor (CLS) input to the ECM has dropped below 5% (normally < 0.25 volts) of the sensor supply voltage. This diagnostic condition is typically:

- (1) sensor signal is shorted to the sensor return circuit or to ground
- (2) sensor +5 volt supply is shorted to sensor return circuit or to ground

The DDEC III/IV ECM supplies a switched ground to the AUXILIARY OUTPUT #8 circuit to turn **ON** the function assigned.

FLASH CODE: 14
 DDR DISPLAY: COOLANT TEMP SENSOR INPUT VOLTAGE HIGH
 SAE J1587 CODE: PID: 110 FMI: 3

Indicates that the engine Coolant Temperature Sensor (CTS) input to the ECM has exceeded 95% (normally 4.75 volts) of the sensor supply voltage. NOTE: This code will only be logged during warm engine operation. This diagnostic condition is typically:

- (1) open sensor signal circuit
- (2) open sensor return circuit
- (3) sensor signal circuit is shorted to the sensor +5 volt supply

FLASH CODE: 14
 DDR DISPLAY: OIL TEMP SENSOR INPUT VOLTAGE HIGH
 SAE J1587 CODE: PID: 175 FMI: 3

Indicates that the engine Oil Temperature Sensor (OTS) input to the ECM has exceeded 95% (normally > 4.75 volts) of the sensor supply voltage. NOTE: This code will only be logged during warm engine operation. This diagnostic condition is typically:

- (1) open sensor signal circuit
- (2) open sensor return circuit
- (3) sensor signal circuit is shorted to the sensor +5 volt supply

FLASH CODE: 15
 DDR DISPLAY: COOLANT TEMP SENSOR INPUT VOLTAGE LOW
 SAE J1587 CODE: PID: 110 FMI: 4

Indicates that the engine Coolant Temperature Sensor (CTS) input to the ECM has dropped below 5% (normally < 0.25 volts) of the sensor supply voltage. This diagnostic condition is typically:

- (1) sensor signal circuit is shorted to sensor return or to ground
- (2) sensor +5 volt supply is shorted to sensor return circuit or to ground

FLASH CODE: 15
 DDR DISPLAY: OIL TEMP SENSOR INPUT VOLTAGE LOW
 SAE J1587 CODE: PID: 175 FMI: 4

Indicates that the engine Oil Temperature Sensor (OTS) input to the ECM has dropped below 5% (normally < 0.25 volts) of the sensor supply voltage. This diagnostic condition is typically:

- (1) sensor signal circuit is shorted to sensor return or to ground
- (2) sensor +5 volt supply is shorted to sensor return circuit or to ground

Section 4

TROUBLESHOOTING CHARTS

FLASH CODE: 16
 DDR DISPLAY: COOLANT LEVEL SENSOR INPUT VOLTAGE HIGH
 SAE J1587 CODE: PID: 111 FMI: 3

Indicates that the Coolant Level Sensor (CLS) input to the ECM has exceeded 95% (normally > 4.75 volts) of the sensor supply voltage. This diagnostic condition is typically:

- (1) open sensor signal circuit
- (2) open sensor return circuit
- (3) sensor signal circuit is shorted to the sensor +5 volt supply

FLASH CODE: 21
 DDR DISPLAY: THROTTLE SENSOR INPUT VOLTAGE HIGH
 SAE J1587 CODE: PID: 91 FMI: 3

Indicates that the Throttle Position Sensor (TPS) input to the ECM has exceeded 95% (normally > 4.75 volts) of the sensor supply voltage. This diagnostic condition is typically:

- (1) open sensor return circuit
- (2) sensor signal circuit is shorted to the sensor +5 volt supply

FLASH CODE: 22
 DDR DISPLAY: THROTTLE SENSOR INPUT VOLTAGE LOW
 SAE J1587 CODE: PID: 91 FMI: 4

Indicates that the Throttle Position Sensor (TPS) input to the ECM has dropped below 5% (normally < 0.25 volts) of the sensor supply voltage. This diagnostic condition is typically:

- (1) open sensor signal circuit
- (2) open sensor +5 volt supply circuit
- (3) sensor signal is shorted to sensor return circuit or to ground
- (4) sensor +5 volt supply is shorted to the sensor return circuit or ground

FLASH CODE: 23
 DDR DISPLAY: FUEL TEMP SENSOR INPUT VOLTAGE HIGH
 SAE J1587 CODE: PID: 174 FMI: 3

Indicates that the engine Fuel Temperature Sensor (FTS) input to the ECM has exceeded 95% (normally > 4.75 volts) of the sensor supply voltage. NOTE: This code will only be logged during warm engine operation. This diagnostic condition is typically:

- (1) open sensor signal circuit
- (2) open sensor return circuit
- (3) sensor signal circuit is shorted to the sensor +5 volt supply

FLASH CODE: 24
 DDR DISPLAY: FUEL TEMP SENSOR INPUT VOLTAGE LOW
 SAE J1587 CODE: PID: 174 FMI: 4

Indicates that the engine Fuel Temperature Sensor (FTS) input to the ECM has dropped below 5% (normally < 0.25 volts) of the sensor supply voltage. This diagnostic condition is typically:

- (1) sensor signal circuit is shorted to sensor return or to ground
- (2) sensor +5 volt supply is shorted to sensor return circuit or to ground

Section 4

TROUBLESHOOTING CHARTS

FLASH CODE: 32
 DDR DISPLAY: STOP ENGINE LIGHT SHORT TO BATTERY (+)
 SAE J1587 CODE: SID: 238 FMI: 3

Indicates that the Stop Engine Light (SEL) circuit is shorted to battery (+). This diagnostic condition is detected when the DDEC III/IV ECM is unsuccessful in turning **ON** the stop engine light. This diagnostic code is typically:

- (1) failed short SEL light bulb
- (2) SEL wire in vehicle harness is shorted to battery (+)

NOTE: The DDEC III/IV ECM supplies a switched ground to the stop engine light circuit to turn **ON** the light.

FLASH CODE: 32
 DDR DISPLAY: STOP ENGINE LIGHT OPEN CIRCUIT
 SAE J1587 CODE: SID: 238 FMI: 4

Indicates that the Stop Engine Light (SEL) circuit is open or shorted to ground. This diagnostic condition is detected when the stop engine light is **OFF** and the DDEC III/IV ECM measures a low voltage on the stop engine light circuit output. This diagnostic code is typically:

- (1) failed open SEL light bulb
- (2) SEL wire in vehicle harness is open or shorted to ground

FLASH CODE: 32
 DDR DISPLAY: CHECK ENGINE LIGHT SHORT TO BATTERY (+)
 SAE J1587 CODE: SID: 239 FMI: 3

Indicates that the Check Engine Light (CEL) circuit is shorted to battery (+). This diagnostic condition is detected when the DDEC III/IV ECM is unsuccessful in turning **ON** the stop engine light. This diagnostic code is typically:

- (1) Failed short CEL light bulb
- (2) CEL wire in vehicle harness is shorted to battery (+)

NOTE: The DDEC III/IV ECM supplies a switched ground to the check engine light circuit to turn **ON** the light.

FLASH CODE: 32
 DDR DISPLAY: CHECK ENGINE LIGHT OPEN CIRCUIT
 SAE J1587 CODE: SID: 239 FMI: 4

Indicates that the Check Engine Light (CEL) circuit is open or shorted to ground. This diagnostic condition is detected when the check engine light is **OFF** and the DDEC III/IV ECM measures a low voltage on the check engine light circuit output. This diagnostic code is typically:

- (1) failed open CEL light bulb
- (2) CEL wire in vehicle is open or shorted to ground

Section 4 TROUBLESHOOTING CHARTS

FLASH CODE: 33
 DDR DISPLAY: TURBO BOOST SENSOR INPUT VOLTAGE HIGH
 SAE J1587 CODE: PID: 102 FMI: 3

Indicates that the engine Turbo Boost Sensor (TBS) input to the ECM has exceeded 85% (normally > 4.25 volts) of the sensor supply voltage. This diagnostic condition is typically:

- (1) open sensor return circuit
- (2) sensor signal circuit is shorted to the sensor +5 volt supply

FLASH CODE: 34
 DDR DISPLAY: TURBO BOOST SENSOR INPUT VOLTAGE LOW
 SAE J1587 CODE: PID: 102 FMI: 4

Indicates that the engine Turbo Boost Sensor (TBS) input to the ECM has dropped below 5% (normally < 0.25 volts) of the sensor supply voltage. This diagnostic condition is typically:

- (1) open sensor signal circuit
- (2) open sensor +5 volt supply circuit
- (3) sensor signal is shorted to the sensor return circuit or to ground
- (4) sensor +5 volt supply is shorted to sensor return circuit

FLASH CODE: 35
 DDR DISPLAY: OIL PRESSURE SENSOR INPUT VOLTAGE HIGH
 SAE J1587 CODE: PID: 100 FMI: 3

Indicates that the engine Oil Pressure Sensor (OPS) input to the ECM has exceeded 95% (normally > 4.75 volts) of the sensor supply voltage. This diagnostic condition is typically:

- (1) open sensor return circuit
- (2) sensor signal circuit is shorted to the sensor +5 volt supply

FLASH CODE: 36
 DDR DISPLAY: OIL PRESSURE SENSOR INPUT VOLTAGE LOW
 SAE J1587 CODE: PID: 100 FMI: 4

Indicates that the engine Oil Pressure Sensor (OPS) input to the ECM has dropped below 5% (normally < 0.25 volts) of the sensor supply voltage. This diagnostic condition is typically:

- (1) open sensor signal circuit
- (2) open sensor +5 volt supply circuit
- (3) sensor signal is shorted to the sensor return circuit or to ground
- (4) sensor +5 volt supply is shorted to sensor return circuit

FLASH CODE: 41
 DDR DISPLAY: TOO MANY SRS (MISSING TRS)
 SAE J1587 CODE: PID: 21 FMI: 0

Indicates that the Synchronous Reference Sensor (SRS) has detected extra pulses, or the Timing Reference Sensor (TRS) has detected missing pulses.

FLASH CODE: 42
 DDR DISPLAY: TOO FEW SRS (MISSING SRS)
 SAE J1587 CODE: PID: 21 FMI: 1

Indicates that the Synchronous Reference Sensor (SRS) has detected missing pulses, or the Timing Reference Sensor (TRS) has detected extra pulses.

Section 4 TROUBLESHOOTING CHARTS

FLASH CODE: 43
 DDR DISPLAY: COOLANT LEVEL LOW
 SAE J1587 CODE: PID: 111 FMI: 1

Indicates that the Coolant Level Sensor (CLS) has detected that the engine coolant level has dropped below the recommended safe operating range.

FLASH CODE: 44
 DDR DISPLAY: COOLANT TEMPERATURE HIGH
 SAE J1587 CODE: PID: 110 FMI: 0

Indicates that the Coolant Temperature Sensor (CTS) has detected that the engine coolant temperature has exceeded the recommended safe operating range.

FLASH CODE: 44
 DDR DISPLAY: OIL TEMPERATURE HIGH
 SAE J1587 CODE: PID: 175 FMI: 0

Indicates that the Oil Temperature Sensor (OTS) has detected that the engine oil temperature has exceeded the recommended safe operating range.

FLASH CODE: 45
 DDR DISPLAY: OIL PRESSURE LOW
 SAE J1587 CODE: PID: 100 FMI: 1

Indicates that the Oil Pressure Sensor (OPS) has detected that the engine oil pressure has dropped below the recommended safe operating range.

FLASH CODE: 46
 DDR DISPLAY: ECM BATTERY VOLTAGE LOW
 SAE J1587 CODE: PID: 168 FMI: 1

Indicates that the DDEC III/IV ECM has detected that the main battery supply voltage to the ECM has dropped below the recommended operating range.

FLASH CODE: 52
 DDR DISPLAY: ECM A/D CONVERSION FAILURE
 SAE J1587 CODE: SID: 254 FMI: 12

Indicates that the DDEC III/IV ECMs internal Analog to Digital (A/D) Converter device has malfunctioned. Intermittent diagnostic conditions of this type can be caused by faulty external electrical system.

FLASH CODE: 53
 DDR DISPLAY: NONVOLATILE MEMORY DATA INCORRECT
 SAE J1587 CODE: SID: 253 FMI: 2

Indicates that the ECM upon startup has been unable to read a valid copy of a engine data record (calibration, faults, or accumulators) stored in nonvolatile memory.

FLASH CODE: 53
 DDR DISPLAY: NONVOLATILE MEMORY FAILURE
 SAE J1587 CODE: SID: 253 FMI: 12

Indicates that the ECM was unable to update an engine data record (calibration, faults, or accumulators) stored in nonvolatile memory.

Section 4

TROUBLESHOOTING CHARTS

FLASH CODE: 56
 DDR DISPLAY: J1587 DATA LINK FAILURE
 SAE J1587 CODE: SID: 250 FMI: 12

Indicates that the J1587 (diagnostic) data link is no longer allowing the ECM to transmit data. This diagnostic condition is typically:

- (1) either or both of the data link circuits are open at some point in the network
- (2) either or both of the data link circuits are shorted to ground at some point in the network
- (3) either or both of the data link circuits are shorted to battery (+) at some point in the network
- (4) the pair of data link circuits are shorted together

FLASH CODE: 57
 DDR DISPLAY: J1922 DATA LINK FAILURE
 SAE J1587 CODE: SID: 249 FMI: 12

Indicates that the J1922 (Low Speed Powertrain) data link is no longer allowing the ECM to transmit data. This diagnostic condition is typically:

- (1) either or both of the data link circuits are open at some point in the network
- (2) either or both of the data link circuits are shorted to ground at some point in the network
- (3) either or both of the data link circuits are shorted to battery (+) at some point in the network
- (4) the pair of data link circuits are shorted together

FLASH CODE: 61
 DDR DISPLAY: XXX INJECTOR RESPONSE TIME LONG
 SAE J1587 CODE: SID: XX FMI: 0

Indicates that the time it takes from when the DDEC III/IV ECM requests an injector be turned on to when the injector solenoid valve actually closes is longer than the high limit of the expected range. This diagnostic condition is typically:

- (1) bad injector harness/connection (high resistance)
- (2) blown fuses in the ECM battery (+) voltage supply harness
- (3) sticky solenoid valve

NOTE: The injector diagnostic SID (Subsystem Identifier) indicates which cylinder number has an injector with a long response time. The injector number describes the cylinder and/or bank which has the injector with a long response time. The troubleshooting chart for this flash code is covered in TM 9-2320-360-34-1.

Injector response times generally increase with low battery supply voltage and decrease with high battery supply voltage. Although injector response times vary from injector to injector at a given RPM, each individual injector response time should remain relatively consistent from one firing to the next. Wide variations in response time (typically +/- 0.2 msec) for one injector at a steady engine RPM may indicate an electrical problem (faulty alternator or voltage regulator, poor or broken ground cables, etc.).

FLASH CODE: 62
 DDR DISPLAY: (AUXILIARY OUTPUT #1) SHORT TO BATTERY (+)
 SAE J1587 CODE: SID: 026 FMI: 3

Indicates that the function (engine brake) assigned to the Auxiliary Output #1 circuit output is shorted to battery (+). This diagnostic condition is detected when the DDEC III/IV ECM is unsuccessful in turning **ON** the configurable function.

NOTE: The DDR will display the parameter text description in TABLE 2 (ECM Output Options) to identify the function assigned to AUXILIARY OUTPUT #1.

The DDEC III/IV ECM supplies a switched ground to the AUXILIARY OUTPUT #1 circuit to turn **ON** the function assigned.

Section 4 TROUBLESHOOTING CHARTS

FLASH CODE: 62
 DDR DISPLAY: (AUXILIARY OUTPUT #1) OPEN CIRCUIT
 SAE J1587 CODE: SID: 026 FMI: 4

Indicates that the function (engine brake) assigned to the Auxiliary Output #1 circuit output is open or is shorted to ground. This diagnostic condition is detected when the Auxiliary Output #1 function is **OFF** and the DDEC III/IV ECM measures a low voltage on the circuit output.

NOTE: The DDR will display the parameter text description in TABLE 2 (ECM Output Options) to identify the function assigned to AUXILIARY OUTPUT #1.

FLASH CODE: 63
 DDR DISPLAY: PWM DRIVER #1 SHORT TO BATTERY (+)
 SAE J1587 CODE: SID: 057 FMI: 3

Indicates that the PWM DRIVER #1 circuit (transmission modulator) output is shorted to battery (+). This diagnostic condition is detected when the DDEC III/IV ECM is unsuccessful in turning ON the circuit function.

NOTE: The DDEC III/IV ECM supplies a switched ground to the PWM DRIVER #1 circuit to turn **ON** the circuit function.

FLASH CODE: 63
 DDR DISPLAY: PWM DRIVER #1 OPEN CIRCUIT
 SAE J1587 CODE: SID: 057 FMI: 4

Indicates that the PWM DRIVER #1 circuit (transmission modulator) output is open or is shorted to ground. This diagnostic condition is detected when the PWM Driver #1 function is OFF and the DDEC III/IV ECM measures a low voltage on the circuit output.

FLASH CODE: 71
 DDR DISPLAY: XXX INJECTOR RESPONSE TIME SHORT
 SAE J1587 CODE: SID: XX FMI: 1

Indicates that the time it takes from when the DDEC III/IV ECM requests an injector be turned on to when the injector solenoid valve actually closes is shorter than the lower limit of the expected range. This diagnostic condition is typically:

- (1) aerated fuel system
- (2) high system battery (+) supply voltage
- (3) failed solenoid valve

NOTE: The injector diagnostic SID (Subsystem IDentifier) indicates which cylinder number has an injector with a short response time. The injector number describes the cylinder and/or bank which has the injector with a short response time. The troubleshooting chart for this flash code is covered in TM 9-2320-360-34-1.

Injector response times generally increase with low battery supply voltage and decrease with high battery supply voltage. Although injector response times vary from injector to injector at a given RPM, each individual injector response time should remain relatively consistent from one firing to the next. Wide variations in response time (typically +/- 0.2 msec) for one injector at a steady engine RPM may indicate an electrical problem (faulty alternator or voltage regulator, poor or broken ground cables, etc.).

Section 4 TROUBLESHOOTING CHARTS

FLASH CODE: 75
 DDR DISPLAY: ECM BATTERY VOLTAGE HIGH
 SAE J1587 CODE: PID: 168 FMI: 0

Indicates that the DDEC III/IV ECM has detected that the main battery supply voltage to the ECM has exceeded the recommended operating range.

FLASH CODE: 76
 DDR DISPLAY: ENGINE OVERSPEED WITH ENGINE BRAKE
 SAE J1587 CODE: PID: 121 FMI: 0

Indicates that the engine RPM has exceeded the recommended safe operating range.

FLASH CODE: 85
 DDR DISPLAY: ENGINE OVERSPEED
 SAE J1587 CODE: PID: 190 FMI: 0

Indicates that the engine RPM has exceeded the recommended safe operating range.

FLASH CODE: --
 DDR DISPLAY: FRAM CHECKSUM INCORRECT
 SAE J1587 CODE: SID: 240 FMI: 2

Indicates that the ECM system operation software has been corrupted and is unable to operate. This diagnostic condition is typically:

The ECM system programming operation failed to run to completion. Replace ECM (para 7-29.1).

FLASH CODE: --
 DDR DISPLAY: INCOMPATIBLE CALIBRATION VERSION
 SAE J1587 CODE: SID: 253 FMI: 13

Indicates that the current ECM system operation software is not compatible with the engine calibration loaded in the ECM. This diagnostic condition is typically:

The ECM programming process was performed in the incorrect order or did not run to completion. Replace ECM (para 7-29.1).

FLASH CODE: --
 DDR DISPLAY: CALIBRATION CHECKSUM INCORRECT
 SAE J1587 CODE: SID: 253 FMI: 2

Indicates that the engine calibration loaded in the ECM has been corrupted and is unable to operate. This diagnostic condition is typically:

The engine calibration programming operation failed to run to completion. Replace ECM (para 7-29.1).

FLASH CODE: --
 DDR DISPLAY: FAILED EXTERNAL RAM
 SAE J1587 CODE: SID: 254 FMI: 0

Indicates that some or all of the memory circuitry that is external to the ECM microprocessor has failed and is unable to operate. Replace ECM (para 7-29.1).

FLASH CODE: --
 DDR DISPLAY: FAILED INTERNAL RAM
 SAE J1587 CODE: SID: 254 FMI: 1

Indicates that some or all of the memory circuitry that is internal to the ECM microprocessor has failed and is unable to operate. Replace ECM (para 7-29.1).

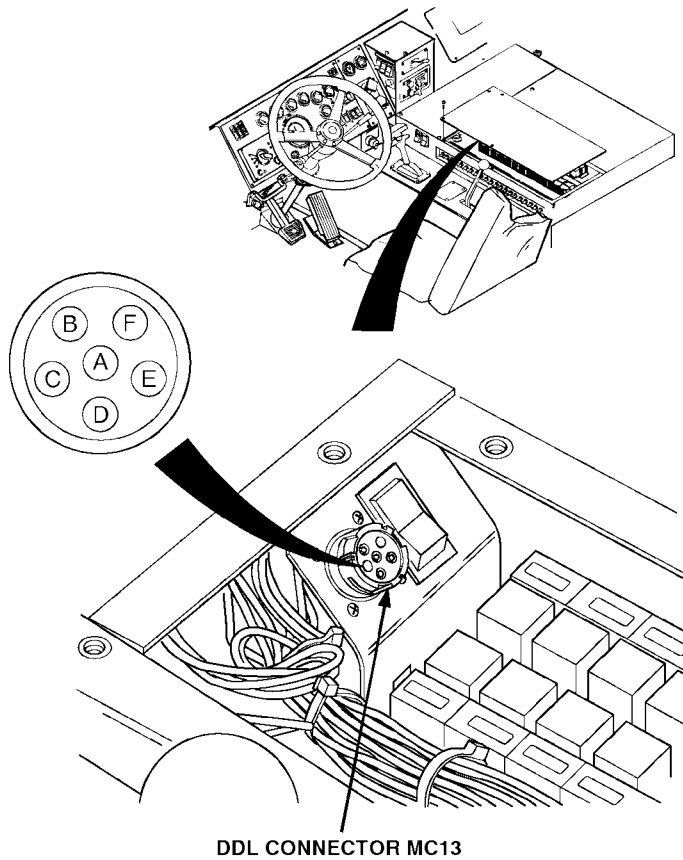
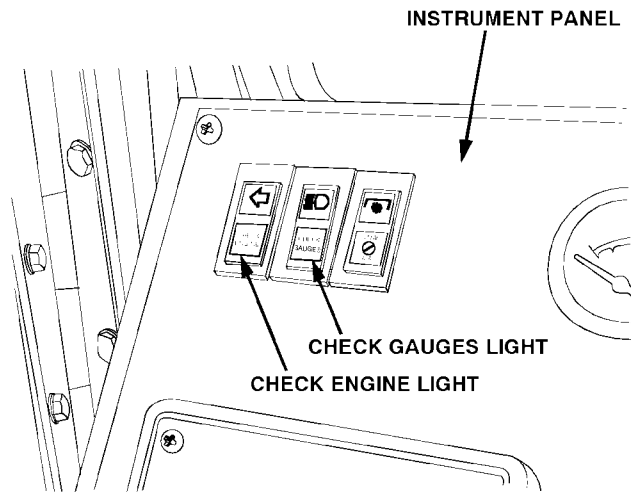

Section 4 TROUBLESHOOTING CHARTS

C. START - FIRST CHART FOR DIAGNOSIS OF DDEC-III/IV USING DDR

STEP/SEQUENCE	RESULT	WHAT TO DO NEXT
<p>START-10 Note “Check Engine/Check Gauges” Light</p> <hr/> <ul style="list-style-type: none"> • Turn ignition on while at the same time observing the “Check Engine/Check Gauges” lights (engine not running). 	<p>Light or lights comes on and stays on. →</p> <p>Lights come on for up to 5 seconds, then goes out. →</p> <p>Lights are off. →</p> <p>Erratic or intermittent light. →</p>	<p>Go to START-11.</p> <p>Go to START-12.</p> <p>Go to Chart 4, page H-65.</p> <p>Go to START-16.</p>
<p>START-11 Read Active Codes Using DDR</p> <hr/> <ul style="list-style-type: none"> • Remove eight screws and cover from electronic control box assembly. • Plug DDR into the DDL connector. • Read active codes by selecting the DIAGNOSTIC CODE MENU (ACTIVE CODES) on the DDR. 	<p>Active codes (other than “NO CODES”) on DDR. →</p> <p>No active code. →</p> <p>DDR display reads “NO DATA BEING RECEIVED FROM SYSTEM” or “DDEC SYSTEM NOT RESPONDING”. →</p> <p>DDR display is blank or random. →</p>	<p>Follow appropriate diagnostic charts for code(s) received. (See Index on page ii).</p> <p>Go to Chart 5, page H-71.</p> <p>Go to START-15.</p> <p>Go to START-18.</p>

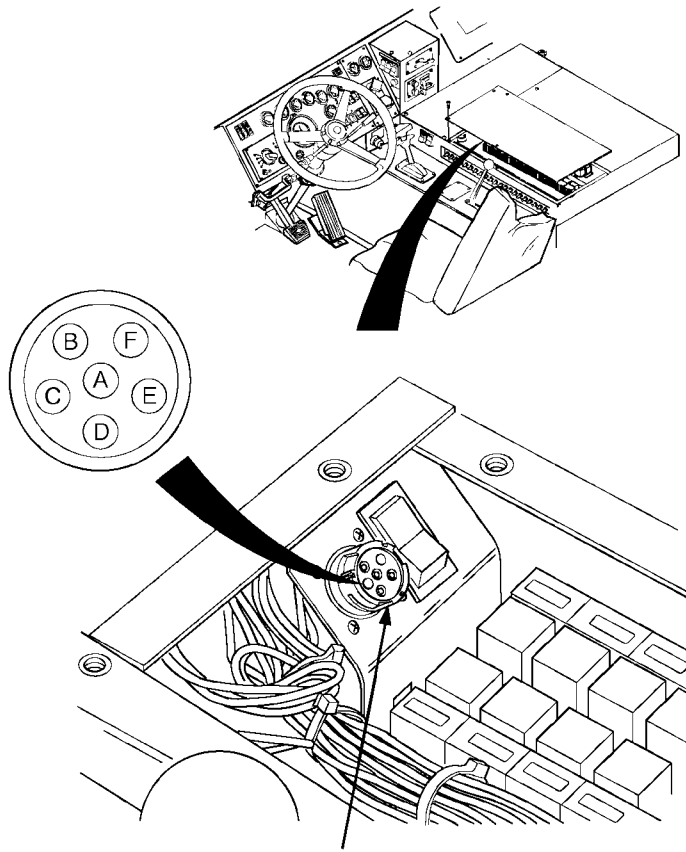

DDL CONNECTOR MC13

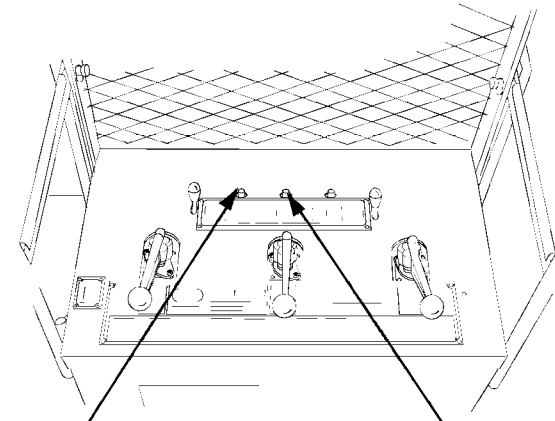
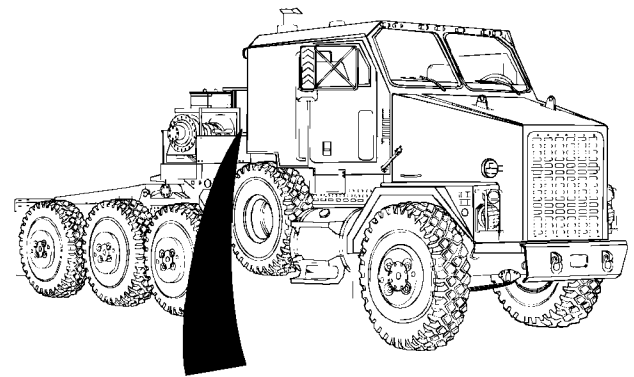

LEFT ENGINE SPEED CONTROL SWITCH

PUSH TO LOCK ENGINE @ HIGH IDLE SWITCH

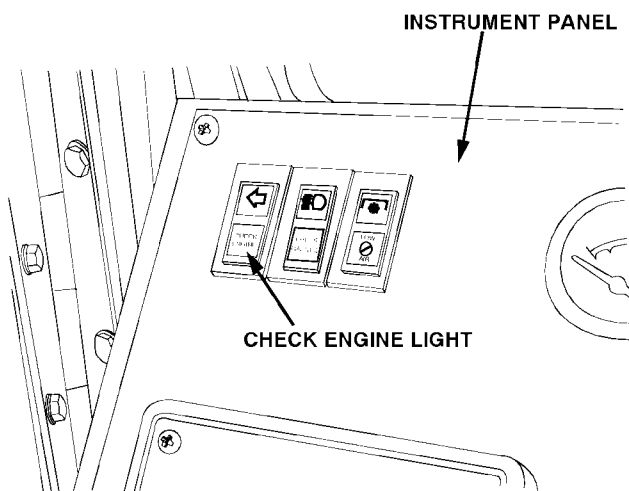

INSTRUMENT PANEL

CHECK ENGINE LIGHT

Section 4 TROUBLESHOOTING CHARTS

C. START - FIRST CHART FOR DIAGNOSIS OF DDEC-III/IV USING DDR (Cont'd)

STEP/SEQUENCE	RESULT	WHAT TO DO NEXT
<p>START-12 Read All Codes Using DDR</p> <ul style="list-style-type: none"> • Remove eight screws and cover from electronic control box assembly. • Plug DDR into DDL connector. • Read all inactive codes by selecting inactive codes on DDR. 	<p>Codes 52, 110, 175/3, 174/3, or 190/0.</p> <p>Any codes except 52, 110, 175/3, 174/3, or 190/0.</p> <p>No Codes.</p> <p>DDR display reads "NO DATA BEING RECEIVED FROM SYSTEM" or "DDEC SYSTEM NOT RESPONDING".</p> <p>DDR display is blank or random.</p>	<p>Follow appropriate diagnostic charts for code(s) received. (See Table of Contents on page ii).</p> <p>Go to START-13.</p> <p>Go to Chart 1, page H-40.</p> <p>Go to Chart 7, page H-79.</p> <p>Go to START-18.</p>
<p>START-13 Attempt to Make Codes Active</p> <p>*SEE NOTE BELOW*</p> <ul style="list-style-type: none"> • Clear codes by selecting CLEAR CODES on the DDR. • Attempt to start and run the engine (TM 9-2320-360-10). • Try to get the "Check Engine" light on by: <ul style="list-style-type: none"> -warming up the engine. -slowly changing the RPM from -idle to no load speed. • Position left ENGINE SPEED CONTROL switch to HIGH ENGINE IDLE and press PUSH TO LOCK ENGINE @ HIGH IDLE SWITCH. • Run engine for 1 minute or until "Check Engine" light comes on. 	<p>Engine will not start.</p> <p>"Check Engine" light is on.</p> <p>"Check Engine" light is off.</p> <p>"Check Engine" flashes briefly.</p>	<p>Go to Chart 2, page H-43.</p> <p>Read active codes on DDR while light is on and follow the appropriate diagnostic chart on page ii.</p> <p>Problem may be intermittent - See Chart 1, page H-40, Step C1-2.</p> <p>Go to START-5.</p>

*NOTE: If a potential engine damaging Code (i.e., 100/1) exists, monitor that parameter when running engine.

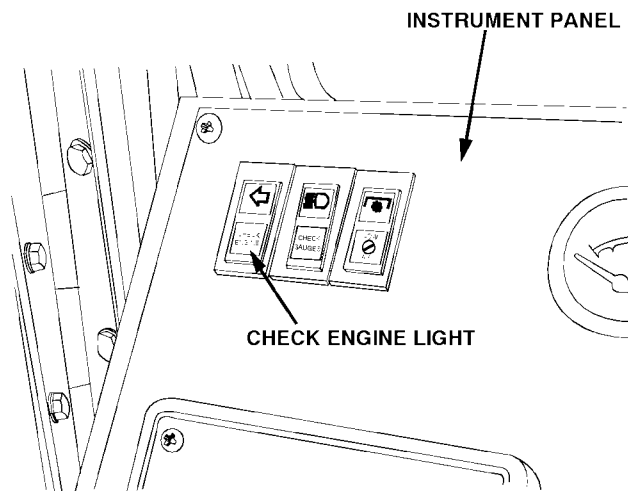
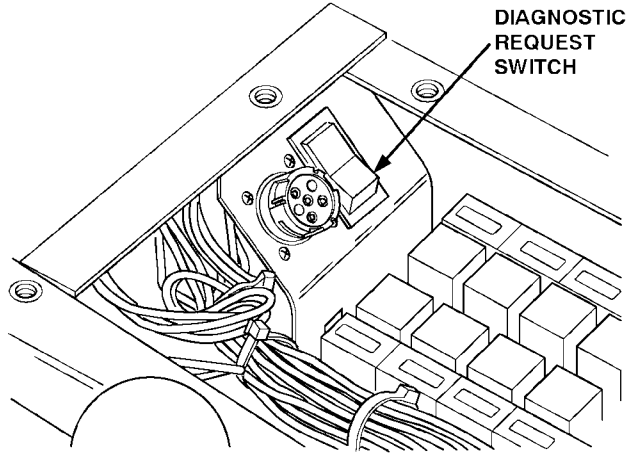

Section 4 TROUBLESHOOTING CHARTS

C. START - FIRST CHART FOR DIAGNOSIS OF DDEC-III/IV USING DDR (Cont'd)

STEP/SEQUENCE	RESULT	WHAT TO DO NEXT
<p>START-14 Read All Codes Again</p> <hr/> <ul style="list-style-type: none"> • Read inactive codes on DDR. 	<p>Any codes. →</p> <p>DDR display reads "NO DATA BEING RECEIVED FROM SYSTEM" or "DDEC SYSTEM NOT RESPONDING". →</p> <p>DDR display is blank or random. →</p>	<p>Follow appropriate diagnostic chart for codes received. (See Table of Contents on page ii).</p> <p>Go to Chart 7, page H-79.</p> <p>Go to START-18.</p>
<p>START-15 Read Codes on the "Check Engine" Light</p> <hr/> <ul style="list-style-type: none"> • Unplug the DDR. • Ignition on. Engine not running. Depress and hold diagnostic request switch. • Read codes flashing out on the "Check Engine" light. 	<p>Flashes out codes. →</p> <p>Does not flash out codes. →</p>	<p>To diagnose codes, follow appropriate diagnostic chart for codes received. (See page ii). To diagnose DDR system, go to C7-4, page H-81.</p> <p>Go to Chart 9, page H-91.</p>
<p>START-16 Intermittent "Check Engine" Light</p> <hr/> <ul style="list-style-type: none"> • Note whether flashing "Check Engine" light is reading a valid code or if it's just erratic. 	<p>Flashing a valid code. →</p> <p>Erratic or intermittent "Check Engine" light. →</p>	<p>Go to START-17.</p> <p>Go to Chart 1, page H-40.</p>

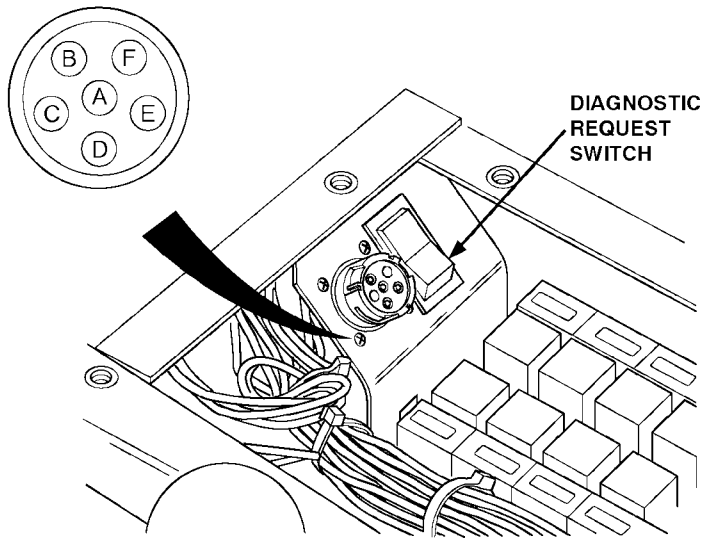

Section 4 TROUBLESHOOTING CHARTS

C. START - FIRST CHART FOR DIAGNOSIS OF DDEC-III/IV USING DDR (Cont'd)

STEP/SEQUENCE	RESULT	WHAT TO DO NEXT
<p>START-17 Check for Short</p> <hr/> <ul style="list-style-type: none"> • Plug DDR into Connector. Select SWITCH/LIGHT STATS on DDR. • Read Diagnostic Request SW. status. 	<p>ON. —————→</p> <p>OFF. —————→</p>	<p>Ckt #528 is shorted to ground. Repair short, then go to START-30.</p> <p>Go to Chart 9, page H-91.</p>
<p>START-18 Check for +12 Volts at DDR Connector</p> <hr/> <ul style="list-style-type: none"> • Turn ignition on. • Read voltage at the DDR connector, from pin "C" (red lead) to pin "E" (black lead). 	<p>Greater than or equal to 10.0 volts. —————→</p> <p>Less than 10.0 volts. —————→</p>	<p>There is a problem with either the DDR or the data link lines. Go to C7-4, page H-81. (For diagnosis of DDEC III/IV without a DDR, go to CEL-10 on page H-35.</p> <p>Either the switched +12 volt line or the ground line is open to the DDR connector. Repair open. Then go to START-30.</p>

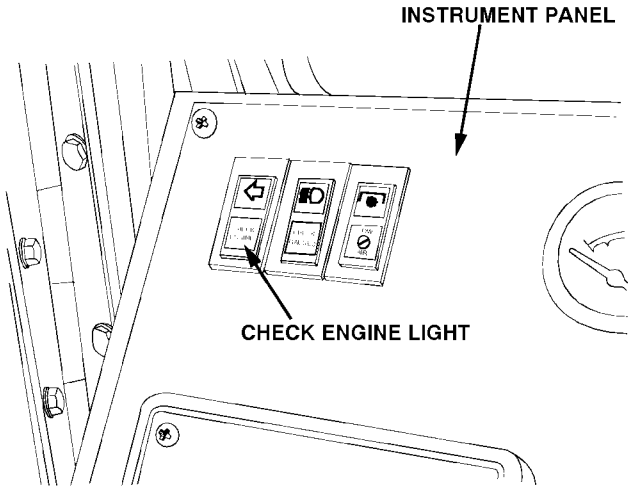

Section 4 TROUBLESHOOTING CHARTS

C. START - FIRST CHART FOR DIAGNOSIS OF DDEC-III/IV USING DDR (Cont'd)

STEP/SEQUENCE	RESULT	WHAT TO DO NEXT
<p>START-30 Verify Repairs</p> <hr/> <ul style="list-style-type: none"> • Turn ignition off. • Reconnect all connectors. • Turn ignition on. • Clear codes. • Turn ignition off. • Turn ignition on. • Observe the "Check Engine" light. 	<p>"Check Engine" light comes on for up to 5 seconds, then goes out.</p> <p>"Check Engine" light is flashing.</p> <p>"Check Engine" light comes on and stays on.</p>	<p>→ Repairs are complete.</p> <p>→ All system diagnostics are complete. Please review this section from the first step to find the error.</p> <p>→ Go to START-1, pg H-25.</p>

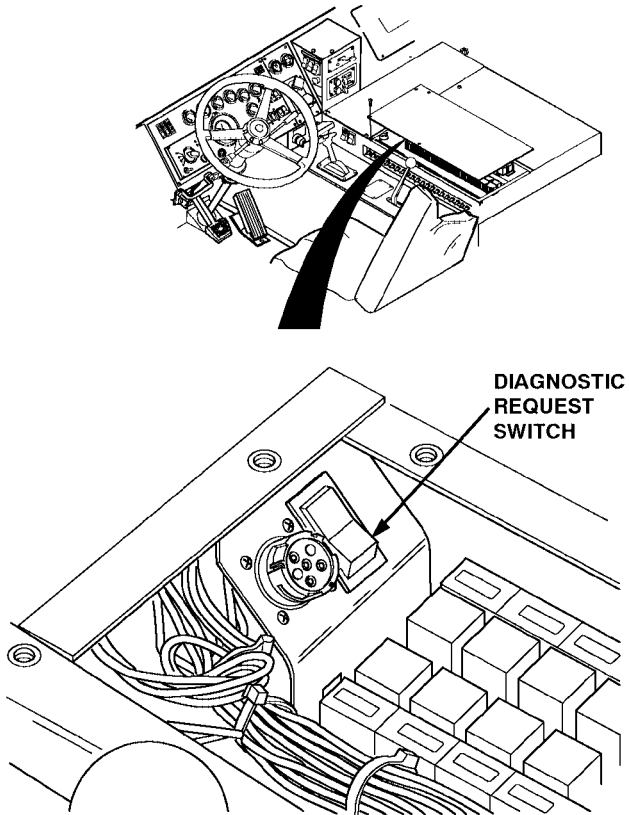
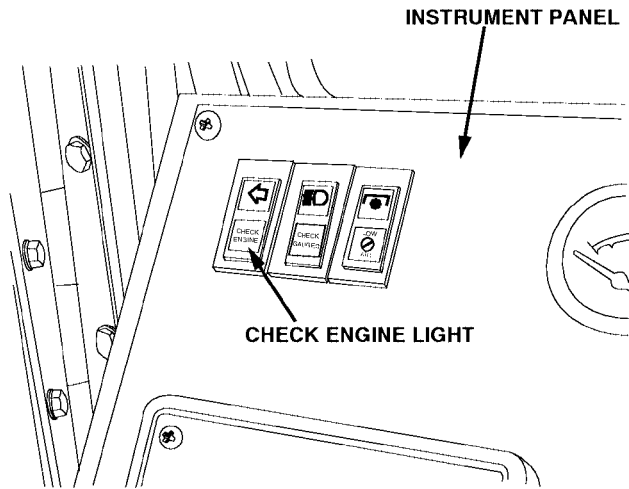

Section 4 TROUBLESHOOTING CHARTS

C. CEL - FIRST CHART FOR DIAGNOSIS OF DDEC-III/IV WHEN NO DDR IS AVAILABLE

NOTE: Although this section will help you get started, later sections of the Troubleshooting Guide may require using a DDR.

STEP/SEQUENCE	RESULT	WHAT TO DO NEXT
<p>CEL-10 Note "Check Engine" Light</p> <ul style="list-style-type: none"> • Turn ignition on while at the same time observing the "Check Engine" light. 	<p>Light comes on and stays on. →</p> <p>Light comes on for up to 5 seconds, then goes out. →</p> <p>Light is off. →</p> <p>Flashing light. →</p>	<p>Go to CEL-11.</p> <p>Go to CEL-11.</p> <p>Go to Chart 4, page H-65.</p> <p>Go to CEL-17.</p>
<p>CEL-11 Read Codes</p> <ul style="list-style-type: none"> • Turn ignition on. • Depress and hold the diagnostic request switch. 	<p>Flashes out codes. →</p> <p>"Check Engine" light is always on but doesn't flash out codes. →</p> <p>"Check Engine" light never comes on. →</p>	<p>Go to CEL-12.</p> <p>Go to Chart 6, page H-75.</p> <p>Go to CEL-15.</p>
<p>CEL-12 Follow Codes</p> <ul style="list-style-type: none"> • Note and record code(s). 	<p>Flash Codes 14, 15, 23, 44, or 85. →</p> <p>Any flash codes except 14, 15, 23, 44, or 85. →</p> <p>Flash code 25 - (No codes.) →</p>	<p>Follow appropriate diagnostic charts for the code(s) received. (See Index on page ii.)</p> <p>Go to CEL-13.</p> <p>If drive complaint persists, go to Chart 1, page H-40.</p>

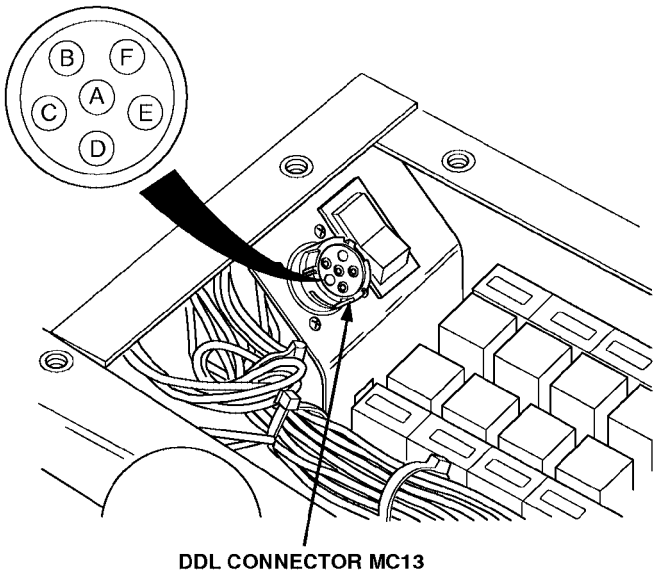

DDL CONNECTOR MC13

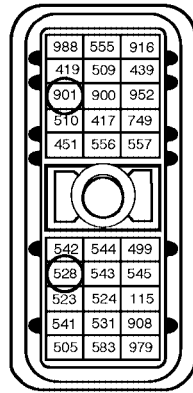

A
B
C
D
E

F
G
H
J
K

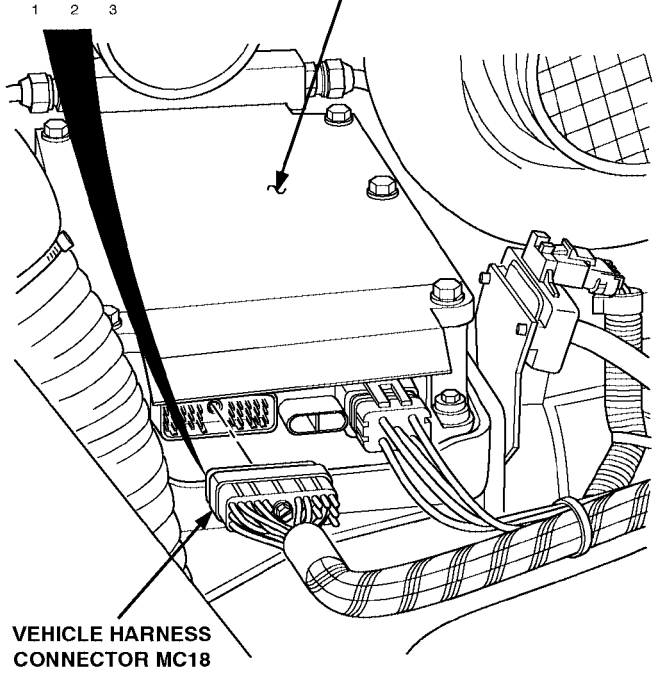

VEHICLE HARNESS CONNECTOR MC18

Section 4 TROUBLESHOOTING CHARTS

C. CEL - FIRST CHART FOR DIAGNOSIS OF DDEC-III/IV WHEN NO DDR IS AVAILABLE (Cont'd)

STEP/SEQUENCE	RESULT	WHAT TO DO NEXT
<p>CEL-13 Verify Code(s)</p> <ul style="list-style-type: none"> • Turn ignition on. • Obtain a DDR. • Clear codes. • Turn ignition off then back on. • Note status of "Check Engine" light. 	<p>"Check Engine" light stays on. →</p> <p>"Check Engine" light goes on for 5 seconds, then goes out. →</p> <p>"Check Engine" light is erratic or intermittent. →</p>	<p>Read codes and follow appropriate diagnostic chart (See pg ii).</p> <p>Go to CEL-14.</p> <p>Go to CEL-17.</p>
<p>CEL-14 Verify Code(s) with the Engine Running</p> <ul style="list-style-type: none"> • Attempt to start and run the engine (TM 9-2320-360-10). • Try to get the "Check Engine" light on by: <ul style="list-style-type: none"> - warming up the engine - slowly changing the engine from idle to no load speed. • Run engine until the "Check Engine" light comes on or for 1 minute. 	<p>Engine will not start. →</p> <p>"Check Engine" light is off. →</p> <p>"Check Engine" light is on. →</p>	<p>Go to Chart 2, pg H-43.</p> <p>Previous codes should be regarded as intermittent. Go to Chart 1, pg H-40.</p> <p>Read codes. Follow appropriate diagnostic code chart pg ii.</p>
<p>CEL-15 Check for Open</p> <ul style="list-style-type: none"> • Turn ignition off. • Disconnect the vehicle harness connector at the ECM. • Install a jumper wire between sockets C1 and G1 of the vehicle harness connector. • Also read resistance between pin E of DDL connector and a good ground. 	<p>Less than or equal to 5 ohms on either reading. →</p> <p>Greater than 5 ohms or open on either reading. →</p>	<p>Go to CEL-16.</p> <p>An open exists either in the diagnostic request line (ckt #528) or in the DDR ground line (ckt #901). Repair open. Then go to CEL-30.</p>

988	555	916
419	509	439
901	900	952
510	417	749
451	556	557
		
542	544	499
528	543	545
523	524	115
541	531	908
505	583	979

A
B
C
D
E

F
G
H
J
K

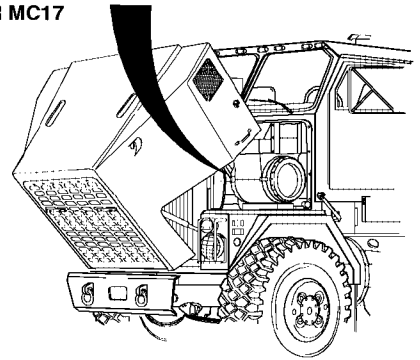
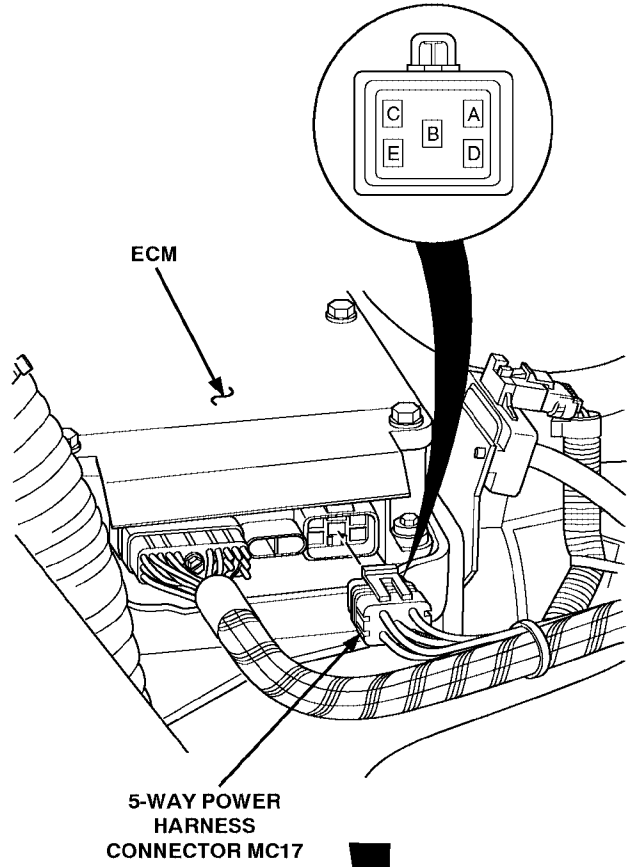
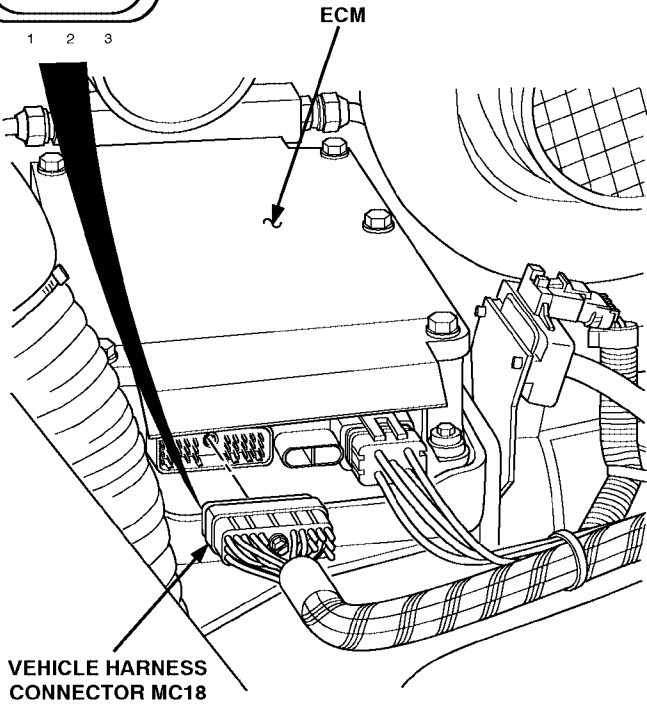

Section 4 TROUBLESHOOTING CHARTS

C. CEL - FIRST CHART FOR DIAGNOSIS OF DDEC-III/IV WHEN NO DDR IS AVAILABLE (Cont'd)

STEP/SEQUENCE	RESULT	WHAT TO DO NEXT
<p>CEL-16 Check ECM Connectors</p> <ul style="list-style-type: none"> • Disconnect the 5-way power harness connector at the ECM. • Check terminals at both the 5-way power harness connector, and vehicle harness connector (both the ECM and harness side) for damage; bent, corroded and unseated pins or sockets. 	<p>Terminals and connectors are okay. →</p> <p>Problem found. →</p>	<p>Replace ECM (para 7-29.1). Then go to CEL-30.</p> <p>Repair terminals/connectors (para 7-77). Then go to CEL-30.</p>
<p>CEL-17 Intermittent Check</p> <ul style="list-style-type: none"> • Note whether flashing "Check Engine" light is reading a valid code or if it's just erratic. 	<p>Flashing a valid code. →</p> <p>Erratic or intermittent "Check Engine" light. →</p>	<p>Go to CEL-18.</p> <p>Go to Chart 1, page H-40.</p>
<p>CEL-18 Check for Short</p> <ul style="list-style-type: none"> • Plug DDR into DDL connector. Select SWITCH/LIGHT STATS on DDR. • Read Diagnostic Request SW. status. 	<p>ON. →</p> <p>OFF. →</p>	<p>Circuit #528 is shorted to ground. Repair short, then go to CEL-30.</p> <p>Go to Chart 5, page H-71.</p>
<p>CEL-30 Verify Repairs</p> <ul style="list-style-type: none"> • Turn ignition off. • Reconnect all connectors. • Turn ignition on. • Clear codes. • Turn ignition off. • Turn ignition on while at the same time observing the "Check Engine" light. 	<p>"Check Engine" light comes on for up to 5 seconds, then goes out. →</p> <p>"Check Engine" light is flashing. →</p> <p>"Check Engine" light comes on and stays on. →</p>	<p>Repairs are complete.</p> <p>All system diagnostics are complete. Please review this section from the first step to find the error.</p> <p>Go to START-1, page H-25.</p>

Section 4 TROUBLESHOOTING CHARTS

D. CHART -11 - INTERMITTENT CODE OR A SYMPTOM AND NO CODES

NOTE: This chart is only to be used if:

- 1) All basic mechanical checks and physical inspections have been performed with no problem found, and
- 2) Diagnosis of DDEC-III/IV was started at step START-1, page H-25 and you have now been referred here.

STEP/SEQUENCE	RESULT	WHAT TO DO NEXT
<p>C 1-1 Diagnosis by Symptom</p> <ul style="list-style-type: none"> • Turn ignition off. • Go to appropriate result in the next column based on engine symptom. 	<p>Intermittent code. —————→</p> <p>Engine cranks but will not start. —————→</p> <p>Erratic performance and No Codes. —————→</p> <p>No "Check Engine" light during bulb check. —————→</p> <p>"Check Engine" light always on and No Codes. —————→</p> <p>"Check Gauges" light always on, and No codes. —————→</p> <p>No data to DDR. —————→</p> <p>No "Check Gauges" light during bulb check. —————→</p> <p>Diagnostic request switch inoperative. —————→</p> <p>Power Take-off (PTO) inoperative. —————→</p>	<p>Go to Chart 1, page H-40.</p> <p>Go to Chart 2, page H-43.</p> <p>Go to Chart 3, page H-63.</p> <p>Go to Chart 4, page H-65.</p> <p>Go to Chart 5, page H-71.</p> <p>Go to Chart 6, page H-75.</p> <p>Go to Chart 7, page H-79.</p> <p>Go to Chart 8, page H-85.</p> <p>Go to Chart 9, page H-91.</p> <p>Go to Chart 10, page H-95.</p>

Section 4

TROUBLESHOOTING CHARTS (Cont'd)

D. CHART -1 - INTERMITTENT CODE OR A SYMPTOM AND NO CODES (Cont'd)

STEP/SEQUENCE

C 1-2 **Diagnosis of an Intermittent Code or Symptom**

NOTE: Do not use any other procedures in this manual (except for the suggestions listed below) when trying to solve an intermittent problem. Use of any other procedures for this kind of problem can result in the replacement of non-defective parts.

Many intermittent problems are caused by faulty electrical connectors or wiring. Diagnosis must include a careful inspection of the indicated circuit wiring and connectors. Example: an intermittent Code 35 (Oil Pressure Sensor High) should cause suspicion of a problem in the following areas associated with the Oil Pressure Sensor.

1. Wire #'s 530 (signal line), 416 (+5 volt line) or 452 (ground line).
2. The Oil Pressure Sensor connector or ECM connector.
3. An intermittent in the Oil Pressure Sensor (least likely).

A good check list to run through includes the following:

1. Check for poor mating of the connector halves or terminals not fully seated in the connector body ("backed-out" terminals).
2. Look for improperly formed or damaged terminals. All connector terminals in the problem circuit should be carefully reformed to contact tension.
3. Electrical system interference caused by a defective relay, ECM driven solenoid, or a switch causing an electrical surge. Look for problems with the charging system (alternator, etc.). In certain cases, the problem can be made to occur when the faulty component is operated (as in the case of a relay).

After repairs or adjustments have been made, clear the codes and confirm that the "Check Engine" light does not come on (except for the 5 second bulb check when the ignition is first turned on). Also run the engine to see if that problem is cured. If the "Check Engine" light stays on, refer to the START-10 Chart on page H-25.

Refer to the DDR instructions manual. Using the "Snapshot" function may assist in isolating the cause for the problem. This function is useful in troubleshooting many areas of the DDEC System.

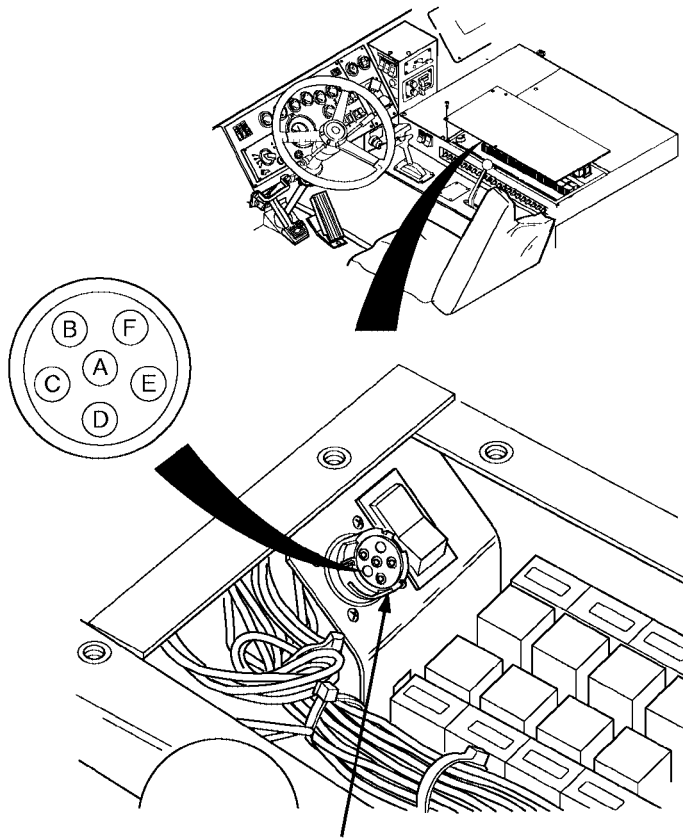

DDL CONNECTOR MC13

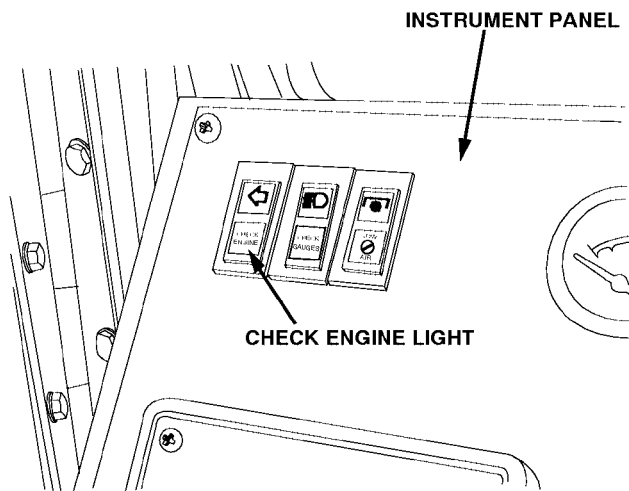

Section 4 TROUBLESHOOTING CHARTS

D. CHART -12 - ENGINE CRANKS BUT WILL NOT START

NOTE: This chart is only to be used if:

- 1) All basic mechanical checks and physical inspections have been performed with no problem found, and
- 2) Diagnosis of DDEC-III/IV was started at step START-1, pg H-25 and you have now been referred here.

STEP/SEQUENCE	RESULT	WHAT TO DO NEXT
<p>C 2-32 Observe “Check Engine” Light Status</p> <hr/> <ul style="list-style-type: none"> • Turn ignition on while observing the “Check Engine” light. 	<p>“Check Engine” light comes on for up to 5 seconds, then goes out. → Go to C 2-34.</p> <p>“Check Engine” light does not come on at all. → Go to C 2-48.</p> <p>“Check Engine” light comes on goes off and comes back on or stays on. → Go to C 2-33.</p>	
<p>C 2-33 Read Active Codes Using DDR</p> <hr/> <ul style="list-style-type: none"> • Plug DDR into the DDL connector. • Read active codes by selecting (ACTIVE CODES) on the DDR. 	<p>Active codes on DDR. → Follow appropriate diagnostic charts for code(s) received. (See Table of Contents on page ii)</p> <p>No codes. → Go to C 5-6.</p> <p>Display read “NO DATA BEING RECEIVED FROM SYSTEM or DDEC SYSTEM NOT RESPONDING” or a blank or random display. → Go to START-6, page H-29.</p>	
<p>C 2-34 Check if Out of Fuel</p> <hr/> <ul style="list-style-type: none"> • Check fuel supply. 	<p>Fuel supply okay. → Go to C 2-35.</p> <p>No fuel. → Refuel vehicle. May have to prime system (TM 9-2320-360-10). Then go to C 2-61.</p>	

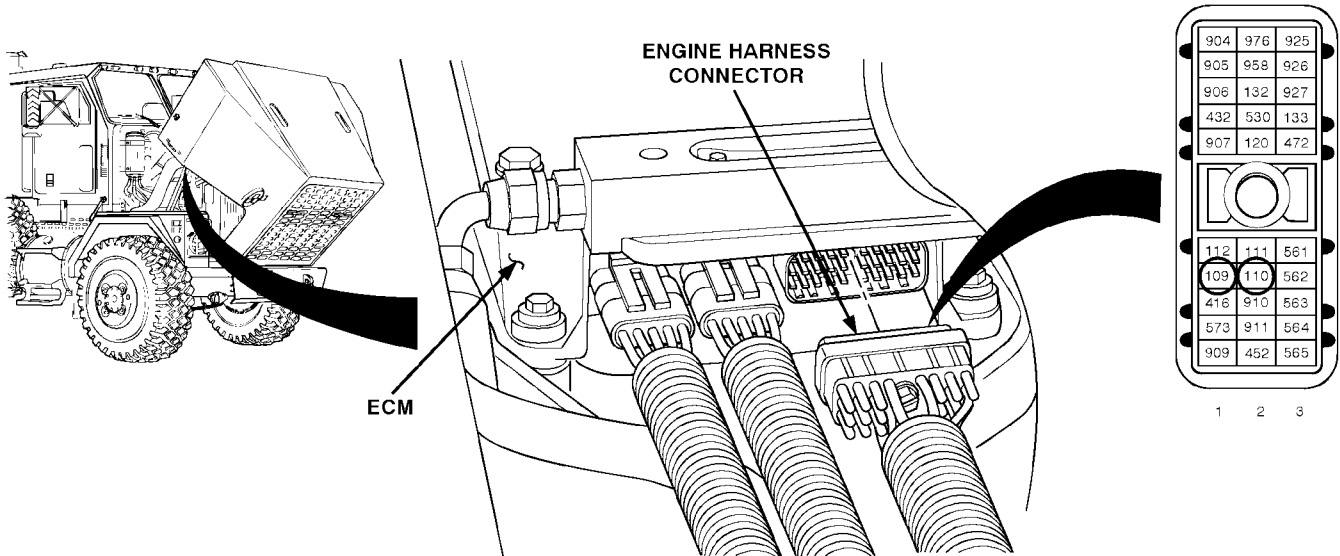
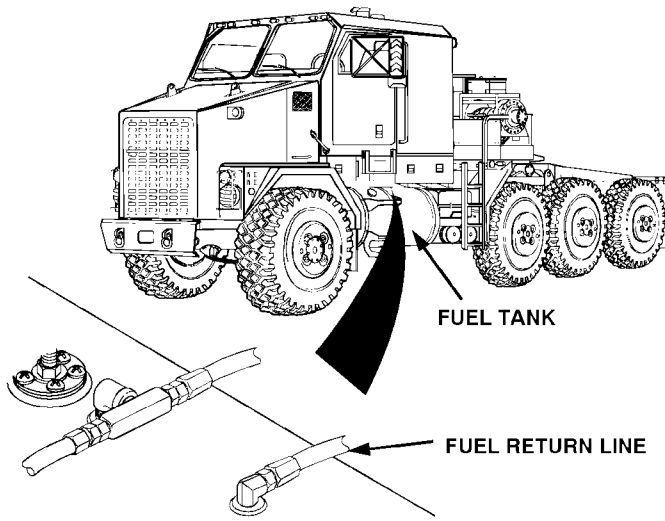

904	976	925
905	958	926
906	132	927
432	530	133
907	120	472
112	111	561
109	110	562
416	910	563
573	911	564
909	452	565
1	2	3

L
M
N
P
R

S
T
W
X
Y

Section 4 TROUBLESHOOTING CHARTS

D. CHART -12 - ENGINE CRANKS BUT WILL NOT START (Cont'd)

STEP/SEQUENCE	RESULT	WHAT TO DO NEXT
C 2-35 Check for Aerated Fuel		
<ul style="list-style-type: none"> • Loosen fuel return line. • Observe fuel flow out of line while cranking. (You can direct the fuel into a bucket.) 	<p>Flow is steady. →</p> <p>No flow or intermittent flow. →</p>	<p>Go to C 2-36.</p> <p>Check fuel filter(s) and supply lines to determine cause of problem (refer to Chapter 2, Vehicle Troubleshooting, for details).</p>
C 2-36 Check for White Smoke		
<ul style="list-style-type: none"> • Reconnect fuel return line. • Look for white smoke coming out of the exhaust stack while cranking the engine. 	<p>White smoke. →</p> <p>No white smoke. →</p>	<p>Your problem appears to be with cylinder compression or restricted air intake. Notify supervisor.</p> <p>Go to C 2-62.</p>
C 2-37 Check TRS Status via RPM Read-out		
<ul style="list-style-type: none"> • Select ENGINE RPM on DDR. • Crank engine while observing DDR display. (NOTE: Battery voltage surge while cranking with electric starters may blank out or reset DDR.) 	<p>Display always reads greater than or equal to 60 RPM while cranking. →</p> <p>Display sometimes or always reads less than 60 RPM while cranking. →</p>	<p>Go to C 2-43.</p> <p>Go to C 2-38.</p>
C 2-38 Check TRS		
<ul style="list-style-type: none"> • Turn ignition off. • Disconnect engine harness connector at the ECM. • Read resistance between sockets T1 and T2 at the engine harness connector. 	<p>Between 100 and 200 ohms. →</p> <p>Less than 100 ohms. →</p> <p>Greater than 200 ohms. →</p>	<p>Go to C 2-39.</p> <p>Go to 41-6.</p> <p>Go to 41-7.</p>

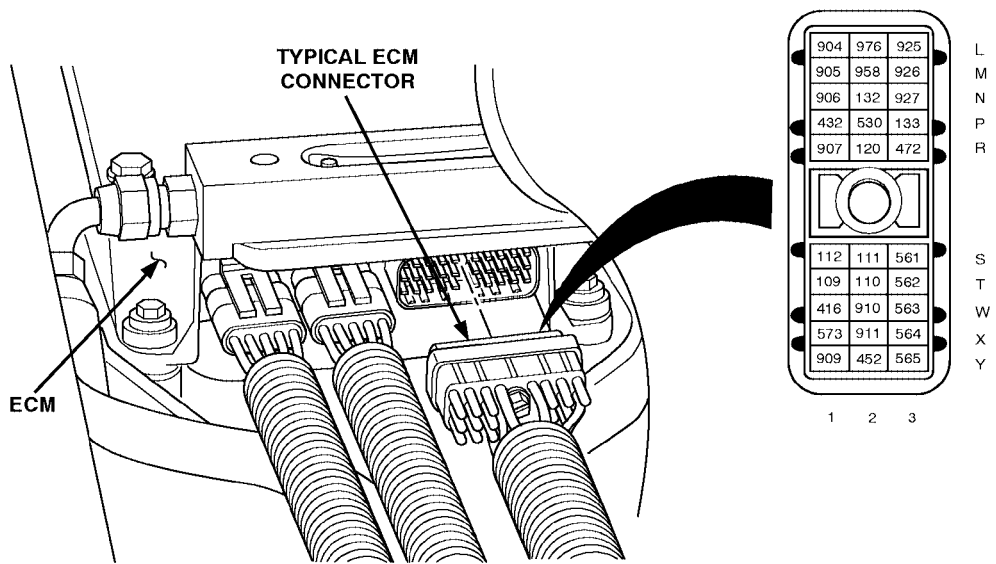
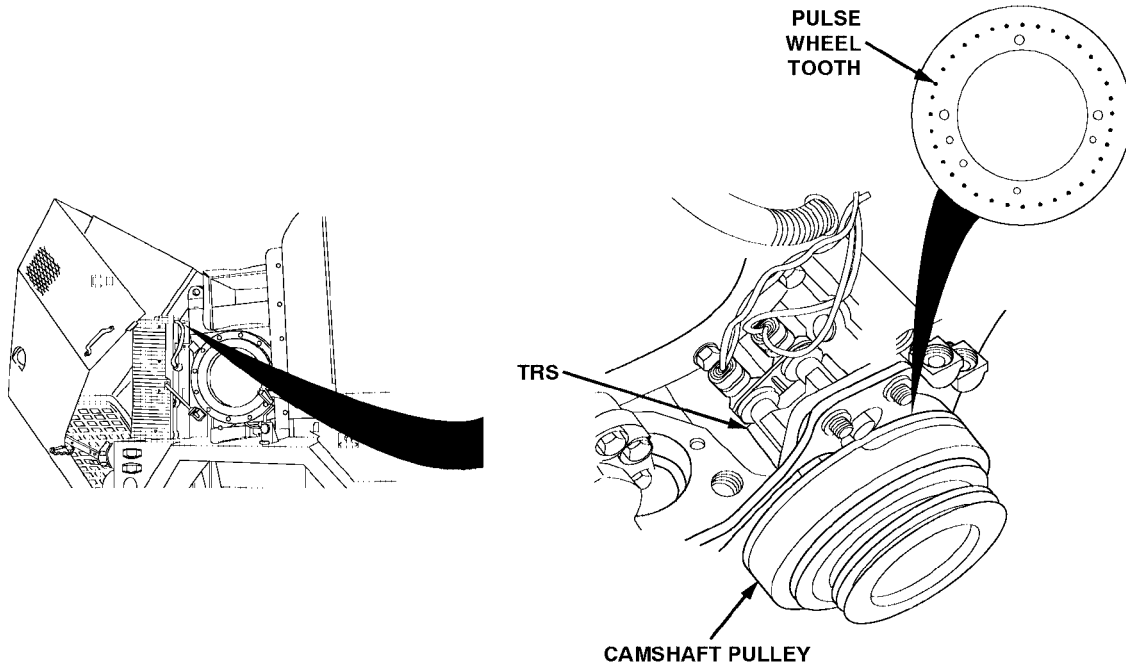

Section 4 TROUBLESHOOTING CHARTS

D. CHART -12 - ENGINE CRANKS BUT WILL NOT START (Cont'd)

STEP/SEQUENCE	RESULT	WHAT TO DO NEXT
<p>C 2-39 Check SRS/TRS Gap</p> <ul style="list-style-type: none"> • Remove ECM (para 7-29.1) • Turn camshaft counterclockwise until the TRS is over a TRS "tooth" of the pulse wheel. • Tap the front of the camshaft rearward with a soft hammer (to remove camshaft end play). • Using a feeler gauge check gap between the pulse wheel teeth and TRS (nominal gap is 0.020" or 0.5 mm). 	<p>Incorrect gap. →</p> <p>Gap setting is correct. →</p>	<p>Loosen the screw at the top of the TRS/SRS mounting bracket. (Don't touch the two screws that go into the block front end plate-they will affect engine timing.) Adjust the TRS/SRS until the gap setting is correct. Tighten screw. (If problems returns, pulse wheel may be loose or bad, notify supervisor.) Then go to C 2-61.</p> <p>Go to C 2-41.</p>
<p>C 2-40 (Deleted)</p>		
<p>C 2-41 Check Pulse Wheel</p> <ul style="list-style-type: none"> • Inspect DDEC pulse wheel for: <ul style="list-style-type: none"> -Loose wheel. -Chipped or missing teeth. 	<p>Pulse wheel OK. →</p> <p>Problem found. →</p>	<p>Go to C 2-42.</p> <p>Pulse wheel requires repair or replacement. Notify supervisor.</p>
<p>C 2-42 Check ECM Connectors</p> <ul style="list-style-type: none"> • Turn ignition off. • Disconnect all connectors at the ECM. • Check terminal at all ECM connectors (both the ECM and harness side) for damage; bent, corroded and unseated pins or sockets. 	<p>Terminal and connectors are okay. →</p> <p>Problem found. →</p>	<p>Replace ECM (para 7-29.1). Then go to C 2-61.</p> <p>Repair terminals/connectors (para 7-77). Then go to C 2-61.</p>

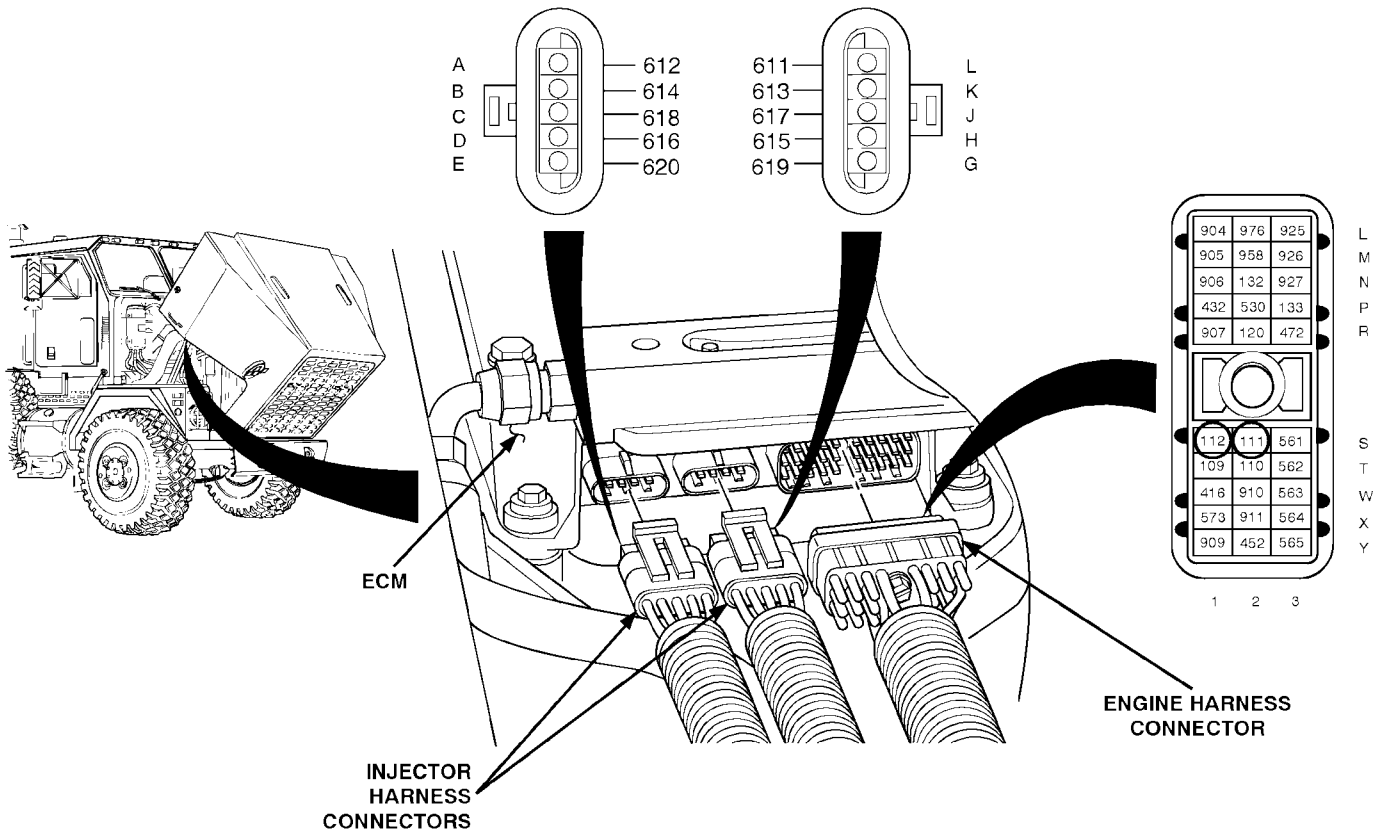

Section 4 TROUBLESHOOTING CHARTS

D. CHART -12 - ENGINE CRANKS BUT WILL NOT START (Cont'd)

STEP/SEQUENCE	RESULT	WHAT TO DO NEXT
<p>C 2-43 Check for Good SRS Signal</p> <ul style="list-style-type: none"> • Select engine data list on DDR. • Crank engine while observing DDR display of "SRS RECEIVED". (NOTE: Battery voltage surges while cranking with electric starters may blank out or reset DDR.) 	<p>Display reads SRS RECEIVED while cranking. →</p> <p>Display does not read SRS RECEIVED while cranking. →</p>	<p>Go to C 2-45.</p> <p>Go to C 2-44.</p>
<p>C 2-44 Check SRS</p> <ul style="list-style-type: none"> • Turn ignition off. • Disconnect engine harness connector at the ECM. • Read resistance between sockets S1 and S2 at the engine harness connector. 	<p>Between 100 and 200 ohms. →</p> <p>Less than 100 ohms. →</p> <p>Greater than 200 ohms. →</p>	<p>Go to C 2-39.</p> <p>Go to 41-2, page H-191.</p> <p>Go to 41-2, page H-191.</p>
<p>C 2-45 Check if Injector Return Wires are Open</p> <ul style="list-style-type: none"> • Turn ignition off. • Disconnect both injector harness connectors at the ECM. • Read resistance between the injector return pin and all the power driver pins on both harness connectors (example: G to L, and E to A). 	<p>Less than or equal to 5 ohms for any reading. →</p> <p>Greater than 5 ohms on any reading. →</p>	<p>Go to C 2-46.</p> <p>An open exists in one of the injector power driver or return wires. Repair open. Then go to C 2-61.</p>

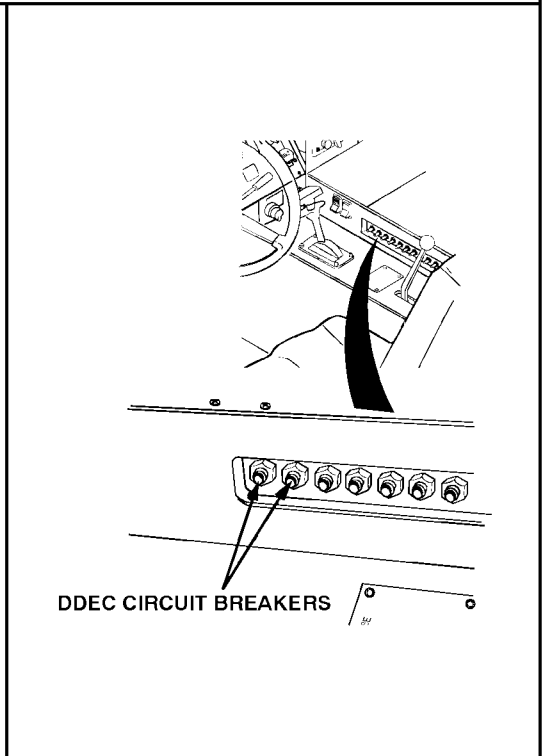
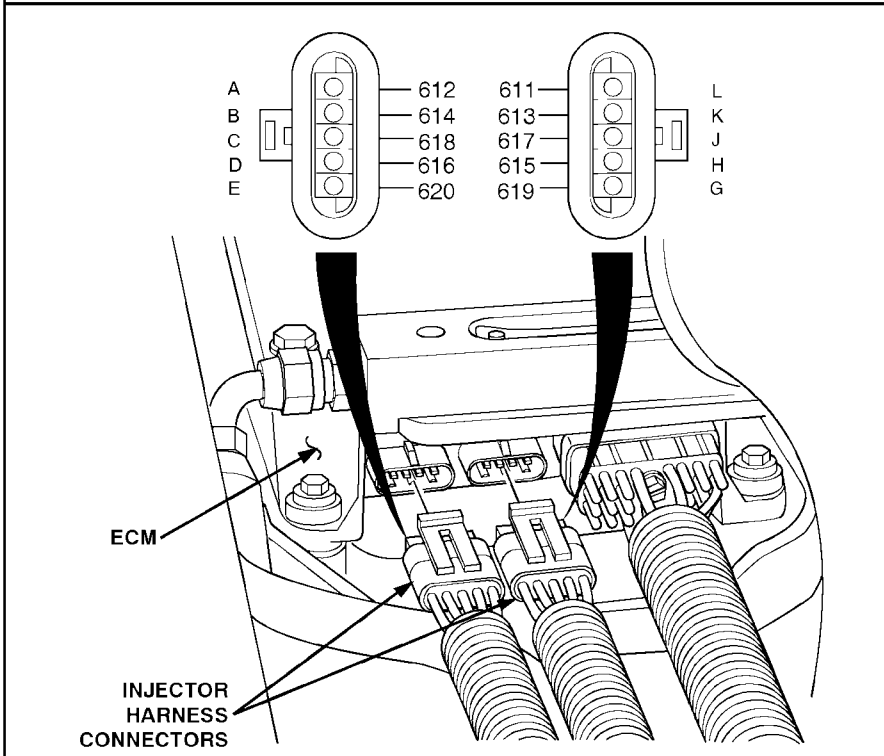
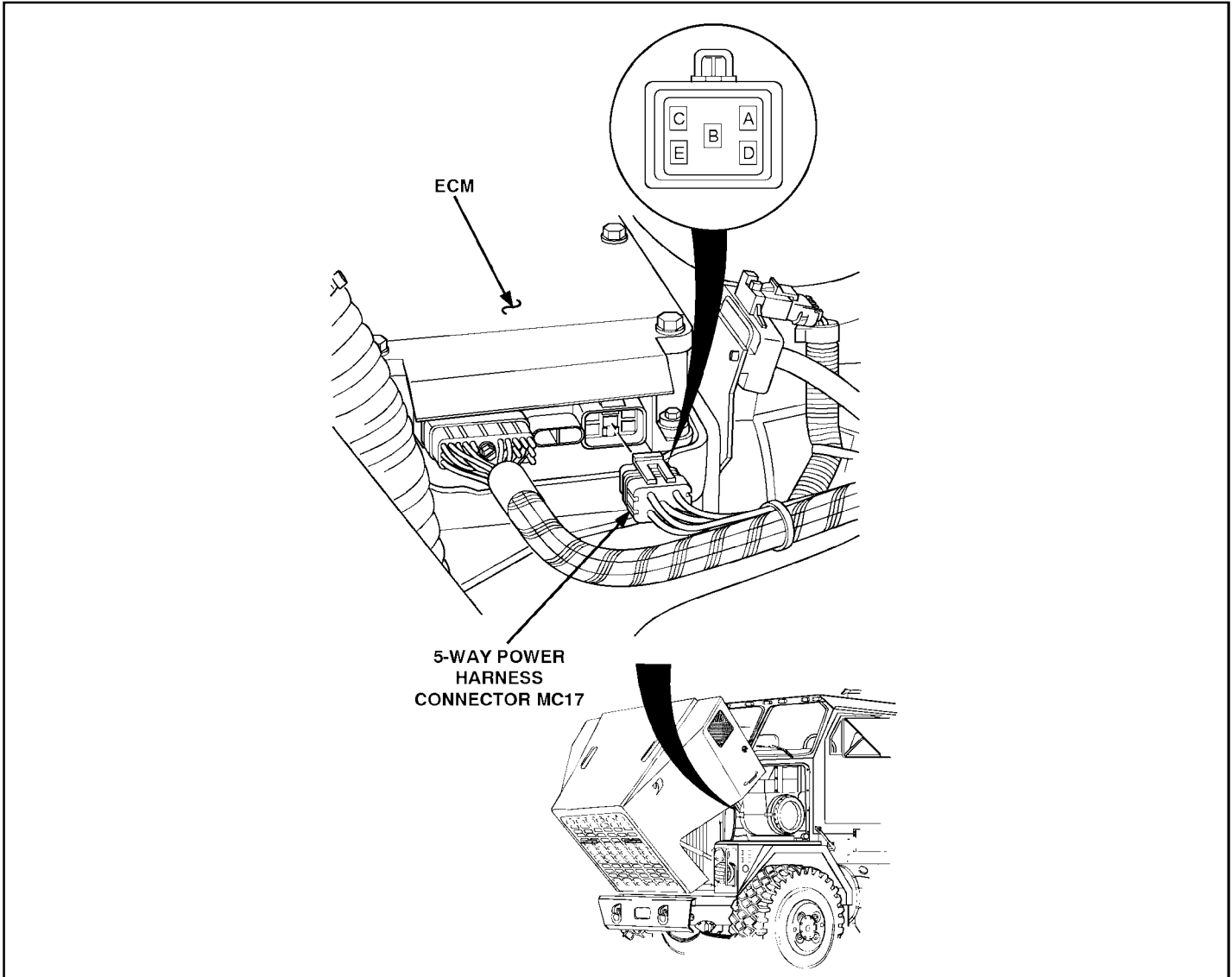

Section 4 TROUBLESHOOTING CHARTS

D. CHART -12 - ENGINE CRANKS BUT WILL NOT START (Cont'd)

STEP/SEQUENCE	RESULT	WHAT TO DO NEXT
<p>C 2-46 Check if Injector Drive or Return Lines are Shorted to Ground</p> <ul style="list-style-type: none"> • Disconnect the 5-way power harness connector at the ECM. • Read resistance between socket D of the 5-way power harness connector to the following sockets on the injector harness connectors: A, B, C, D, E, G, H, J, K, and L. 	<p>Greater than _____ or equal to 10,000 ohms or open on all readings.</p> <p>Less than 10,000 ohms on any reading.</p>	<p>→ Go to C 2-47.</p> <p>→ A short to ground on wire where resistance was less than 10,000 ohms. Repair short. Then go to C 2-61.</p>
<p>C 2-47 Injector Drive Pulses</p> <ul style="list-style-type: none"> • Turn ignition off. • Reconnect all ECM connectors. • Remove rocker arm cover(s) (para 3-2). • Place a 6 volt test light across the injector return side (return wire #619 or #620) and a good ground. • Crank engine and note if the test light flashes. • Reconnect the return wire. • Repeat the above procedure with all other injectors until all have been tested or until one test fails. 	<p>All tests pass.</p> <p>Light not flashing for one or more tests.</p>	<p>→ The problem does not appear to be in the DDEC system. Refer to Chapter 2, Vehicle Troubleshooting, for other possible causes of a no-start condition.</p> <p>→ Go to C 2-42.</p>
<p>C 2-48 Check DDEC Circuit Breakers</p> <ul style="list-style-type: none"> • Check both DDEC circuit breakers (CB 20 + 21). 	<p>Open circuit breaker(s).</p> <p>Circuit breakers are okay.</p>	<p>→ Go to C 2-59.</p> <p>→ Go to C 2-49.</p>

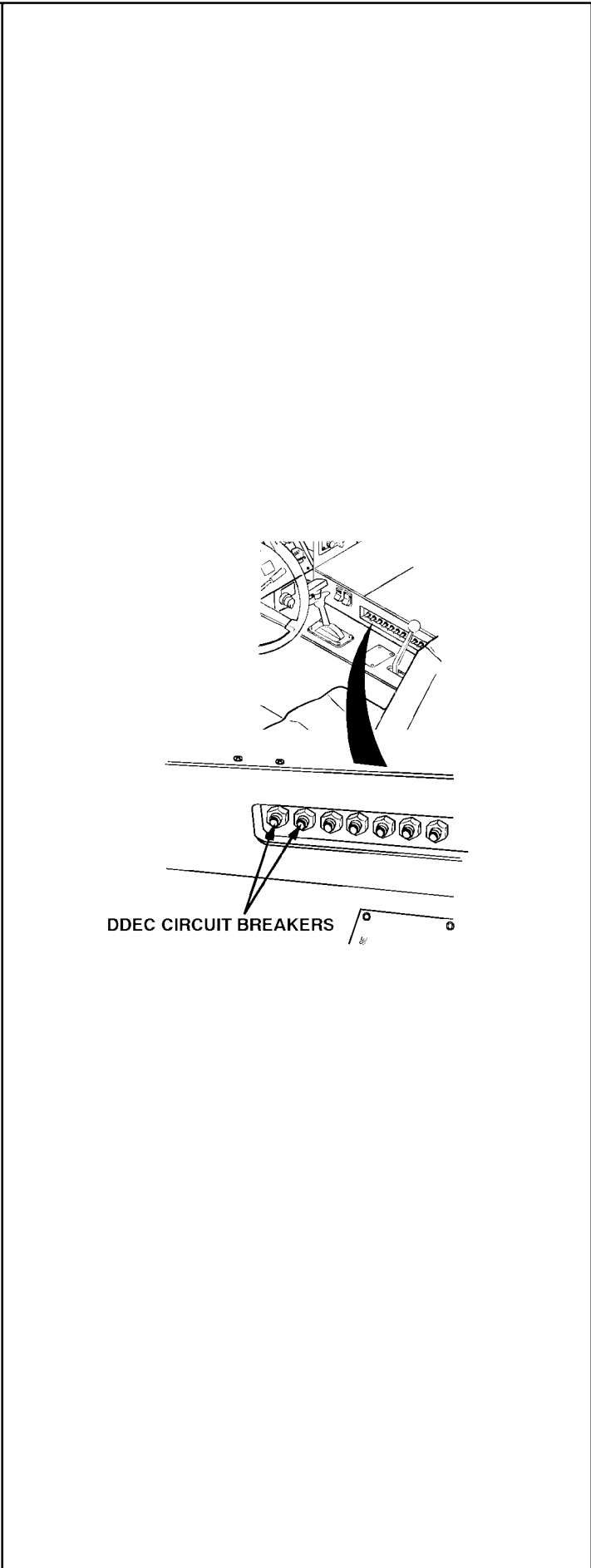
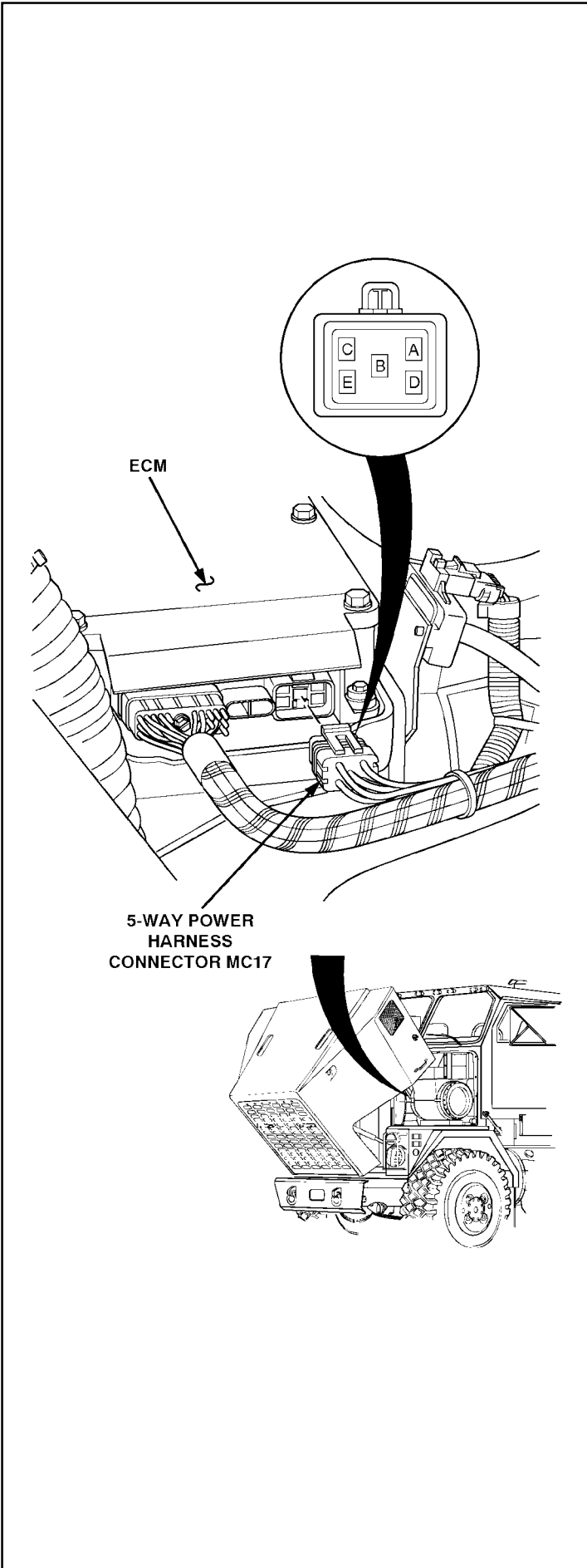

Section 4 TROUBLESHOOTING CHARTS

D. CHART -12 - ENGINE CRANKS BUT WILL NOT START (Cont'd)

STEP/SEQUENCE	RESULT	WHAT TO DO NEXT
<p>C 2-49 Check for Battery Volts at the 5-way Power Harness Connector</p>		
<ul style="list-style-type: none"> • Turn ignition off. • Disconnect the 5-way power harness connector. • Read voltage from socket A (red lead) of 5-way power harness connector to a good ground (black lead). • Also read voltage from socket C (red lead) to a good ground (black lead). 	<p>Less than 11.5 volts on any reading. →</p> <p>Greater than 11.5 volts on all readings. →</p>	<p>Go to C 2-50.</p> <p>Go to C 2-52.</p>
<p>C 2-50 Check if ECM Power Line(s) are Open.</p>		
<ul style="list-style-type: none"> • Read voltage between battery side of one DDEC circuit breaker (red lead) and a good ground (black lead). • Read voltage reading at the other DDEC circuit breaker. (NOTE: Battery side does not contain #240 or #241 wires.) 	<p>Less than 11.5 volts on either reading. →</p> <p>Greater than 11.5 volts on both readings. →</p>	<p>Go to C 2-51.</p> <p>An open exists in either Power line (ckt #240) or (ckt #241). Repair open. Then go to C 2-61.</p>
<p>C 2-51 Check Battery</p>		
<ul style="list-style-type: none"> • Connect all connectors. • Turn ignition on. • Try to start engine. • Read voltage at battery + terminal (red lead) to the battery - terminal (black lead). 	<p>Less than 10.0 volts. →</p> <p>Greater than or equal to 10.0 volts. →</p>	<p>Service discharged battery (TM 9-6140-200-14). (NOTE: If a short to ground exists anywhere in a battery + circuit, the engine will shut down again if not repaired.) Then go to C 2-61.</p> <p>An open or short to ground exists in the Batt + line. Repair open or short to ground. Then go to C 2-61.</p>

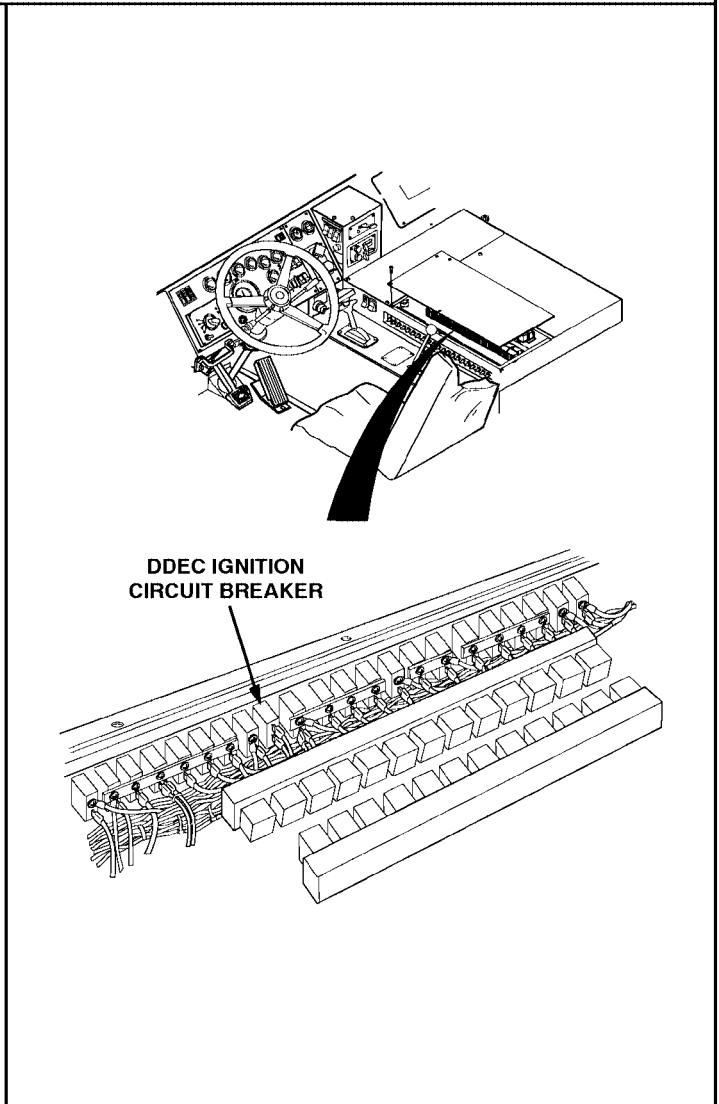
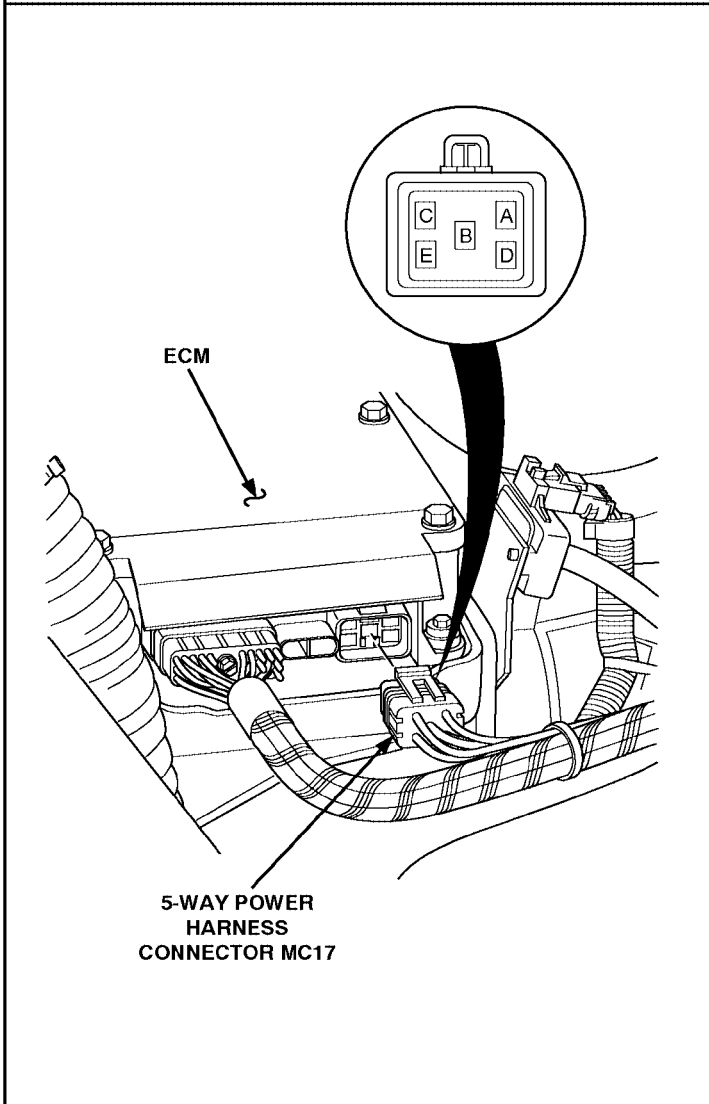
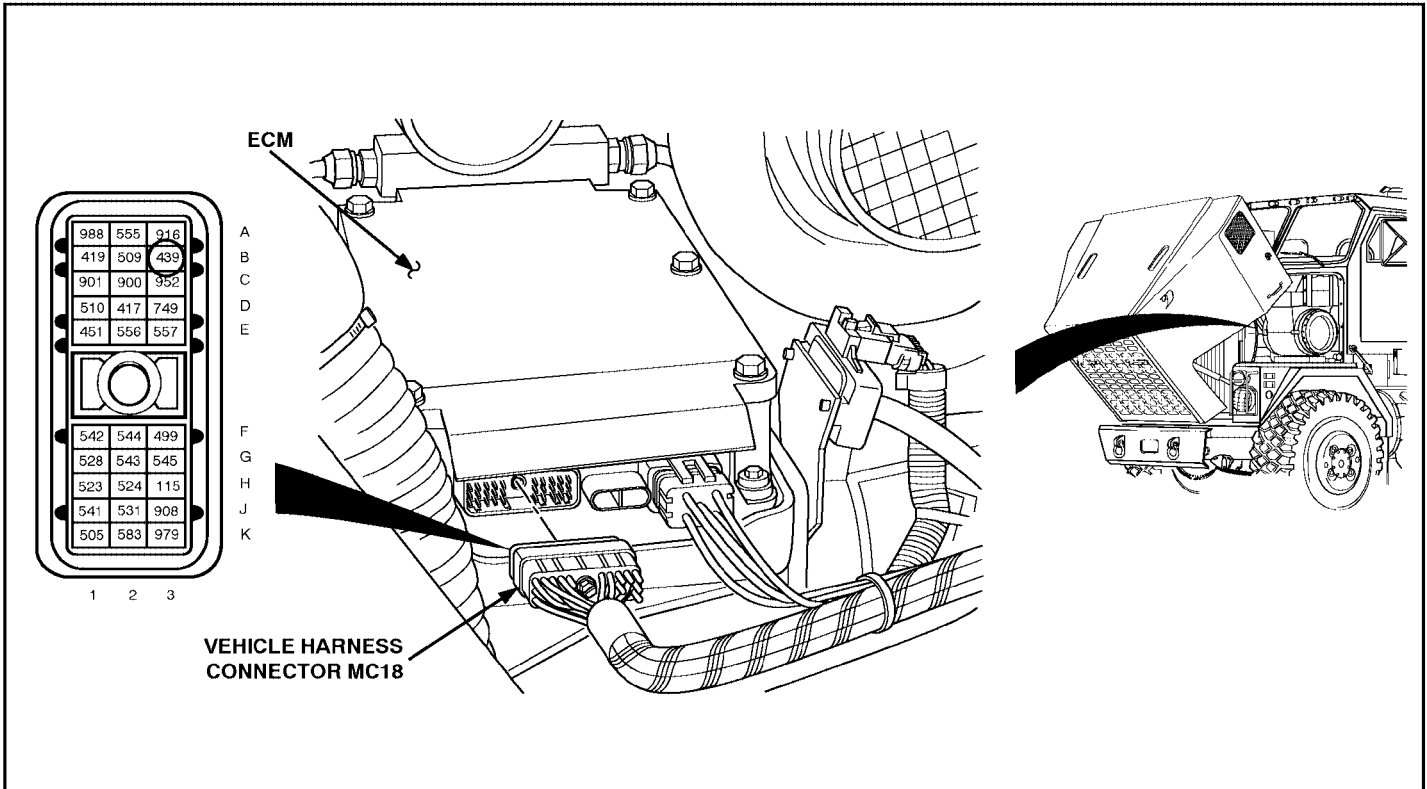

Section 4 TROUBLESHOOTING CHARTS

D. CHART -12 - ENGINE CRANKS BUT WILL NOT START (Cont'd)

STEP/SEQUENCE	RESULT	WHAT TO DO NEXT
<p>C 2-52 Check for +12 or +24 Volts at Ignition Wire</p> <ul style="list-style-type: none"> • Turn ignition off. • Disconnect vehicle harness connector at ECM. • Turn ignition on. • Read voltage between socket B3 on the vehicle harness connector (red lead) and a good ground (black lead). 	<p>Less than 11.5 volts. →</p> <p>Greater than or equal to 11.5 volts. →</p>	<p>Go to C 2-54.</p> <p>Go to C 2-53.</p>
<p>C 2-53 Check for Good Ground Wire</p> <ul style="list-style-type: none"> • Read voltage between socket B3 on vehicle harness connector (red lead) and socket D and E on 5-way power harness. 	<p>Less than 11.5 volts. →</p> <p>Greater than or equal to 11.5 volts. →</p>	<p>ECM ground wire (ckt #150) is open or has a poor connection. Repair open or poor connection. Then go to C 2-61.</p> <p>Go to C 2-42.</p>
<p>C 2-54 Check if Ignition Circuit Breaker is Okay</p> <ul style="list-style-type: none"> • Turn ignition off. • Check DDEC ignition circuit breaker (CB11). 	<p>Circuit breaker is okay. →</p> <p>Circuit breaker open. →</p>	<p>Go to C 2-55.</p> <p>Go to C 2-56.</p>

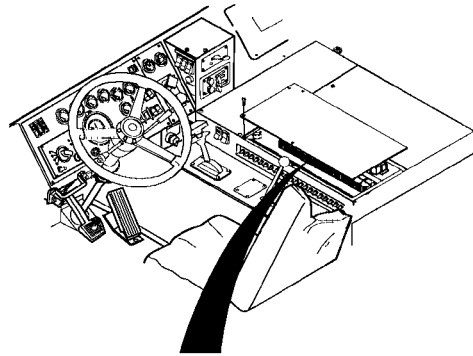

DDEC IGNITION
CIRCUIT BREAKER

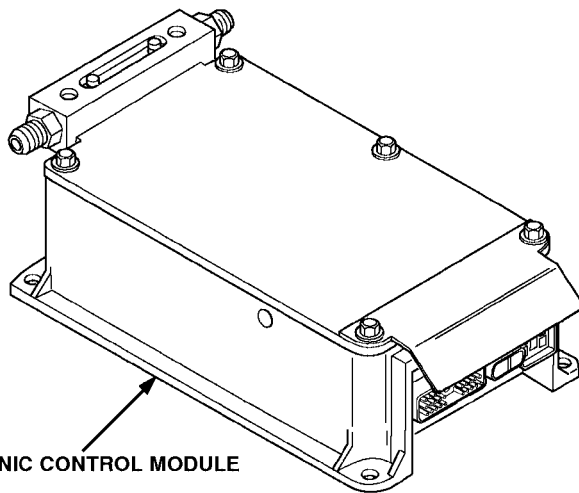
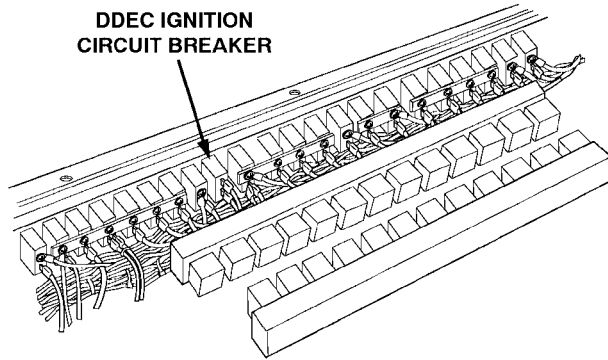

ELECTRONIC CONTROL MODULE

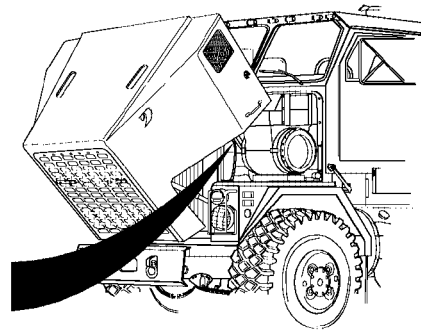

ECM SHOWN REMOVED FOR CLARITY

Section 4 TROUBLESHOOTING CHARTS

D. CHART -12 - ENGINE CRANKS BUT WILL NOT START (Cont'd)

STEP/SEQUENCE	RESULT	WHAT TO DO NEXT
<p>C 2-55 Check if Ignition Wire (Circuit #2) is Open</p>	<p>Less than 11.5 volts.</p>	<p>Go to C 2-58.</p>
<ul style="list-style-type: none"> • Read voltage between battery side (hot side) of the DDEC ignition circuit breaker (CB11) (red lead) and a good ground (black lead). 	<p>Greater than or equal to 11.5 volts.</p>	<p>Ignition line (ckt #439) is open. Repair open. Then go to C 2-61.</p>
<p>C 2-56 Check if Ignition Wire is Shorted to Ground</p>	<p>Circuit breaker is still okay.</p>	<p>Go to C 2-57.</p>
<ul style="list-style-type: none"> • Reset open circuit breaker. • Turn ignition on for at least 10 seconds. • Turn ignition off. • Check DDEC ignition circuit breaker (CB11) again. 	<p>Circuit breaker open.</p>	<p>Ignition line (ckt #439) is shorted to ground. Repair short. Then go to C 2-61.</p>
<p>C 2-57 Check if Ignition Circuit Breaker is Okay</p>	<p>Circuit breaker is still okay.</p>	<p>No short is currently present. (WARNING: if there is an intermittent short, engine will shut down again if not repaired. Also note circuit breaker may have blown due to temporary reverse voltage at the battery.) Go to C 2-61.</p>
<ul style="list-style-type: none"> • Reconnect all harness connectors at ECM. • Attempt to start • If engine starts, run engine for at least one minute. • Turn ignition off. • Check DDEC ignition circuit breaker. 	<p>Circuit breaker open.</p>	<p>Go to C 2-42.</p>

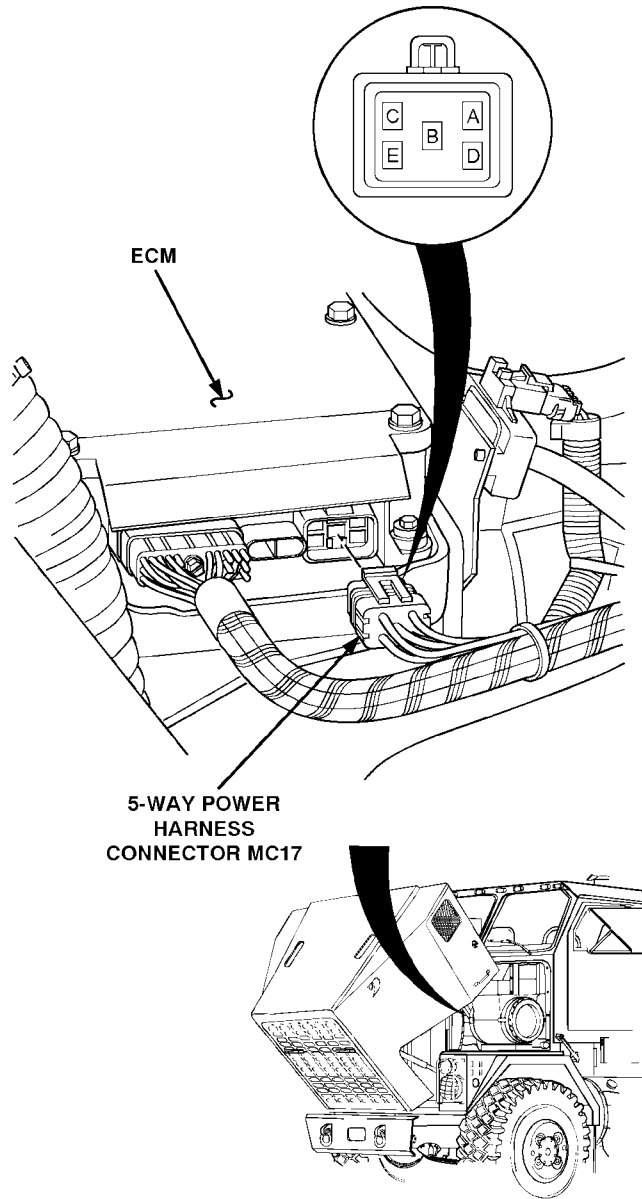

Section 4 TROUBLESHOOTING CHARTS

D. CHART -12 - ENGINE CRANKS BUT WILL NOT START (Cont'd)

STEP/SEQUENCE	RESULT	WHAT TO DO NEXT
<p>C 2-58 Check Battery</p> <hr/> <ul style="list-style-type: none"> • Disconnect battery cables at battery (para 7-61). • Read voltage at battery + terminal (red lead) to battery - terminal (black lead). 	<p>Less than 11.5 volts. →</p> <p>Greater than or equal to 11.5 volts. →</p>	<p>Service discharged battery (TM 9-6140-200-14). (NOTE: if a short to ground exists anywhere in battery + circuit, this vehicle will shut down again if not repaired.) Then go to C 2-61.</p> <p>An open or short to ground exists in unfused ignition line (ckt #1866). Repair open or short to ground. Then go to C 2-61.</p>
<p>C 2-59 Check if Fuses Blow Again</p> <hr/> <ul style="list-style-type: none"> • Turn ignition off. • Disconnect the 5-way power harness connector at ECM. • Reset DDEC circuit breaker(s). • Wait 10 seconds. • Check if circuit breaker(s) has blown or opened up again. 	<p>Circuit breaker(s) are still okay. →</p> <p>Circuit breaker(s) are blown or open again. →</p>	<p>Go to C 2-57.</p> <p>Go to C 2-60.</p>
<p>C 2-60 Check for Short to Ground in Wiring</p> <hr/> <ul style="list-style-type: none"> • Read resistance between (ckt #240) and a good ground. • Read resistance between (ckt #241) and a good ground. 	<p>Greater than or equal to 10,000 ohms or open on all readings. →</p> <p>Less than 10,000 ohms on any reading. →</p>	<p>Go to C 2-42.</p> <p>Short to ground exists. Repair short(s). Then go to C 2-61.</p>

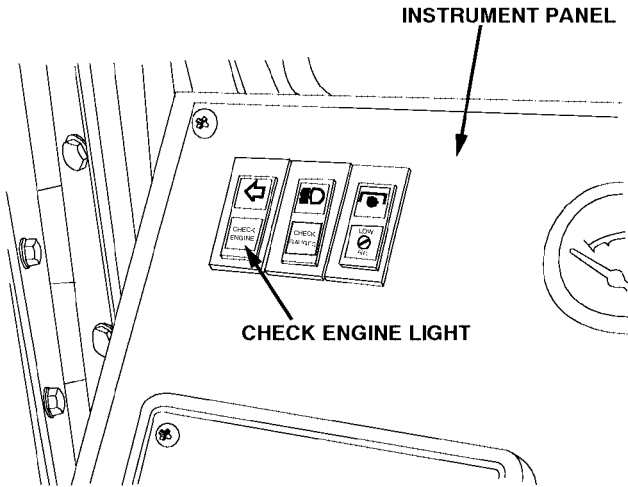

Section 4 TROUBLESHOOTING CHARTS

D. CHART -12 - ENGINE CRANKS BUT WILL NOT START (Cont'd)

STEP/SEQUENCE	RESULT	WHAT TO DO NEXT
<p>C 2-61 Verify Repairs</p> <ul style="list-style-type: none"> • Turn ignition off. • Reconnect all connectors. • Turn ignition on. • Clear codes. • Note status of "Check Engine" light. • If "Check Engine" light does not stay on, start engine and run (TM 9-2320-360-10) for 1 minute or until "Check Engine" light comes on. Stop engine. • Read inactive codes. 	<p>Engine will not start. →</p> <p>Engine starts and DDR reads No codes. →</p> <p>Engine starts codes appear. →</p>	<p>All system diagnostics are complete. Please review this section from the first step to find error.</p> <p>Repairs are complete.</p> <p>Go to START-1, pg H-25, to service codes.</p>
<p>C 2-62 Check Fuel Filters</p> <ul style="list-style-type: none"> • Turn ignition off. • Check primary and secondary fuel filters to be sure they are not clogged and that they are full of clean fuel. 	<p>Clogged filter(s). →</p> <p>Clean filters and no air in filters. →</p>	<p>Service fuel/water separator (para 4-11). Replace secondary filter (para 4-13). Prime system (TM 9-2320-360-10), if required. Then go to C 2-61.</p> <p>Go to C 2-37.</p>

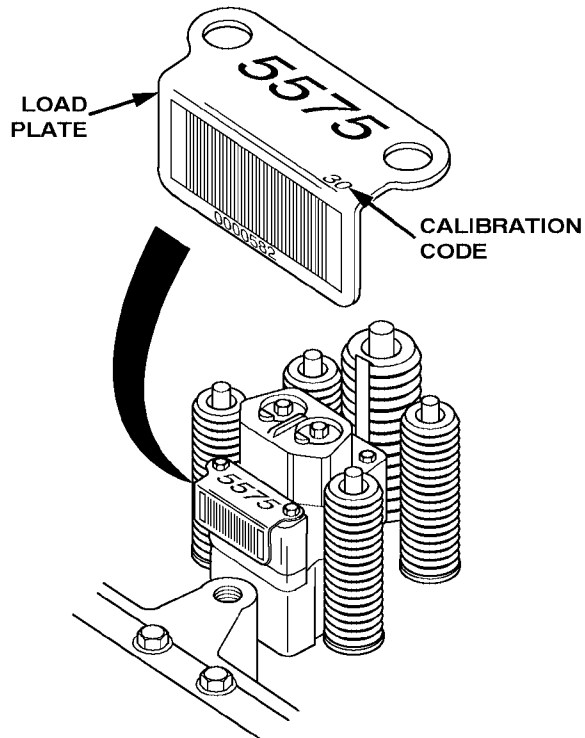
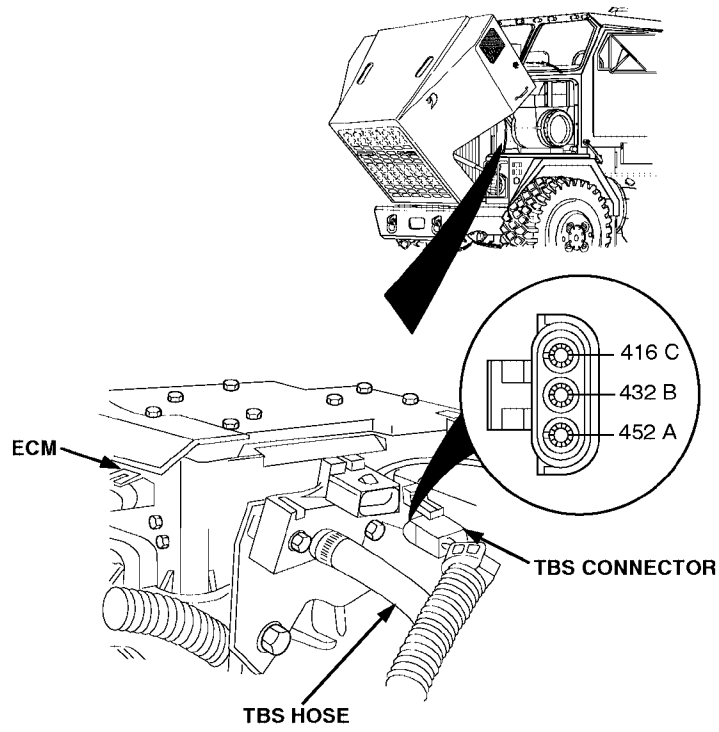

Section 4 TROUBLESHOOTING CHARTS

D. CHART -13 - ERRATIC PERFORMANCE AND NO CODES

This is a helpful hints chart. It assumes that you have received no codes, made all the basic mechanical checks first, could not find the problem, and suspect the DDEC III/IV system to be at fault. Based on the particular symptom here's what to look for:

SYMPTOM	WHAT TO LOOK FOR
1. Can't get full power.	<p>Plugged fuel filters. Hose not connected to Turbo Boost Sensor (TBS). Verify injector calibration(s) are correct: Remove rocker covers (para 3-2). Record the injector calibration codes found on the injector load plate for each injector. Compare the calibration codes with those on the DDR FUEL INJECTOR CAL display. Update calibration codes if necessary. See Section 5 for additional details. Install rocker covers (para 3-2).</p>
2. Can't get full throttle.	<p>Incorrect Throttle Position Sensor (TPS) counts. See Step 21-8 for details (page H-139).</p>
3. Runs rough, misses and/or occasionally stalls. C 2-39	<ul style="list-style-type: none"> • Proper gapping of Timing Reference & Synchronous Reference Sensors (SRS and TRS). See Step (para H-47) on how to check this. • Check for Fuel Leaks. • Loose battery power (ckt #240 or #241) ignition (ckt #439) or ground (ckt #150) wires. • Check power contribution from each cylinder using cylinder cut-out feature described in Diagnostic Data Reader (DDR) instruction manual. • Check pulse wheel: missing teeth, damaged or loose. • Check for signs of insulation wear on injector harnesses.
4. Engine idles high (after warm-up) or slow return to idle.	<ul style="list-style-type: none"> • Check calibration of Throttle Position Sensor (TPS) using procedure in Step 21-8 (page H-139). You may have a TPS or pedal problem. • Check vernier control signal line (ckt #525) for short to voltage source.

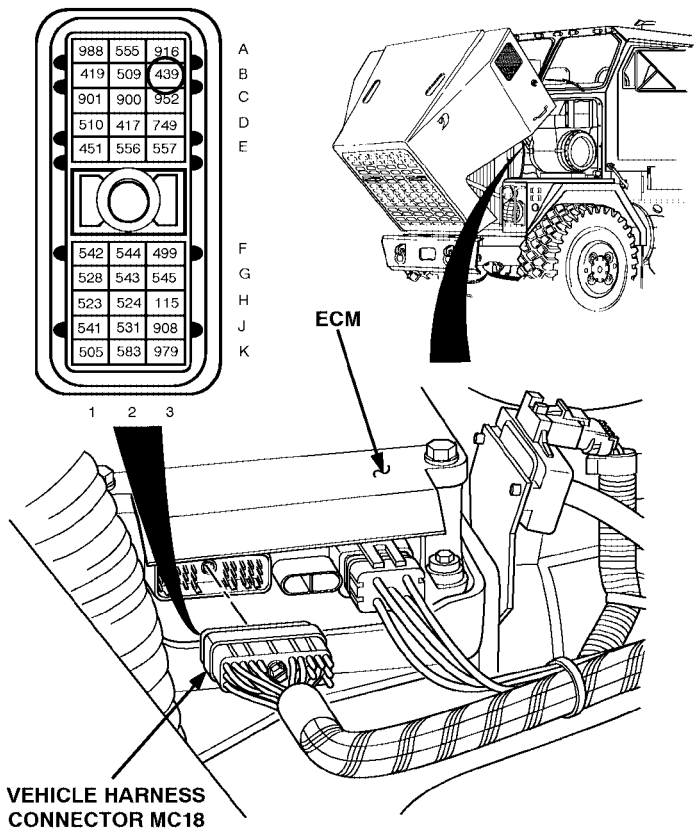
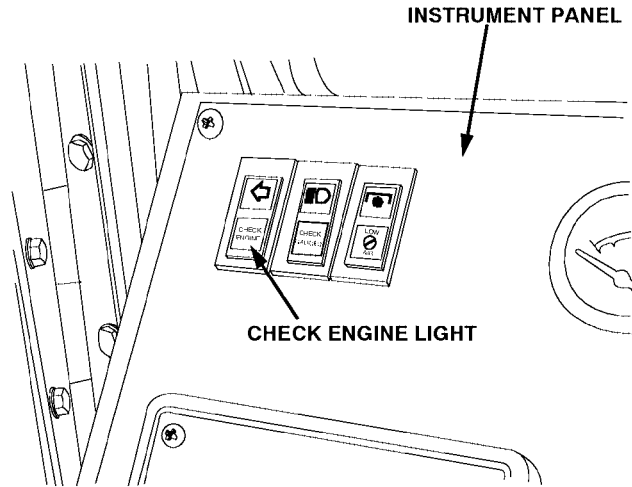

Section 4 TROUBLESHOOTING CHARTS

D. CHART -14 - NO "CHECK ENGINE" LIGHT DURING BULB CHECK OR CANNOT CLEAR CODES

NOTE - This chart is only to be used if:

- 1) All basic mechanical checks and physical inspections have been performed with no problem found, and
- 2) Diagnosis of DDEC-III/IV was started at step START-1, pg H-25 and you have now been referred here.

STEP/SEQUENCE	RESULT	WHAT TO DO NEXT
C 4-8 Try to Force CEL On		
<ul style="list-style-type: none"> • Plug in DDR. • Turn ignition on. • Select ACTIVATE OUTPUTS. • Activate "Check Engine" light. 	DDR display is blank or random. →	Go to C4-2.
	"Check Engine" light is still off. →	Go to C4-2.
	"Check Engine" light is still on. →	Go to C4-4.
C 4-9 Check for Ignition		
<ul style="list-style-type: none"> • Read voltage on vehicle harness connector, socket B3 (red lead) to a good ground (black lead) with the ignition on and engine off. 	Less than 10.0 volts. →	The DDEC ignition circuit breaker (CB11) is blown and/or ignition wires are open or shorted to ground, and/or the ignition line (ckt #439) is shorted to ground or is not wired to switch ignition source (See note below). Repair problem. Then go to C4-30.
	Greater than or equal to 10.0 volts. →	Go to C 4-10.
C 4-10 CEL Drive line and Bulb Check		
<ul style="list-style-type: none"> • Turn ignition off. • Remove CEL bulb and check whether it's burned out or otherwise damaged. 	Bulb is okay. →	CEL Driver line (ckt #419) or ground line (ckt #150) is open. Repair open. Then go to C4-30.
	Bulb is not okay. →	Replace bulb (para 7-40). Then go to C4-30.

*NOTE: Inactive codes will not clear and engine hours/fuel consumption values will not update if main ECM power (ckt #240 and #241) is switched off with or before ignition.

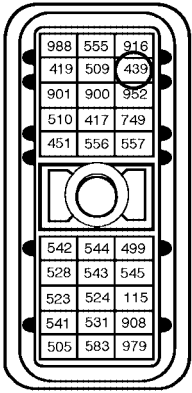

A
B
C
D
E

F
G
H
J
K

1 2 3

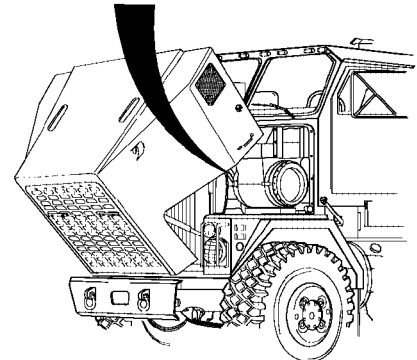
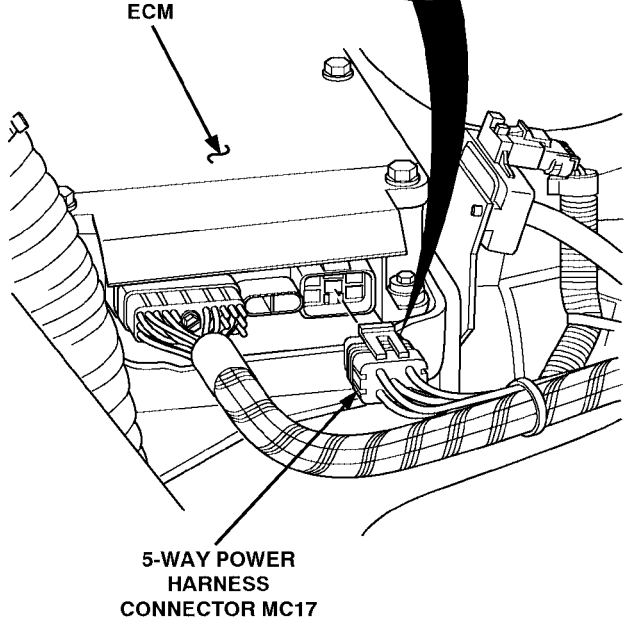
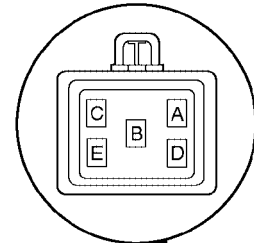
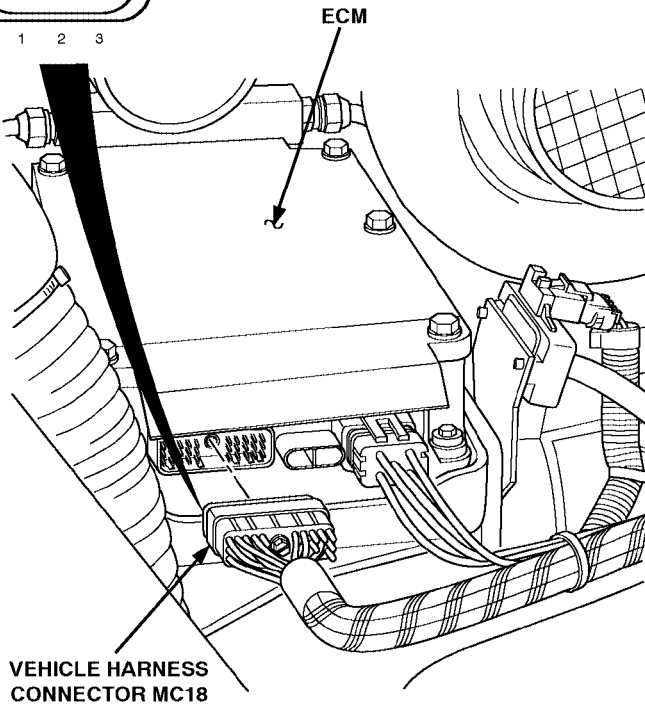

Section 4

TROUBLESHOOTING CHARTS

D. CHART -14 - NO "CHECK ENGINE" LIGHT DURING BULB CHECK OR CANNOT CLEAR CODES (Cont'd)

STEP/SEQUENCE	RESULT	WHAT TO DO NEXT
C 4-11 Check for Open		
<ul style="list-style-type: none"> • Remove jumper wire. With ignition on, read voltage on vehicle harness connector, socket B3 (red lead) to a good ground (black lead). 	Less than 10.0 volts. →	The ignition line (ckt #439) is open. Repair open. Then go to C4-30.
	Greater than or equal to 10.0 volts. →	Go to C 4-12.
C 4-12 Check for Bat +		
<ul style="list-style-type: none"> • Turn ignition off. • Disconnect the 5-way power harness connector. • Read voltage at the 5-way power harness connector. Socket A (red lead) to a good ground (black lead). • Repeat voltage readings on 5-way power harness connector, keeping the black lead to a good ground and the red lead to socket C. 	Less than 10.0 volts on any reading. →	Either one of the 20 Amp, DDEC circuit breakers (CB 20 + 21) is blown and/or the Battery Power line(s) (ckt #240 or #241) has an open or short to ground. Check that the battery power (ckt #240 and #241) are not switched off when the ignition is turned off (see note below). Repair problem. Then go to C4-30.
	Greater than or equal to 10.0 volts on readings. →	Go to C 4-13.

*NOTE: Engine update information may not update if main ECM power (ckt #240 and #241) is switched off with/or before ignition.

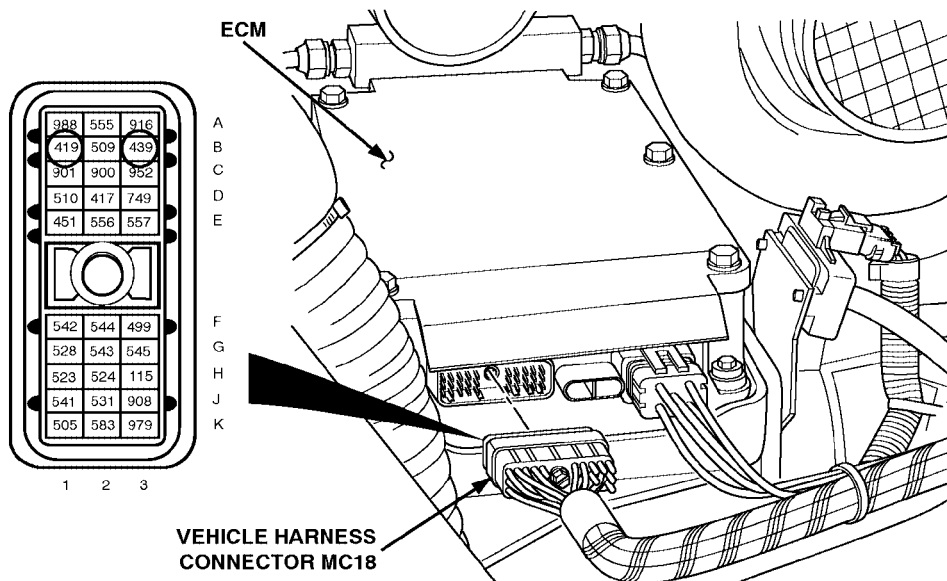
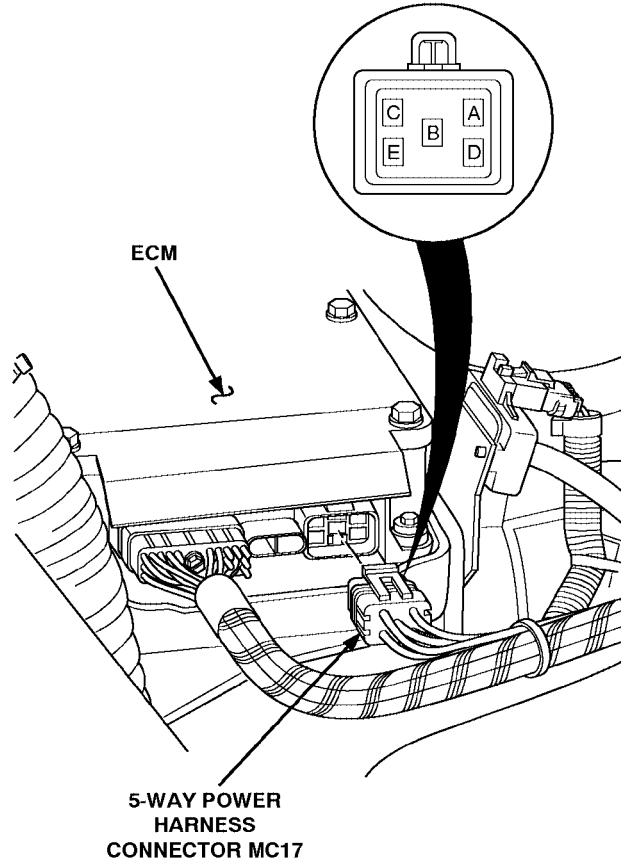

Section 4 TROUBLESHOOTING CHARTS

D. CHART -14 - NO "CHECK ENGINE" LIGHT DURING BULB CHECK OR CANNOT CLEAR CODES (Cont'd)

STEP/SEQUENCE	RESULT	WHAT TO DO NEXT
<p>C 4-13 Check for Open</p> <ul style="list-style-type: none"> • Move black lead of voltmeter to socket D (of the 5-way power harness connector). • Read voltage using red lead at sockets A and C of the 5-way power harness connector. • Move black lead of voltmeter to socket E of the 5-way power harness connector. • Again read voltage at sockets A, and C of the 5-way power harness connector. • Move black lead to socket B of 5-way. Check voltage at A and C. 	<p>Less than 10.0 volts on any reading. →</p> <p>Greater than or equal to 10.0 volts on all readings. →</p>	<p>Ground line(s) (ckt #150 or 151) has an open. Repair open. Then go to C4-30.</p> <p>Go to C 4-14.</p>
<p>C 4-14 Check ECM Connectors</p> <ul style="list-style-type: none"> • Check terminals at vehicle harness (especially B3 and B1) and all the terminals in the 5-way power harness connectors (both the ECM and harness side) for damage; bent, corroded and unseated pins or sockets. 	<p>Terminals and connectors are okay. →</p> <p>Problem found. →</p>	<p>Replace ECM (para 7-29.1). Then go to C4-30.</p> <p>Repair terminals/connectors (para 7-77). Then go to C4-30.</p>
<p>C 4-30 Verify Repairs</p> <ul style="list-style-type: none"> • Turn ignition off. • Reconnect all connectors. • Turn ignition on. • Clear codes. • Turn ignition off. • Turn ignition on while at the same time observing the "Check Engine" light. 	<p>"Check Engine" light comes on for up to 5 seconds, then goes out. →</p> <p>"Check Engine" light does not come on at all. →</p> <p>"Check Engine" light comes on and stays on. →</p>	<p>Repairs are complete.</p> <p>All system diagnostics are complete. Please review this section from the first step to find the error.</p> <p>Go to START-1, pg H-25.</p>

*NOTE: Historical codes will not clear and engine hours/fuel consumption values will not update if main ECM power (ckt #240 and #241) is switched off with ignition.

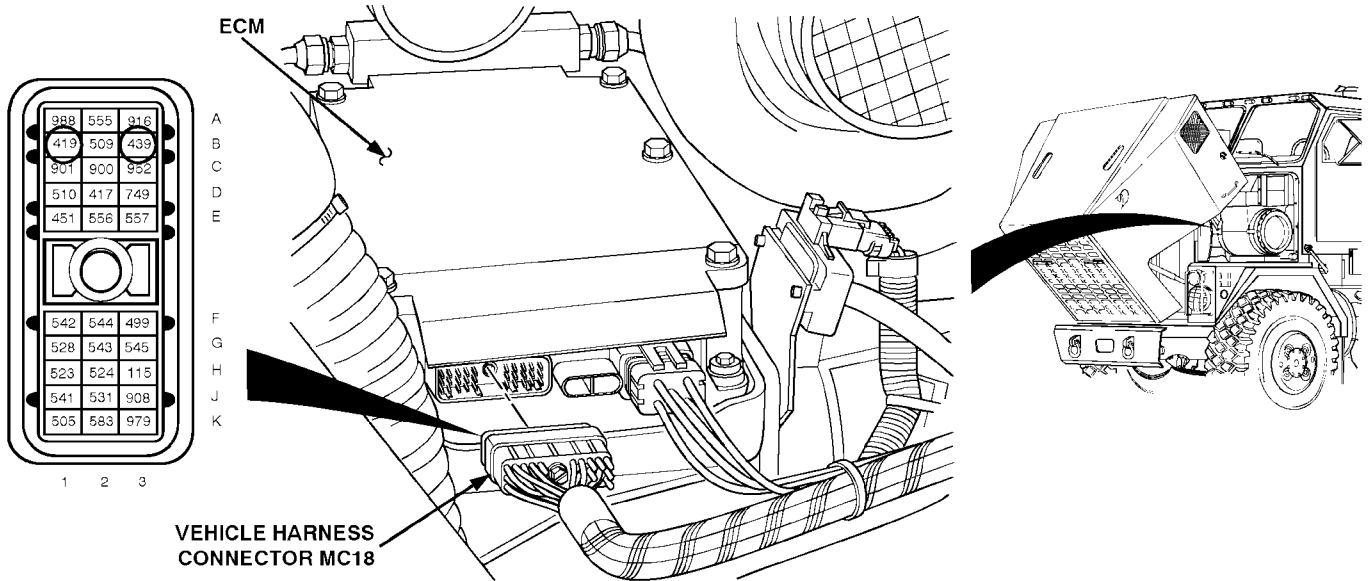
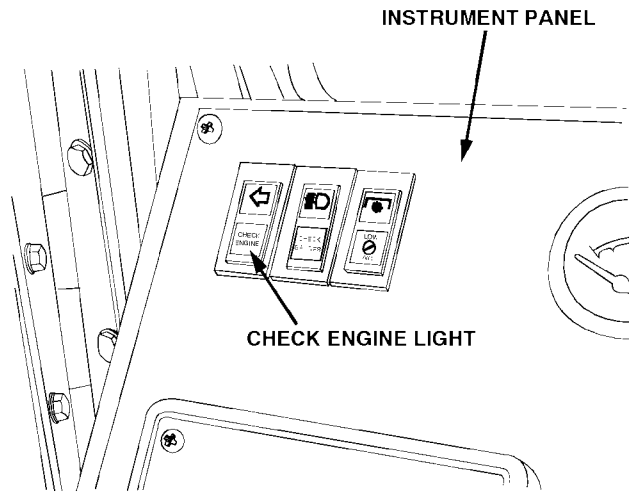

Section 4 TROUBLESHOOTING CHARTS

D. CHART -15 - "CHECK ENGINE" LIGHT ON AND NO ACTIVE CODE ON DDR

NOTE - This chart is only to be used if:

- 1) All basic mechanical checks and physical inspections have been performed with no problem found, and
- 2) Diagnosis of DDEC-III/IV was started at step START-1, pg H-25 and you have now been referred here.

This is a digital output function.

STEP/SEQUENCE	RESULT	WHAT TO DO NEXT
<p>C 5-6 Check for Short (Ckt #528)</p> <ul style="list-style-type: none"> • Turn ignition on. Observe "Check Engine" light. 	<p>Erratic or intermittent "Check Engine" light. →</p> <p>"Check Engine" light comes on and stays on. →</p>	<p>Check for short to ground on diagnostic request line (ckt #528). Repair short. Then go to C5-30.</p> <p>Go to C 5-7.</p>
<p>C 5-7 Check Light Status</p> <ul style="list-style-type: none"> • Plug in DDR. • Select SWITCH/LIGHT STATS. 	<p>CEL reads on. →</p> <p>CEL reads off. →</p>	<p>Go to C 5-9.</p> <p>Go to C 5-8.</p>
<p>C 5-8 Check for Short (Ckt #419)</p> <ul style="list-style-type: none"> • Turn ignition off. • Disconnect the vehicle harness connector at ECM. • Turn ignition on (engine not running) while at same time observing "Check Engine" light. 	<p>"Check Engine" light comes on and stays on. →</p> <p>"Check Engine" light stays off. →</p>	<p>CEL driver line (ckt #419) is shorted to ground. Repair short. Then go to C5-30.</p> <p>Go to C 5-9.</p>
<p>C 5-9 Force CEL On</p> <ul style="list-style-type: none"> • Install jumper wire between socket B1 of vehicle harness connector and a good ground. • Observe "Check Engine" light. 	<p>"Check Engine" light comes on and stays on. →</p> <p>"Check Engine" light stays off. →</p>	<p>Go to C 5-10.</p> <p>The ignition line (ckt #439) is not correctly wired to CEL bulb. See if bulb has been wired into ignition line (#439) instead of the proper #419 wire. Correct problem. Then go to C5-30.</p>

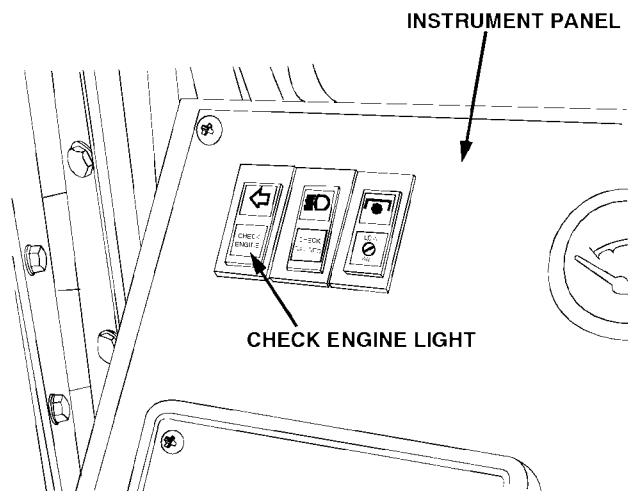
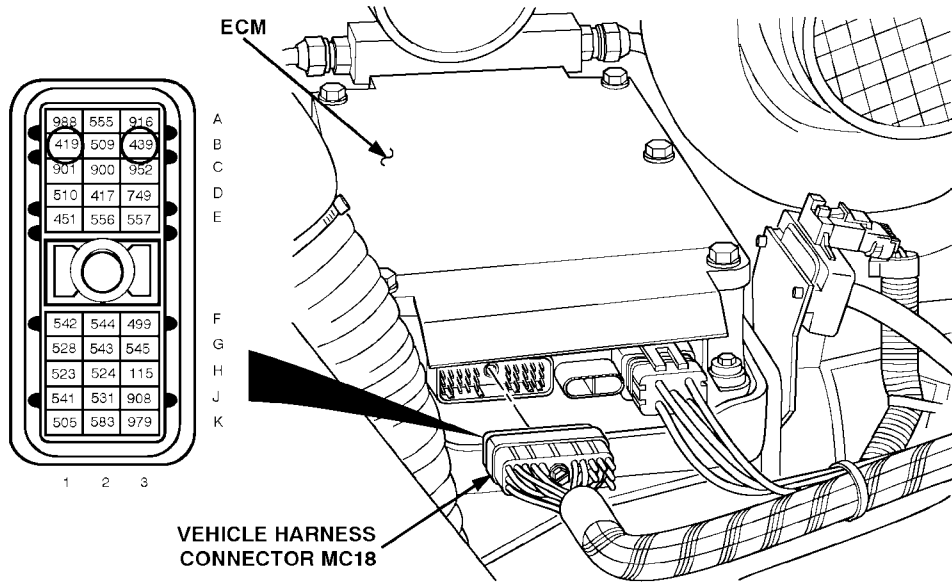

Section 4 TROUBLESHOOTING CHARTS

D. CHART -15 - "CHECK ENGINE" LIGHT ON AND NO ACTIVE CODE ON DDR (Cont'd)

STEP/SEQUENCE	RESULT	WHAT TO DO NEXT
<p>C 5-10 Check ECM Connectors</p> <ul style="list-style-type: none"> • Turn ignition off. • Check terminals at vehicle harness connectors (both ECM and harness side) for damage; bent, corroded and unseated pins or sockets. • Check terminals in connector to be sure B1 is wire #419 and B3 is wire #439. 	<p>Terminals and connectors are okay. →</p> <p>Problem found. →</p>	<p>Replace ECM (para 7-29.1). Then to go C5-30.</p> <p>Repair terminals/connectors (para 7-77). Then go to C5-30.</p>
<p>C 5-30 Verify Repairs</p> <ul style="list-style-type: none"> • Turn ignition off. • Reconnect all connectors. • Turn ignition on. • Clear codes. • Turn ignition off. • Turn ignition on while at same time observing "Check Engine" light. • If "Check Engine" light stays on, read inactive code. 	<p>"Check Engine" light comes on for up to 5 seconds, then goes out. →</p> <p>"Check Engine" light does not come on at all. →</p> <p>No active codes and "Check Engine" light comes on and stays on. →</p> <p>Fault codes present. →</p>	<p>Repairs are complete.</p> <p>Go to C 4-8.</p> <p>All system diagnostics are complete. Please review this section from first step to find the error.</p> <p>Go to START-1, pg H-25 to service other codes.</p>

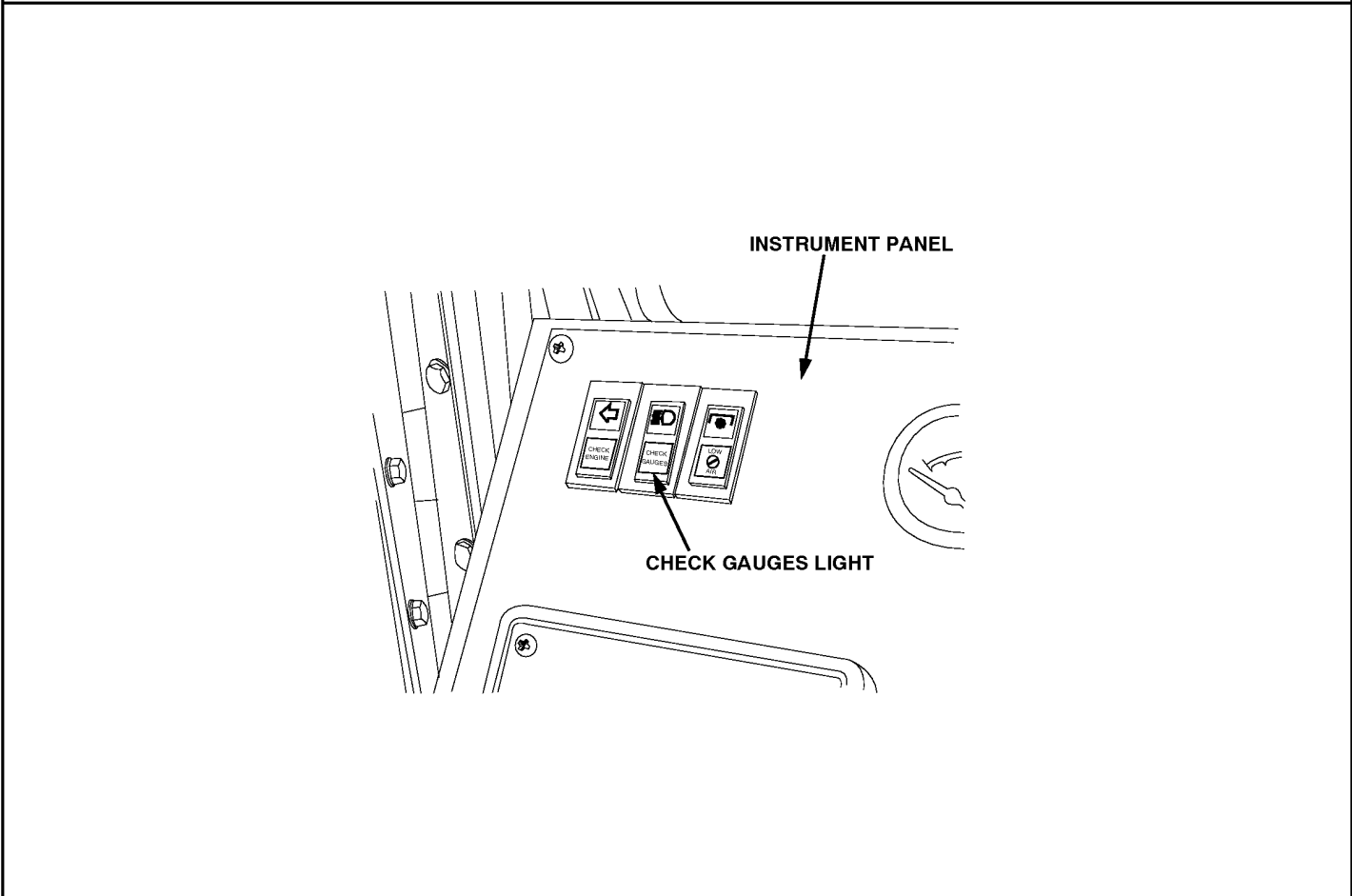
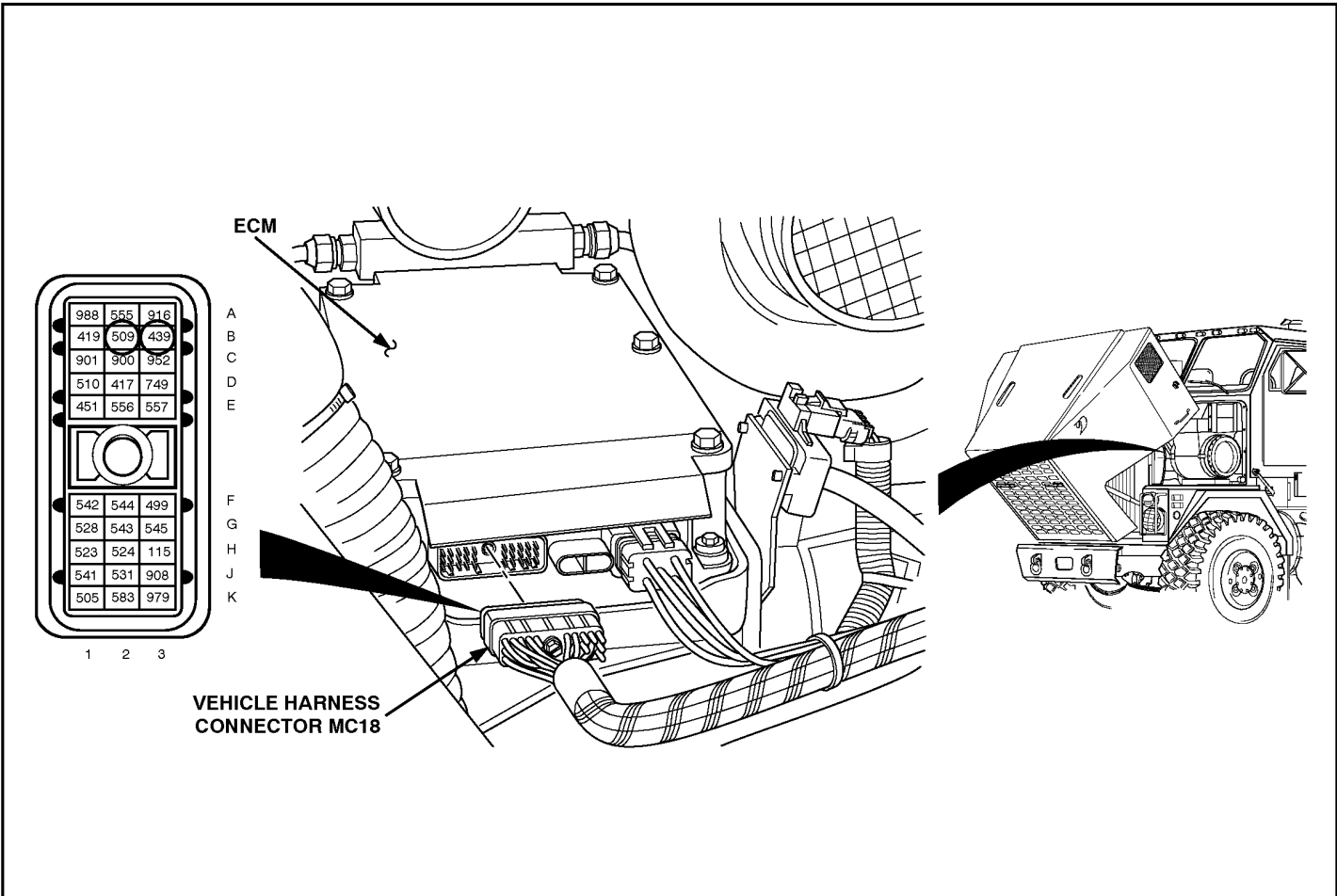

Section 4 TROUBLESHOOTING CHARTS

D. CHART -16 - "CHECK GAUGES" LIGHT ON AND NO ACTIVE CODE ON DDR

NOTE - This chart is only to be used if:

- 1) All basic mechanical checks and physical inspections have been performed with no problem found, and
- 2) Diagnosis of DDEC-III/IV was started at step START-1, pg H-25 and you have now been referred here.

This is a Digital output function.

STEP/SEQUENCE	RESULT	WHAT TO DO NEXT
<p>C 6-5 Determine "Check Gauges" Light Status</p> <ul style="list-style-type: none"> • Turn ignition on (engine not running) while at the same time observing "Check Gauges" light. 	<p>"Check Gauges" light comes on for up to 5 seconds, then goes out. →</p> <p>"Check Gauges" light comes on and stays on. →</p>	<p>This is the normal operation. Unless other problems exist, return to service.</p> <p>Go to C 6-6.</p>
<p>C 6-6 Light Status - DDR</p> <ul style="list-style-type: none"> • Plug in DDR. • Select switch/light status. • Read CGL. 	<p>CGL reads on. →</p> <p>CGL reads off. →</p>	<p>Go to C 6-8.</p> <p>Go to C 6-7.</p>
<p>C 6-7 Check for Short</p> <ul style="list-style-type: none"> • Turn ignition off. • Disconnect the vehicle harness connector at ECM. • Turn ignition on (engine not running) while at same time observing "Check Gauges" light. 	<p>"Check Gauges" light comes on and stays on. →</p> <p>"Check Gauges" light stays off. →</p>	<p>"Check Gauges" light driver line (ckt #509) is shorted to ground. Repair short. Then go to C6-30.</p> <p>Go to C 6-8.</p>
<p>C 6-8 Check ECM Connectors</p> <ul style="list-style-type: none"> • Check terminals at vehicle harness connector (both ECM and harness side) for damage bent, corroded, and unseated pins or sockets. Pay close attention to B2 and B3. 	<p>Terminals and connectors are okay. →</p> <p>Problem found. →</p>	<p>Replace ECM (para 7-29.1). Then go to C6-30.</p> <p>Repair terminals/connectors (para 7-77). Then go to C6-30.</p>

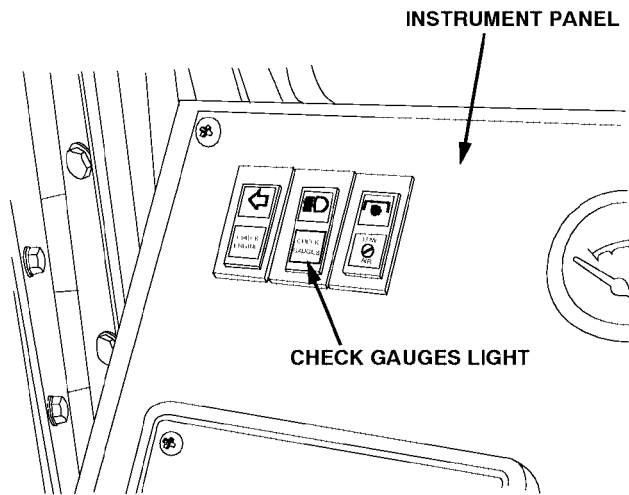

Section 4 TROUBLESHOOTING CHARTS

D. CHART -16 - "CHECK GAUGES" LIGHT ON AND NO ACTIVE CODE ON DDR (Cont'd)

STEP/SEQUENCE	RESULT	WHAT TO DO NEXT
C 6-30 Verify Repairs		
<ul style="list-style-type: none"> • Turn ignition off. • Reconnect all connectors. • Turn ignition on. • Clear codes. • Turn ignition off. • Turn ignition on while at same time observing "Check Gauges" light. 	<p>"Check Gauges" light comes on for up to 5 seconds then goes out.</p> <p>"Check Gauges" light come on and stays on.</p>	<p>Repairs are complete.</p> <p>All system diagnostics are complete. Please review this section from the first step to find error.</p>

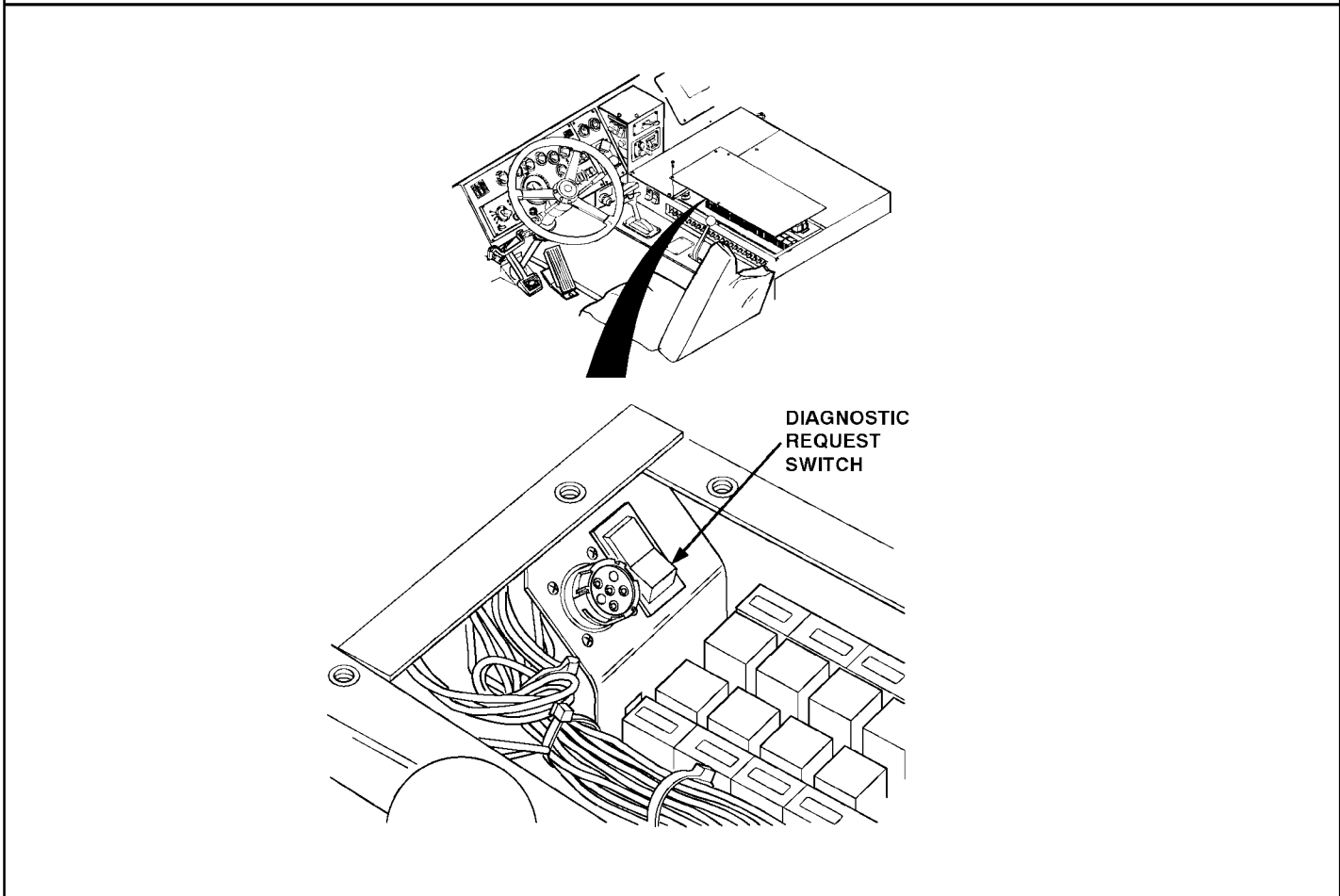
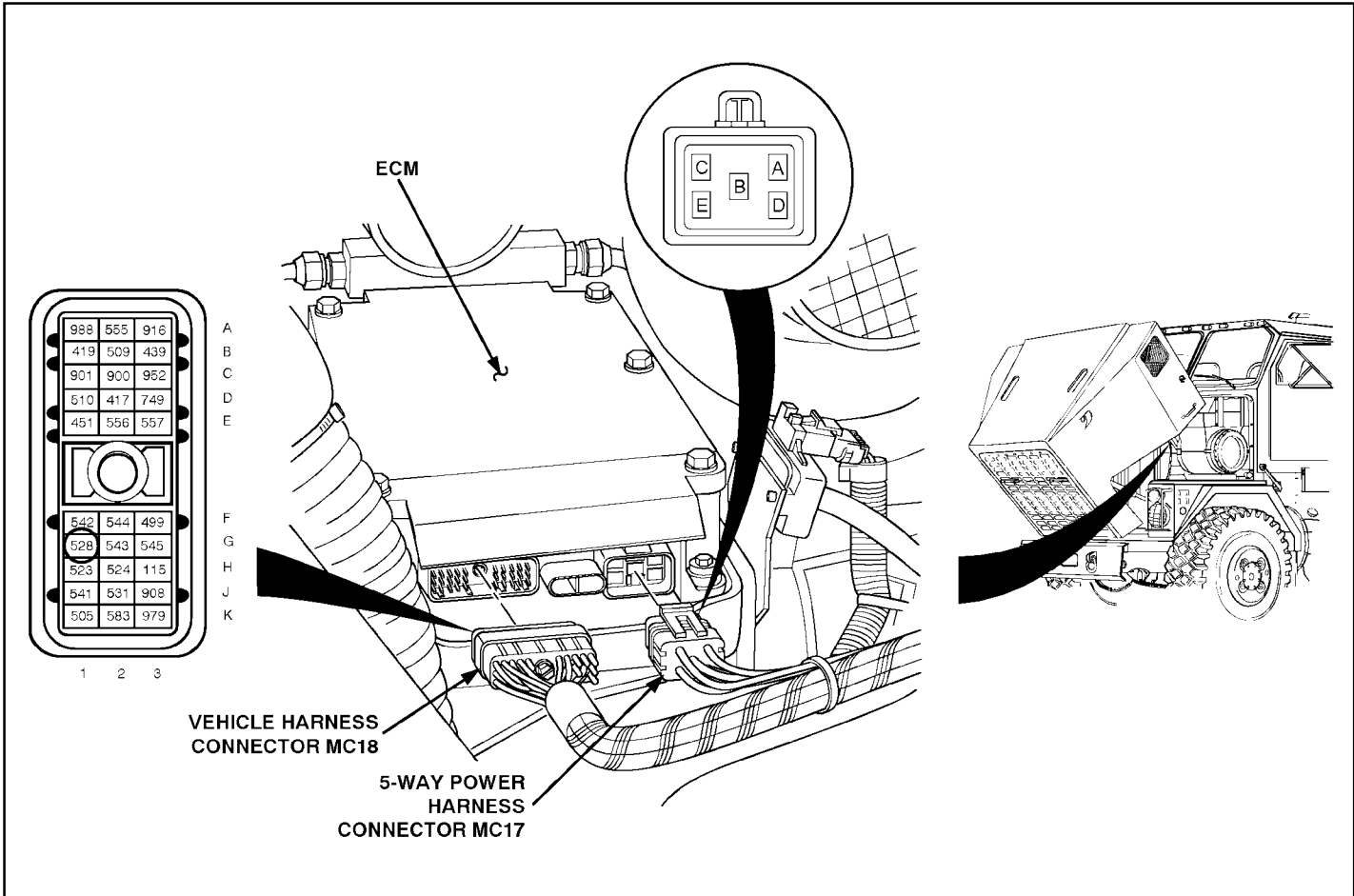

Section 4 TROUBLESHOOTING CHARTS

D. CHART -17 - NO DATA TO DDR

NOTE - This chart is only to be used if:

- 1) All basic mechanical checks and physical inspections have been performed with no problem found, and
- 2) Diagnosis of DDEC-III/IV was started at step START-1, pg H-25 and you have now been referred here.

STEP/SEQUENCE	RESULT	WHAT TO DO NEXT
<p>C 7-8 Read Codes on the “Check Engine” Light</p> <ul style="list-style-type: none"> • Unplug DDR. to • Ignition on. Engine not running. • Depress and hold diagnostic request switch. • Read codes flashing out on “Check Engine” light. 	<p>Flashes out codes. →</p> <p>Does not flash out codes. →</p>	<p>Go to C 7-11 (NOTE: if you wish bypass diagnosis of a potential data line of DDR problem for now, go to CEL-3, page H-35).</p> <p>Go to C 7-9.</p>
<p>C 7-9 Check Diagnostic Request Circuit</p> <ul style="list-style-type: none"> • Ignition on. • Plug in DDR. • Select VIEW CALIBRATION. • Select ECM INs/OUTs to determine port assigned to “Diagnostic Request” (i.e., G1 - #528) • Go to SWITCH LIGHT STATS. • Depress and hold diagnostic request switch. • Read status of diagnostic request. 	<p>Switch reads off. →</p> <p>Switch reads on. →</p>	<p>The diagnostic request circuit (#528) is open or ground is poor or open. Repair open wire or bad ground. Then go to C7-30.</p> <p>Go to C 7-10.</p>
<p>C 7-10 Check ECM Connectors</p> <ul style="list-style-type: none"> • Check terminals at vehicle harness and 5-way power harness connectors (both ECM and harness side) for damage; bent, corroded, and unseated pins or sockets. 	<p>Terminals and connectors are okay. →</p> <p>Problem found. →</p>	<p>Replace ECM (para 7-29.1). Then go to C7-30.</p> <p>Repair terminals/connectors (para 7-77). Then go to C7-30.</p>

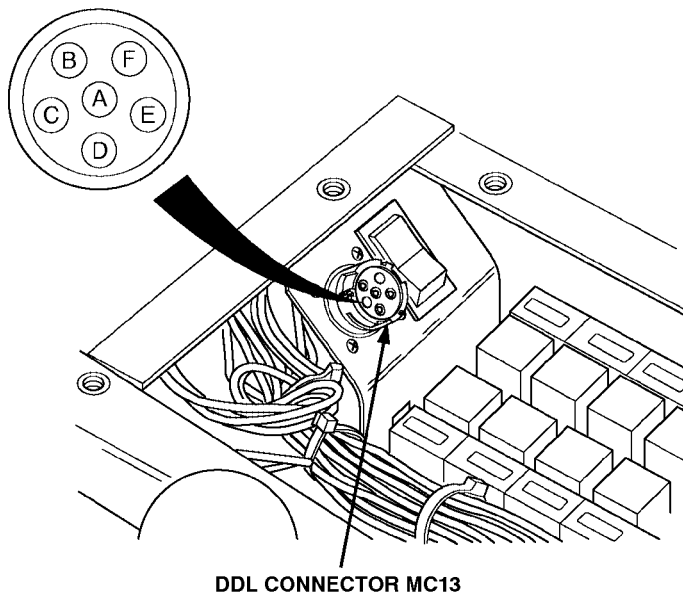
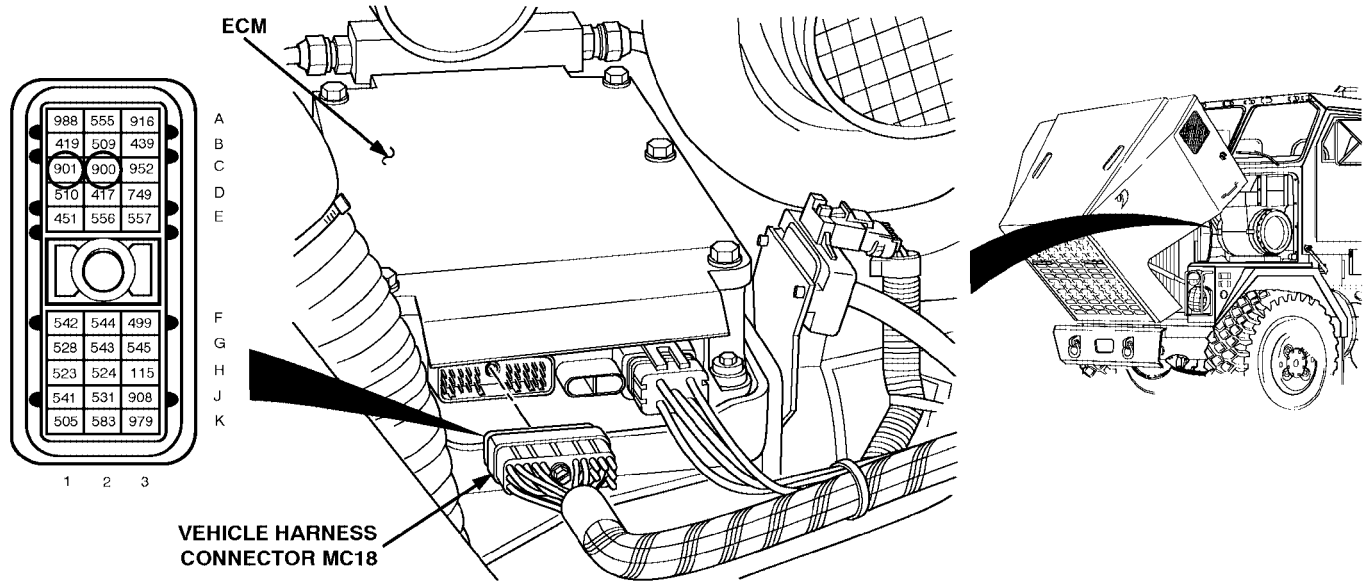

Section 4 TROUBLESHOOTING CHARTS

D. CHART -17 - NO DATA TO DDR (Cont'd)

STEP/SEQUENCE	RESULT	WHAT TO DO NEXT
<p>C 7-11 Check for Open Light</p> <ul style="list-style-type: none"> • Turn off ignition. • Place a jumper wire across pins - A (#900) and B (#901) of DDL connector. • Unplug vehicle harness connector and measure resistance between sockets C1 and C2. 	<p>Greater than 5 ohms. →</p> <p>Less than 5 ohms. →</p>	<p>One or both data wires (ckt #900 or #901) is open. Repair open and go to C7-30.</p> <p>Go to C 7-12.</p>
<p>C 7-12 Check for Short</p> <ul style="list-style-type: none"> • Remove jumper wire from DDL connector. • Read resistance between sockets C1 (#901) and C2 (#900) of vehicle harness connector. 	<p>Less than 5 ohms. →</p> <p>Greater than 5 ohms. →</p>	<p>Two data wires are shorted together (ckt #900 and #901). Repair short and go to C7-30.</p> <p>Go to C 7-13.</p>
<p>C 7-13 Check for Short to Ignition and Ground</p> <ul style="list-style-type: none"> • Remove all jumpers from the DDL connector. • Measure resistance between socket A (#900) and E (ground), A (#900) and C (sw-ign), B (#901) and E (ground), and B (#901) and C (sw-ign) of DDL connector. 	<p>Less than 5 ohms on any reading. →</p> <p>Greater than 5 ohms on any reading. →</p>	<p>A short exists between a data wires and ignition or ground. Repair short and go to C7-30.</p> <p>Go to C 7-14.</p>
<p>C 7-14 Check DDR on Another Engine</p> <ul style="list-style-type: none"> • Connect DDR to another engine and read any parameter in menu. 	<p>Works okay. →</p> <p>Does not work. →</p>	<p>Go to C7-30.</p> <p>DDR is probably defective. See DDR instruction manual for repair.</p>

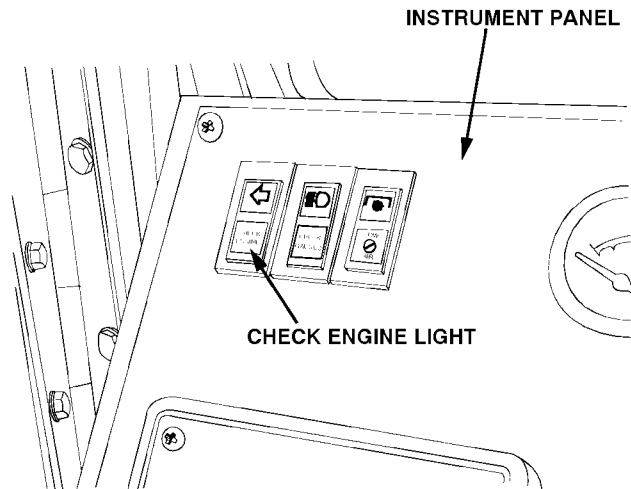

Section 4 TROUBLESHOOTING CHARTS

D. CHART -17 - NO DATA TO DDR (Cont'd)

STEP/SEQUENCE	RESULT	WHAT TO DO NEXT
C 7-30 Verify Repairs		
<ul style="list-style-type: none"> • Turn ignition off. • Reconnect all connectors. • Turn ignition on. • Clear codes. • Turn ignition off. • Turn ignition on. • Note status of "Check Engine" light. • If "Check Engine" light does not stay on, start engine and run (TM 9-2320-360-10) for 1 minute or until "Check Engine" light comes on. Stop engine. • Read inactive codes. 	DDR display reads "NO DATA BEING RECEIVED FROM SYSTEM" or "DDEC SYSTEM NOT RESPONDING".	All system diagnostics are complete. Review this section from first step to find error.
	Engine starts and DDR reads no codes.	Repairs are complete.
	Engine starts, and code appears.	Go to START-1, pg H-25, to service codes.

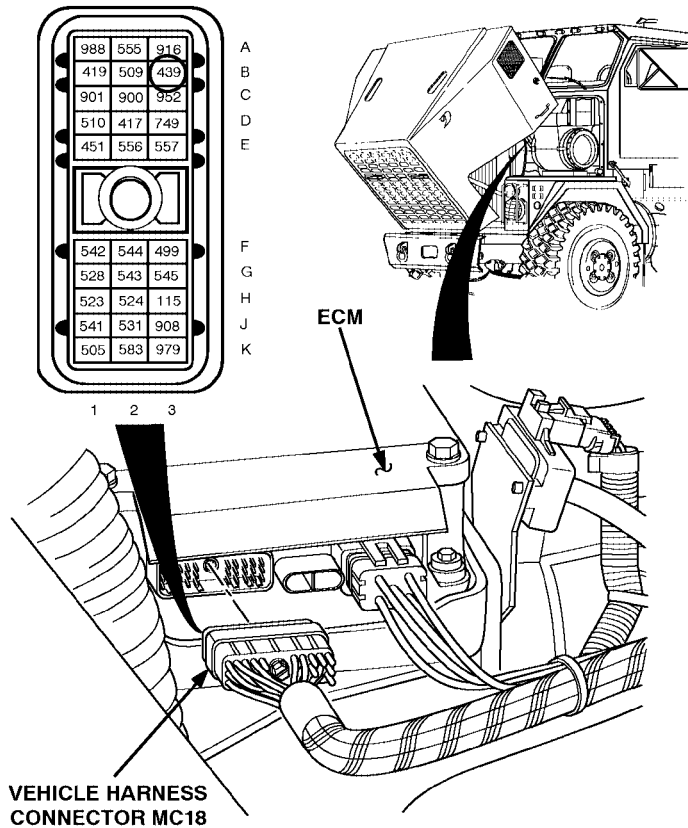
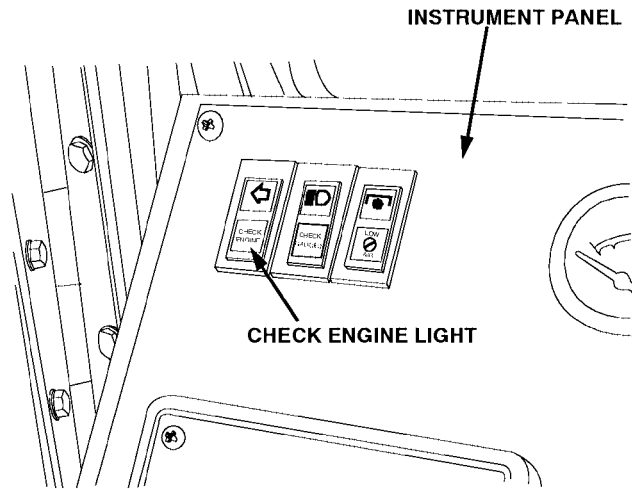

Section 4 TROUBLESHOOTING CHARTS

D. CHART -18 - NO "CHECK GAUGES" LIGHT (CGL) DURING BULB CHECK

NOTE - This chart is only to be used if:

- 1) All basic mechanical checks and physical inspections have been performed with no problem found, and
- 2) Diagnosis of DDEC-III/IV was started at step START-1, pg H-25 and you have now been referred here.

STEP/SEQUENCE	RESULT	WHAT TO DO NEXT
<p>C 8-8 Try to Force CGL on</p> <hr/> <ul style="list-style-type: none"> • Plug in DDR. • Turn ignition on. • Select activate outputs • Activate CGL with DDR. 	<p>CGL is still off. _____ →</p> <p>CGL is on. _____ →</p>	<p>Go to C 8-9</p> <p>Go to C 8-11.</p>
<p>C 8-9 Check for Short</p> <hr/> <ul style="list-style-type: none"> • Remove jumper wire. • Read voltage on vehicle harness connector, socket B3 (red lead) to a good ground (black lead). 	<p>Less than 11.5 volts. _____ →</p> <p>Greater than or equal to 11.5 volts. _____ →</p>	<p>DDEC ignition circuit breaker (CB11) is blown, and/or ignition line (ckt #439) is open or shorted to ground. Repair problem. Then go to C8-30.</p> <p>Go to C 8-10.</p>
<p>C 8-10 Bulb Check</p> <hr/> <ul style="list-style-type: none"> • Remove CGL bulb and check whether it's burned out or otherwise damaged. 	<p>Bulb is okay. _____ →</p> <p>Bulb is not okay. _____ →</p>	<p>CGL Driver line (ckt #509) is open. Repair open. Then go to C8-30.</p> <p>Replace bulb (para 7-40). Then go to C8-30.</p>

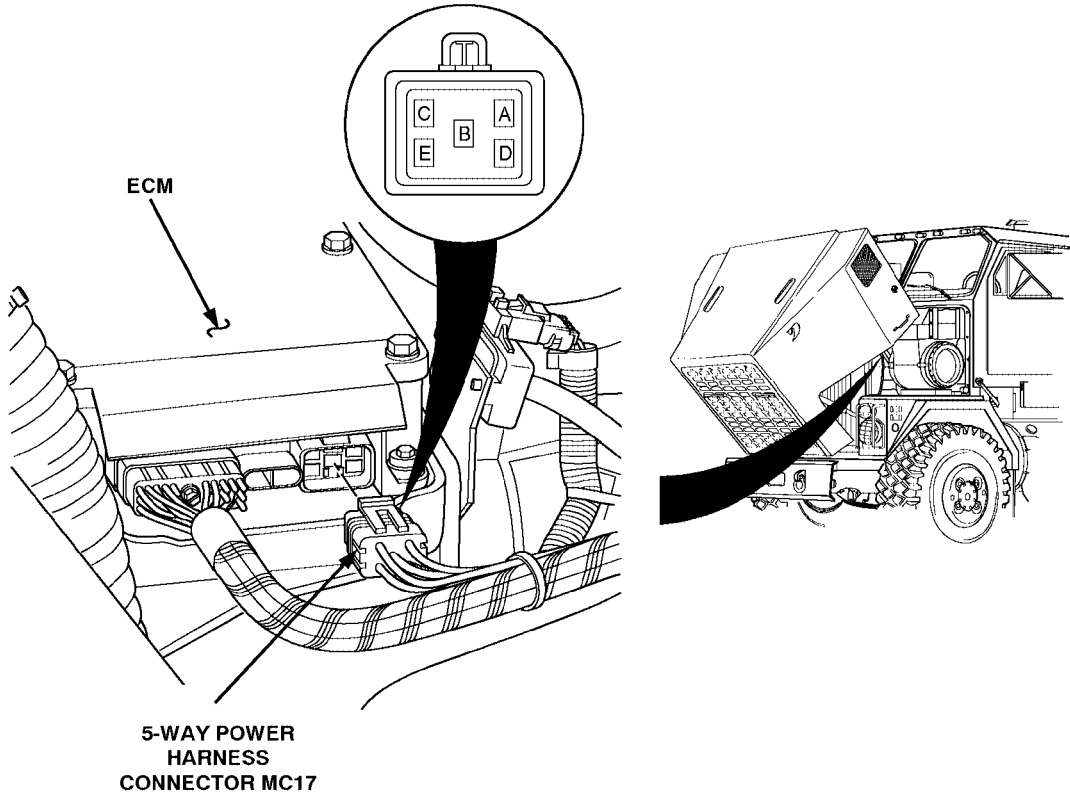
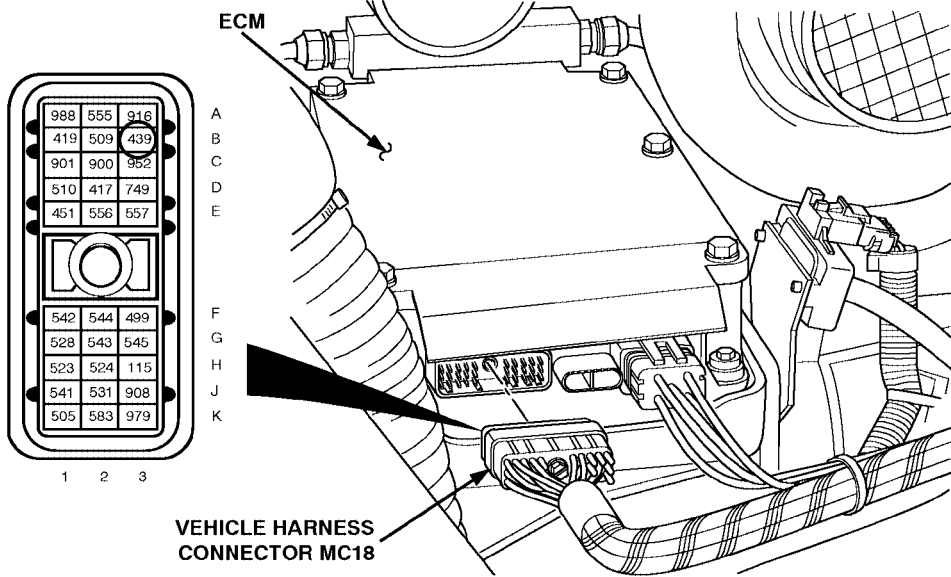

Section 4 TROUBLESHOOTING CHARTS

D. CHART -18 - NO "CHECK GAUGES" LIGHT (CGL) DURING BULB CHECK (Cont'd)

STEP/SEQUENCE	RESULT	WHAT TO DO NEXT
<p>C 8-11 Check for Open</p> <hr/> <ul style="list-style-type: none"> • Remove jumper wire. • Read voltage on vehicle harness connector, socket B3 (red lead) to a good ground (black lead). 	<p>Less than 11.5 volts. </p> <p>Greater than or equal to 11.5 volts. </p>	<p>Ignition line (ckt #439) open. Repair open. Then go to C8-30.</p> <p>Go to C 8-12.</p>
<p>C 8-12 Check for Battery +</p> <hr/> <ul style="list-style-type: none"> • Turn ignition off. • Disconnect 5-way power harness connector at ECM. • Read voltage on 5-way power harness connector, socket A (red lead), to a good ground (black lead). • Also read voltage on socket C (red lead) to a good ground (black lead). 	<p>Less than 11.5 volts on either reading. </p> <p>Greater than or equal to 11.5 volts on both readings. </p>	<p>Either a DDEC circuit breaker (CB20 or 21) is blown, and/or battery power line(s) (ckt #240 or #241) has an open or short to ground. Repair problem. Then go to C8-30.</p> <p>Go to C 8-13.</p>
<p>C 8-13 Check for Ground</p> <hr/> <ul style="list-style-type: none"> • Read voltage on 5-way power harness connector, socket A (red lead) to socket D (black lead). • Also read voltage on 5-way power harness connector, socket C (#240) (red lead) to socket E (#150) (black lead). 	<p>Less than 11.5 volts on either reading. </p> <p>Greater than or equal to 11.5 volts on both readings. </p>	<p>Ground line(s) (ckt #150) has an open. Repair open. Then go to C8-30.</p> <p>Go to C 8-14.</p>

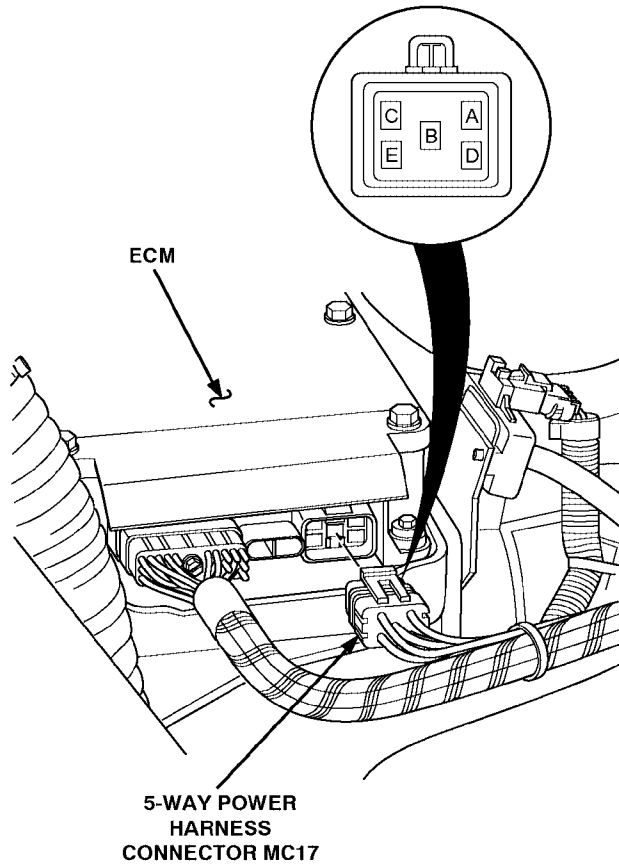
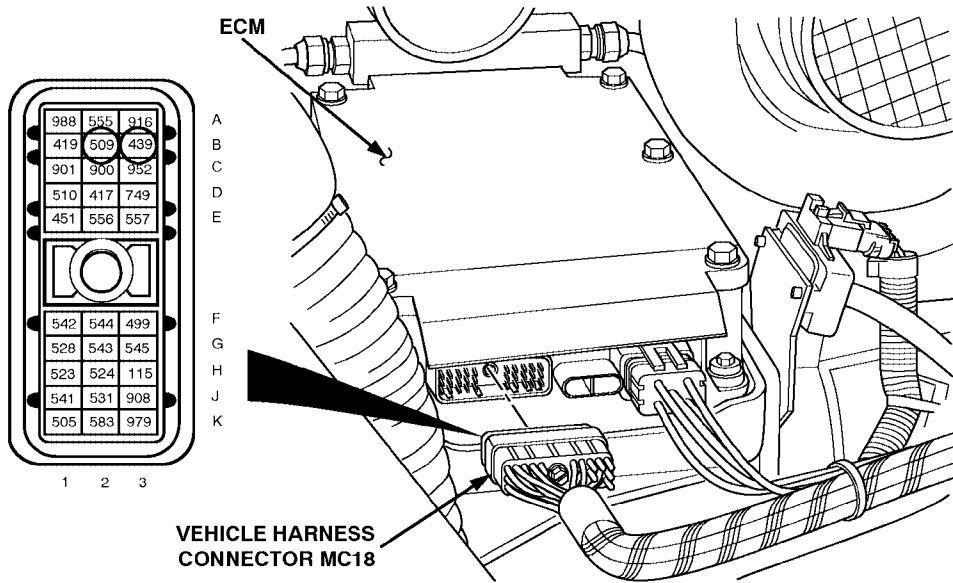

Section 4 TROUBLESHOOTING CHARTS

D. CHART -18 - NO "CHECK GAUGES" LIGHT (CGL) DURING BULB CHECK (Cont'd)

STEP/SEQUENCE	RESULT	WHAT TO DO NEXT
<p>C 8-14 Check ECM Connectors</p> <ul style="list-style-type: none"> • Check terminals at both 5-way power harness and vehicle harness connectors (both ECM and harness side) for damage; bent, corroded, and unseated pins or sockets. Pay close attention to terminals B2 and B3 of vehicle harness connector and D and E power harness. 	<p>Terminals and connectors are okay. →</p> <p>Problem found. →</p>	<p>Replace ECM (para 7-29.1). Then go to C8-30.</p> <p>Repair terminals/connectors (para 7-77). Then go to C8-30.</p>
<p>C 8-30 Verify Repairs</p> <ul style="list-style-type: none"> • Turn ignition off. • Reconnect all connectors. • Turn ignition on. • Clear codes. • Turn ignition off. • Turn ignition on while at same time observing "Check Gauges" light. 	<p>"Check Gauges" light comes on for up to 5 seconds then goes out. →</p> <p>"Check Gauges" light come on and stays on. →</p>	<p>Repairs are complete.</p> <p>All system diagnostics are complete. Please review this section from the first step to find error.</p>

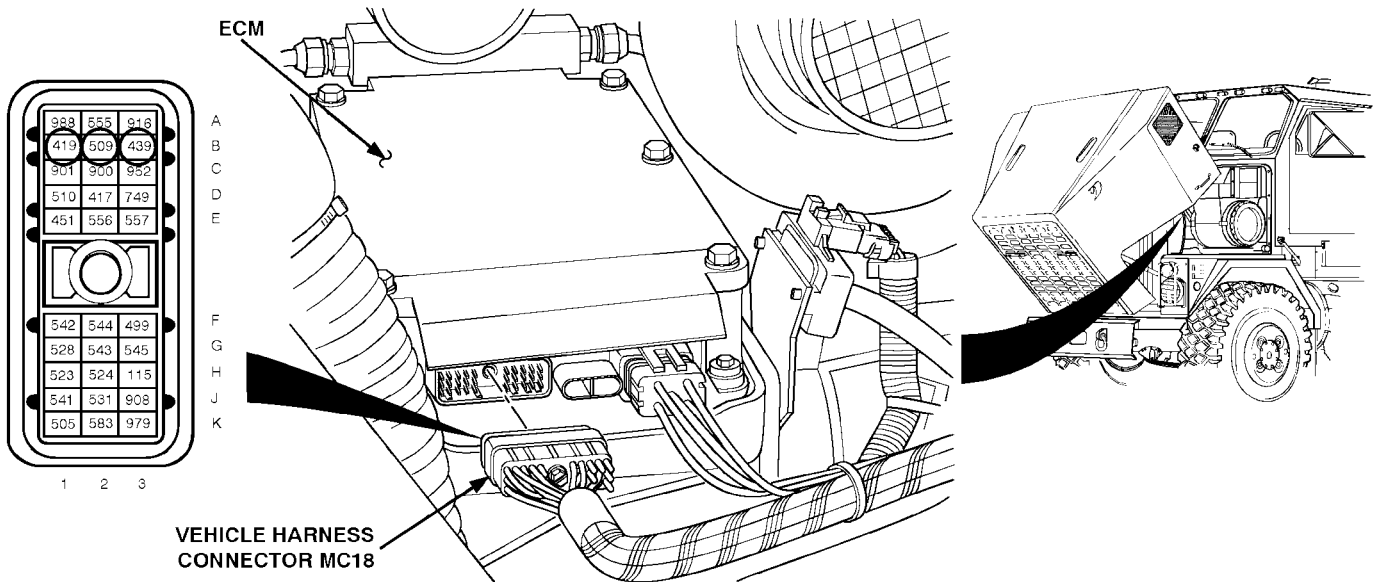
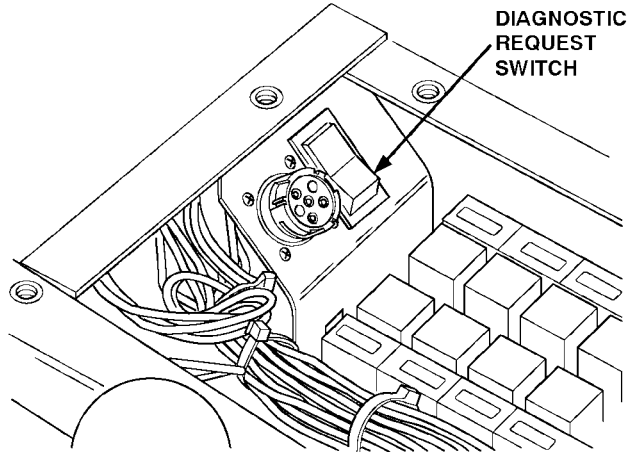
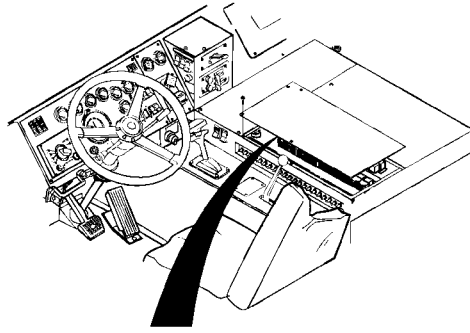

Section 4 TROUBLESHOOTING CHARTS

D. CHART -19 - DIAGNOSTIC REQUEST SWITCH INOPERATIVE

NOTE - This chart is only to be used if:

- 1) All basic mechanical checks and physical inspections have been performed with no problem found, and
- 2) Diagnosis of DDEC-III/IV was started at step START-1, pg H-25 and you have now been referred here.

STEP/SEQUENCE	RESULT	WHAT TO DO NEXT
<p>C 9-4 Check Diagnostic Request Circuit</p> <ul style="list-style-type: none"> • Turn ignition on/engine not running. • Plug in DDR. • Select SWITCH/LIGHT STATS • Depress and hold diagnostic request switch. • Observe "Diagnostic Request" status on DDR. 	<p>Display reads "ON". →</p> <p>Display reads "OFF". →</p> <p>Display reads "N/A". →</p>	<p>Go to C 9-5.</p> <p>Diagnostic request line (#528) is open, or is not being grounded when switch is depressed. Check #528 wire and ground for diagnostic request switch. Repair problem then go to C9-30.</p> <p>Replace ECM (para 7-29.1).</p>
<p>C 9-5 Check SEL/CEL Bulb</p> <ul style="list-style-type: none"> • Turn ignition off. • Remove CEL and CGL Bulb, check to see if it is burned out or damaged. 	<p>Bulb is okay. →</p> <p>Bulb is not okay. →</p>	<p>Go to C 9-6.</p> <p>Replace bulb(s) (para 7-40). Then go to C9-30.</p>
<p>C 9-6 Check Ignition Line</p> <ul style="list-style-type: none"> • Turn ignition off. • Disconnect vehicle harness connector at ECM. • Read voltage at cavity B3 (#439). 	<p>Less than 11.5V. →</p> <p>Greater than 11.5V. →</p>	<p>DDEC ignition circuit breaker (CB11) is blown and/or ignition line is open or shorted to ground.</p> <p>Ckt #419 or #509 is open. Repair open and go to C9-30.</p>

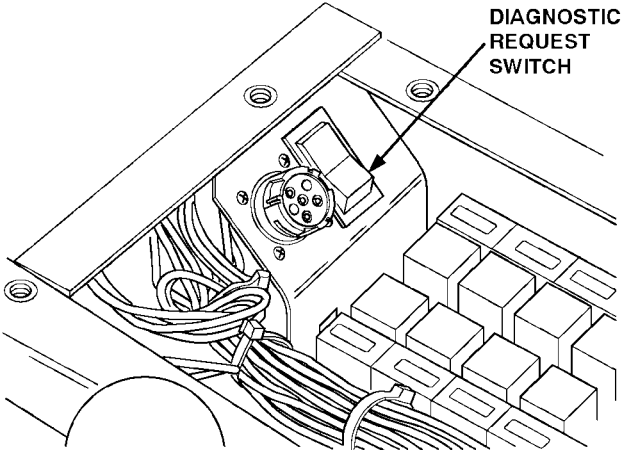

Section 4 TROUBLESHOOTING CHARTS

D. CHART -19 - DIAGNOSTIC REQUEST SWITCH INOPERATIVE (Cont'd)

STEP/SEQUENCE	RESULT	WHAT TO DO NEXT
<p>C 9-30 Verify Repairs</p>		
<ul style="list-style-type: none"> • Reconnect all connectors. • Turn ignition on. • Depress and hold diagnostic request switch. 	<p>Flashes codes (works) →</p> <p>Does not function. →</p>	<p>Repairs are complete. if any other problems exists. Go to START-1, pg H-25.</p> <p>All system diagnostics are complete. Please review this section to find error.</p>

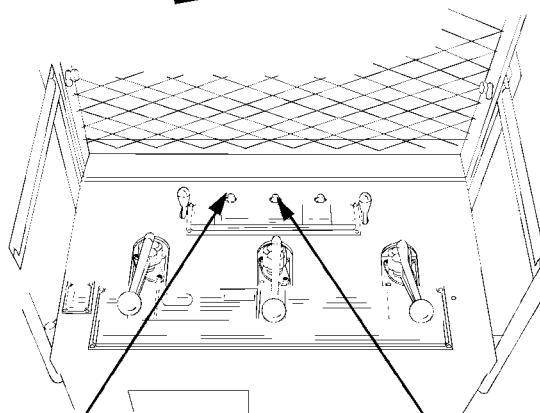
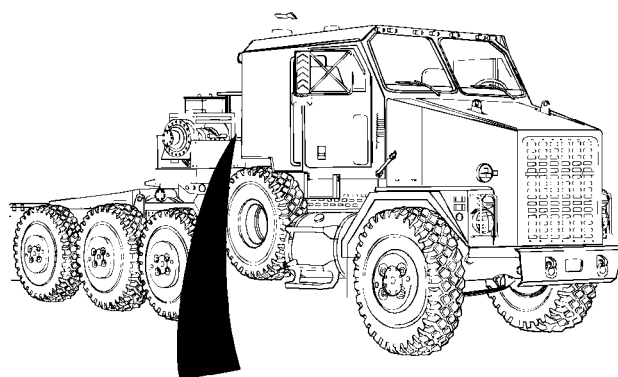

LEFT ENGINE SPEED CONTROL SWITCH

PUSH TO LOCK ENGINE @ HIGH IDLE SWITCH

Section 4 TROUBLESHOOTING CHARTS

D. CHART -20 - VARIABLE SPEED GOVERNOR (VSG OR PTO HIGH IDLE) INOPERATIVE

NOTE - This chart is only to be used if:

- 1) All basic mechanical checks and physical inspections have been performed with no problem found, and
- 2) Diagnosis of DDEC-III/IV was started at step START-1, pg H-25 and you have now been referred here.

STEP/SEQUENCE	RESULT	WHAT TO DO NEXT
C 10-1 through C 10-4 (Deleted)		
<p>C 10-5 Check Throttle Position Sensor</p> <ul style="list-style-type: none"> • Turn ignition on. • Plug DDR into DDL connector. • Engine at no throttle • Read TPS PCT using DDR. 	<p>At 0% throttle. →</p> <p>Greater than 0% throttle. →</p>	<p>Go to C 10-6.</p> <p>Check throttle position sensor adjustment. Go to 21-8 (page H-139).</p>
<p>C 10-6 Check if ECM is Reading VSG Speed</p> <ul style="list-style-type: none"> • Start engine (TM 9-2320-360-10). • Position transmission range selector to N (neutral). • Select the PTO RPM on the DDR reader. • Position left ENGINE SPEED CONTROL switch to HIGH ENGINE IDLE and press PUSH TO LOCK ENGINE @ HIGH IDLE switch. Note reading on DDR. • Shut off engine (TM 9-2320-360-10). 	<p>DDR display changes smoothly from idle (typically 600 RPM) to high idle speed (1500 RPM). →</p> <p>DDR does not change at all or does not change smoothly. →</p>	<p>Go to C 10-7.</p> <p>Go to C 10-9.</p>
<p>C 10-7 Verify Complaint</p> <ul style="list-style-type: none"> • Start engine (TM 9-2320-360-10) and run at idle. • Using the DDR reader, make sure that TPS PCT is 0. • Position left ENGINE SPEED CONTROL switch to HIGH ENGINE IDLE and press PUSH TO LOCK ENGINE @ HIGH IDLE switch. Note reading on DDR and tachograph. 	<p>RPM is increasing. →</p> <p>RPM does not increase. →</p>	<p>Problem no longer exists. Go to C 1-2 for more information (page H-41).</p> <p>Go to C 10-8.</p>

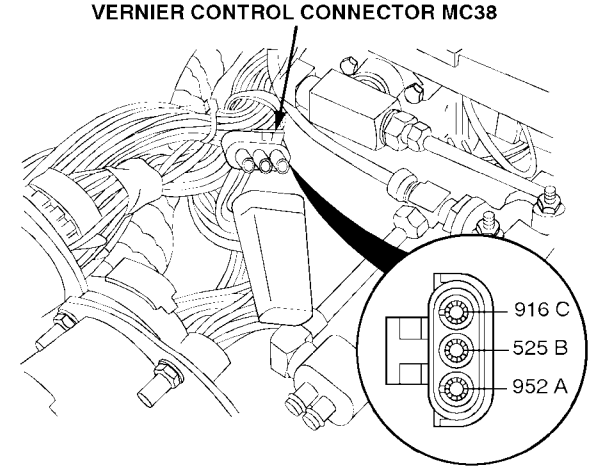
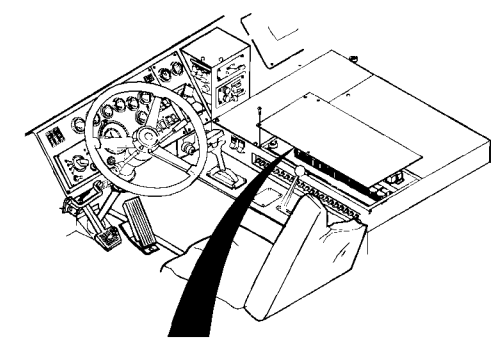
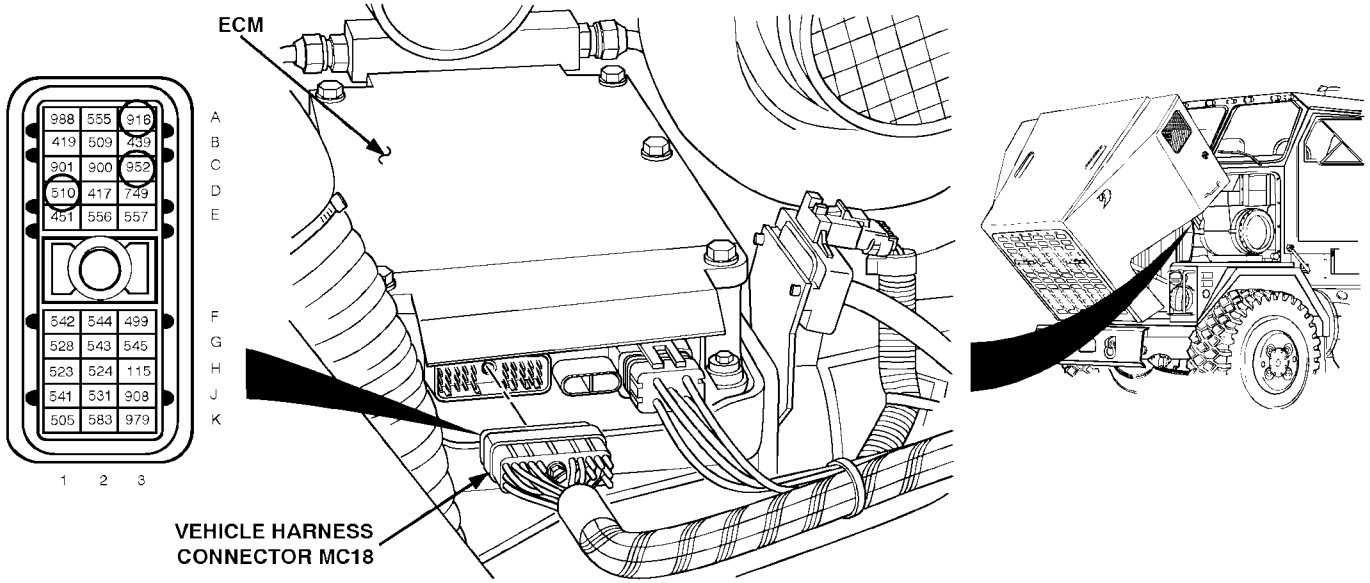

Section 4 TROUBLESHOOTING CHARTS

D. CHART -20 - VARIABLE SPEED GOVERNOR (VSG OR PTO HIGH IDLE) INOPERATIVE (Cont'd)

STEP/SEQUENCE	RESULT	WHAT TO DO NEXT
C 10-8 Check ECM Connectors		
<ul style="list-style-type: none"> • Turn ignition off. • Disconnect vehicle harness connector at ECM. • Check terminals at vehicle harness connector (both ECM and harness side) for damage; bent, corroded, and unseated pins or sockets. 	<p>Terminals and _____ → connectors are okay.</p> <p>Problem found. _____ →</p>	<p>Replace ECM (para 7-29.1). Then go to C10-30.</p> <p>Repair terminals/connectors (para 7-77). Then go to C10-30.</p>
C 10-9 Check for Open		
<ul style="list-style-type: none"> • Turn ignition off. • Make sure vehicle is in neutral. • Disconnect vehicle harness connector at ECM. • Also disconnect vernier control connector. • Install a jumper wire between pins A and B of the vernier control connector. • Read resistance between sockets D1 (#510) and C3 (#952) on vehicle harness connector. 	<p>Greater than _____ → 5 ohms or open.</p> <p>Less than or _____ → equal to 5 ohms.</p>	<p>Signal line (ckt #525 or #510). ground line (ckt #952) or the Neutral interlock switch has an open. Repair open. Then go to C10-30.</p> <p>Go to C 10-10.</p>
C 10-10 Check for +5 Volt Line Open		
<ul style="list-style-type: none"> • Move jumper so that it is now between pins C and A of vernier control connector. • Read resistance between sockets A3 (#916) and C3 (#952) on vehicle harness connector. 	<p>Greater than _____ → 5 ohms or open.</p> <p>Less than or _____ → equal to 5 ohms.</p>	<p>The +5 volt line (ckt #916) is open. Repair open. Then go to C 10-30.</p> <p>Go to C 10-11.</p>

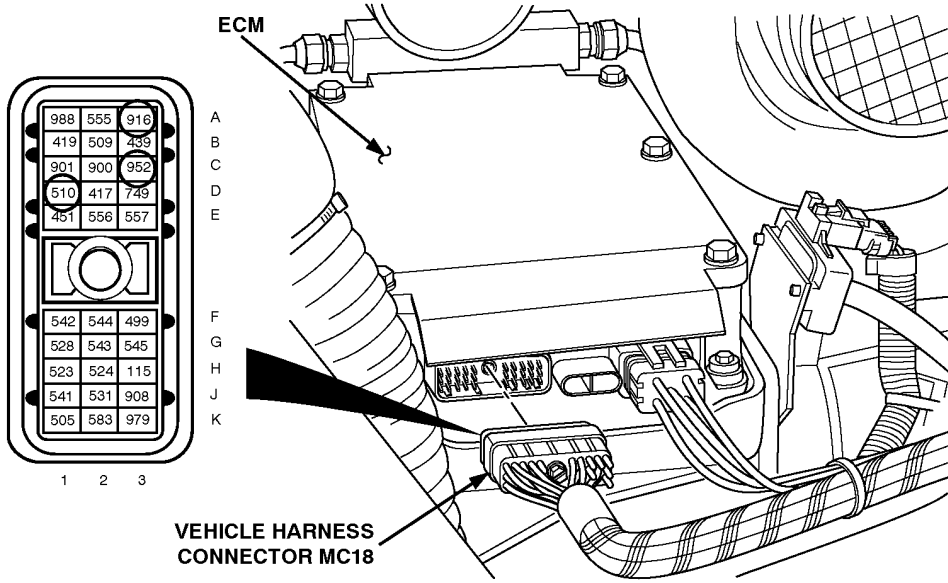

VERNIER CONTROL CONNECTOR MC38

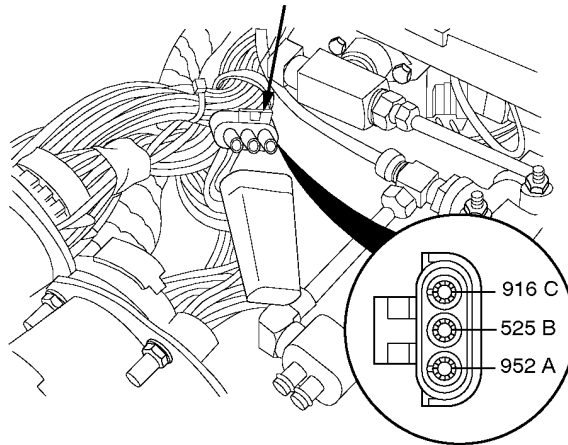

Section 4 TROUBLESHOOTING CHARTS

D. CHART -20 - VARIABLE SPEED GOVERNOR (VSG OR PTO HIGH IDLE) INOPERATIVE (Cont'd)

STEP/SEQUENCE	RESULT	WHAT TO DO NEXT
<p>C 10-11 Check for Short Between Signal and Ground</p> <ul style="list-style-type: none"> • Remove jumper wire. • Read resistance between sockets D1 (#510) and C3 (#952) on vehicle harness connector. • Also read resistance between socket D1 (#510) and a good ground. 	<p>Both readings are greater than 10,000 ohms or open.</p> <p>Either reading is less than equal to 10,000 ohms.</p>	<p>Go to C 10-12.</p> <p>Signal line (ckt #525 or #510) or neutral interlock switch is shorted to ground (either ckt #952 or chassis ground). Repair short. Then go to C10-30.</p>
<p>C 10-12 Check for Short Between +5 Volt Line and Ground</p> <ul style="list-style-type: none"> • Disconnect vernier control connector. • Read resistance between sockets A3 (#916) and C3 (#952) on vehicle harness connector. • Also read resistance between socket A3 (#916) and a good ground. 	<p>Both readings are greater than 10,000 ohms or open.</p> <p>Either reading is less than or equal to 10,000 ohms.</p>	<p>Go to C 10-13.</p> <p>The +5 volt line (ckt #916) is shorted to ground (either ckt #952 or chassis ground). Repair short. Then to to C10-30.</p>
<p>C 10-13 Check Vernier Control Connectors</p> <ul style="list-style-type: none"> • Inspect terminals at vernier control connectors (sensor side and harness side) for damaged; bent, corroded, and unseated pins or sockets. 	<p>Terminals and connectors are okay.</p> <p>Problem found.</p>	<p>Replace vernier control (para 7-76). Then go to C10-30.</p> <p>Repair terminals/connectors (para 7-77). Then go to C10-30.</p>

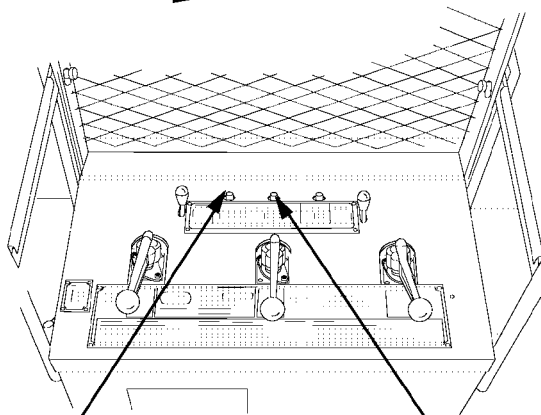
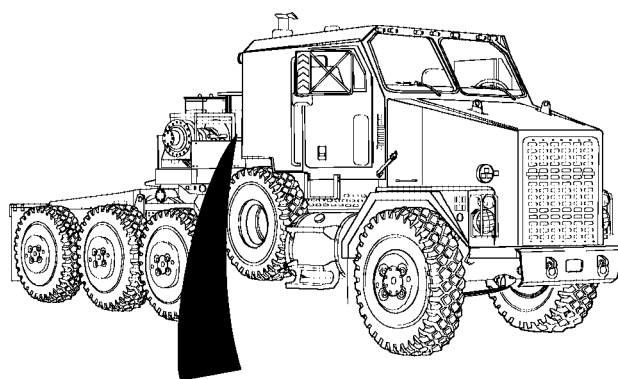

LEFT ENGINE SPEED CONTROL SWITCH

PUSH TO LOCK ENGINE @ HIGH IDLE SWITCH

Section 4 TROUBLESHOOTING CHARTS

D. CHART -20 - VARIABLE SPEED GOVERNOR (VSG OR PTO HIGH IDLE) INOPERATIVE (Cont'd)

STEP/SEQUENCE	RESULT	WHAT TO DO NEXT
<p>C 10-30 Verify Repairs</p> <ul style="list-style-type: none"> • Turn ignition off. • Reconnect all connectors. • Turn ignition on. • Clear codes. • Start engine (TM 9-2320-360-10). • Position left ENGINE SPEED CONTROL switch to HIGH ENGINE IDLE and press PUSH TO LOCK ENGINE @ HIGH IDLE switch. • Stop engine. • Read inactive codes. 	<p>PTO high idle speed still does not work. →</p> <p>PTO high idle speed works and no codes. →</p> <p>PTO high idle speed works and codes appear. →</p>	<p>All system diagnostics are complete. Please review this section from the first step to find error.</p> <p>Repairs are complete.</p> <p>Go to START-1, pg H-25, to service codes.</p>

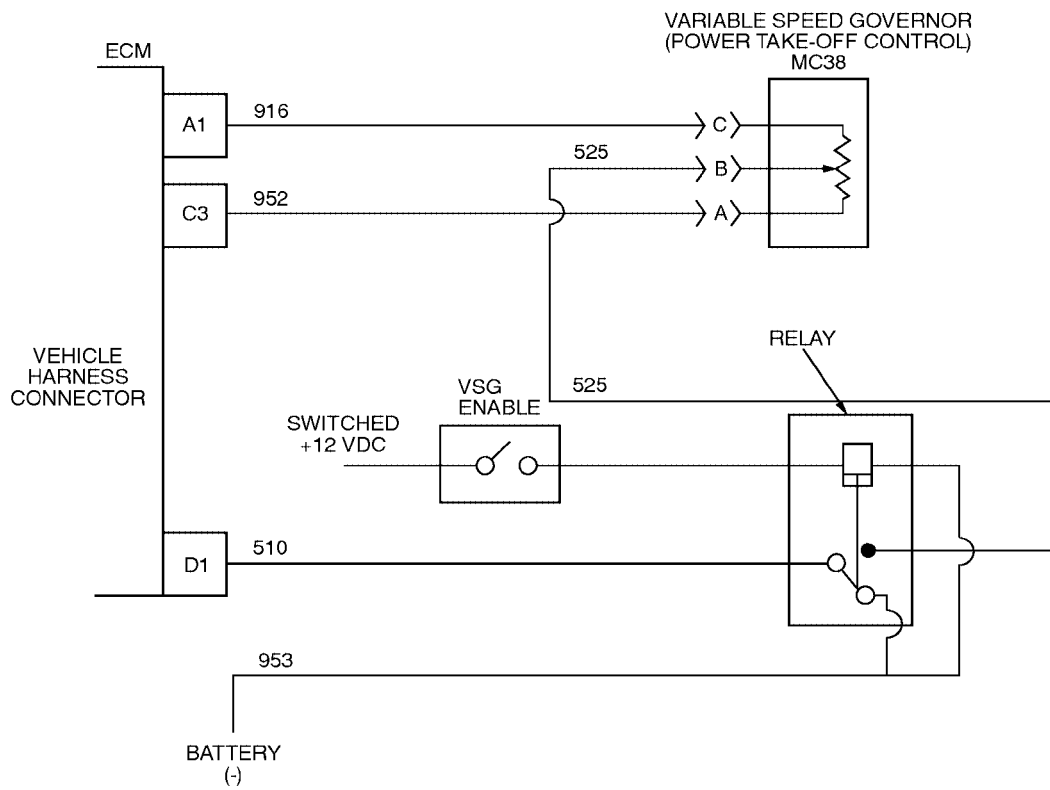
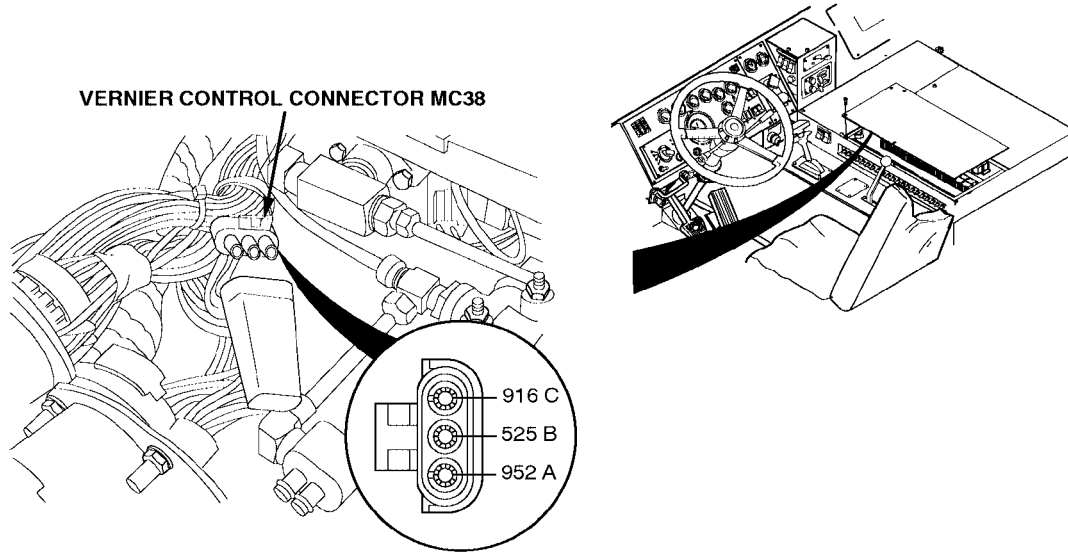

Section 4 TROUBLESHOOTING CHARTS

E. FLASH CODE: 11
J1587 CODE: P187 4 - POWER TAKE OFF INPUT FAILED LOW (VOLTAGE LOW)
(ALSO CALLED VARIABLE SPEED GOVERNOR - VSG)

NOTE - This chart is only to be used if:

- 1) All basic mechanical checks and physical inspections have been performed with no problem found, and
- 2) Diagnosis of DDEC-III/IV was started at step START-1, pg H-25 and you have now been referred here.

STEP/SEQUENCE	RESULT	WHAT TO DO NEXT
<p>11-1 Multiple Code Check</p> <ul style="list-style-type: none"> • Were there any other active codes besides 187/4? 	<p>No other active codes. → Go to 11-2.</p> <p>Yes, any or all of the following active codes: 187/3, 91/3 or 4, 100/4, 102/4, 110/4, 174/4, 175/4. → Go to VEH5V-2 , page H-247.</p> <p>Yes - but none of the above. → Go to 11-2.</p>	
<p>11-2 Sensor Check</p> <ul style="list-style-type: none"> • Turn ignition off. • Disconnect vernier control connector. • Install a jumper wire between sockets B and C of the vernier harness connector. • Turn ignition on. • Read active codes. 	<p>Code 187/3 (and/or other codes). → Go to 11-6.</p> <p>Code 187/4 (and any other codes). → Go to 11-3.</p>	
<p>11-3 Check Vernier Control Adjustment</p> <ul style="list-style-type: none"> • Remove jumper and reconnect vernier control. • Hook-up DDR to the DDL connector and select VSG CNTS. • Position left ENGINE SPEED CONTROL switch to HIGH ENGINE IDLE and press PUSH TO LOCK ENGINE @ HIGH IDLE switch. • Read counts. 	<p>Getting 48 to 968 counts. → Go to 11-5.</p> <p>Not getting the above readings. → Go to 11-4.</p>	
<p>11-4 Attempt Vernier Control Adjustment</p> <ul style="list-style-type: none"> • Replace vernier control (para 7-76). 	<p>Corrected problem so that Throttle Counts is now correct. → Go to 11-30.</p> <p>Could not correct the problem. → Go to 11-5.</p>	

VERNIER CONTROL CONNECTOR MC38

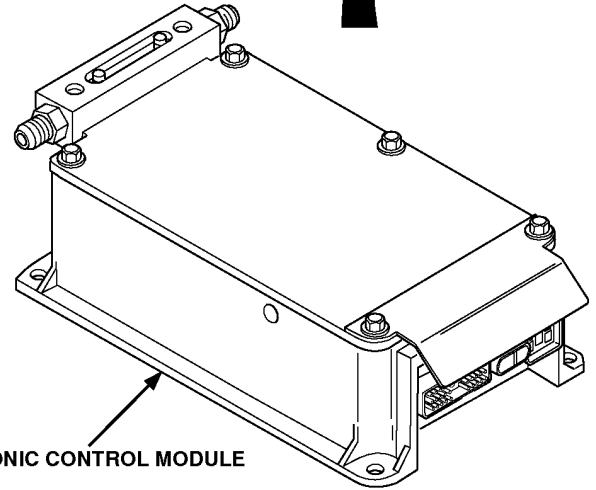
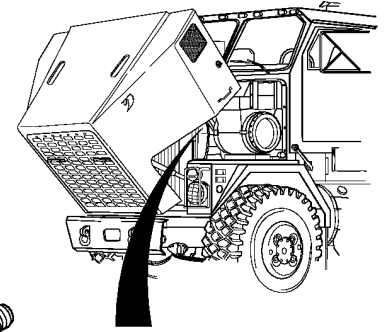
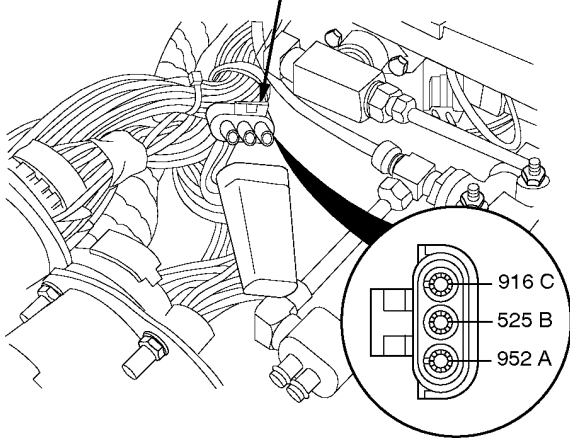

ELECTRONIC CONTROL MODULE

ECM SHOWN REMOVED FOR CLARITY

ECM

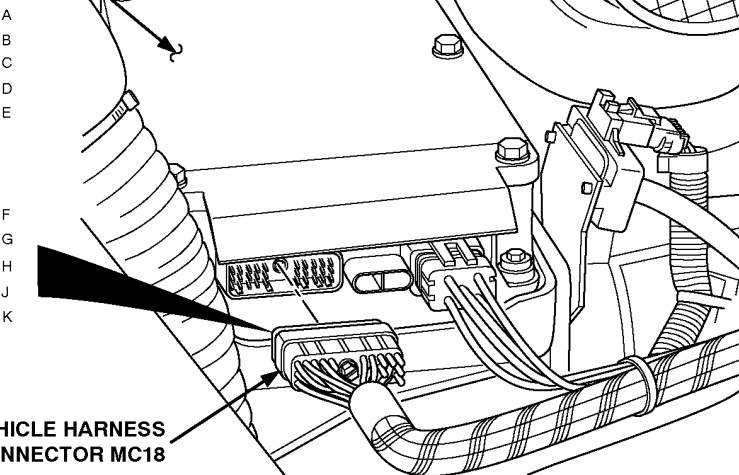
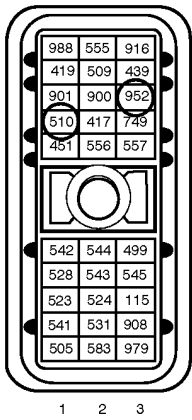

VEHICLE HARNESS CONNECTOR MC18

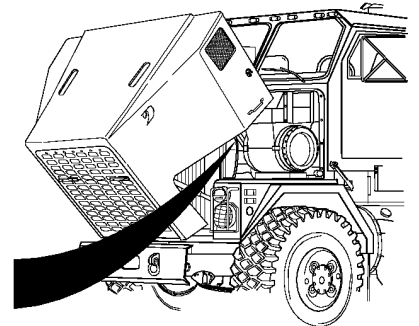

Section 4 TROUBLESHOOTING CHARTS

E. FLASH CODE: 11
J1587 CODE: P187 4 - POWER TAKE OFF INPUT FAILED LOW (VOLTAGE LOW)
(ALSO CALLED VARIABLE SPEED GOVERNOR - VSG)

STEP/SEQUENCE	RESULT	WHAT TO DO NEXT
<p>11-5 Check Vernier Control Connectors</p> <ul style="list-style-type: none"> Inspect terminals at the vernier control connectors (sensor side and harness side) for damage; bent, corroded, and unseated pins or sockets. 	<p>Terminals and connectors are okay. →</p> <p>Problem found. →</p>	<p>Replace vernier control (para 7-76). Then go to 11-30.</p> <p>Repair terminals/connectors (para 7-77). Then go to 11-30.</p>
<p>11-6 Check for +5 Volts</p> <ul style="list-style-type: none"> Remove jumper. Turn ignition on. Read voltage on vernier control connector, socket C (red lead) to socket A (black lead). 	<p>Between 4 to 6 volts. →</p> <p>Less than 4 volts. →</p> <p>Greater than 6 volts. →</p>	<p>Go to 11-7.</p> <p>Go to 11-10.</p> <p>Go to 11-12.</p>
<p>11-7 Check for Short</p> <ul style="list-style-type: none"> Turn ignition off. Disconnect the vehicle harness connector ECM. Read resistance between sockets A and B on the vernier control connector. 	<p>Less than or equal to 10,000 ohms. →</p> <p>Greater than 10,000 ohms or open. →</p>	<p>Signal line (ckt #525) is shorted to the return line (ckt #952). Repair short. Then go to 11-30.</p> <p>Go to 11-8.</p>
<p>11-8 Check for Signal Open</p> <ul style="list-style-type: none"> Install a jumper wire between sockets A and B of the vernier control connector. Read resistance between sockets D1 (510) & C3 (952) on the vehicle harness connector. 	<p>Less than or equal to 5 ohms. →</p> <p>Greater than 5 ohms or open. →</p>	<p>Go to 11-9.</p> <p>Signal line (ckt #510) is open, and/or signal return (ckt #952) is open. Repair open. If no open was found, check ECM terminals A3, D1, C3, and vernier control pins. Then go to 11-30.</p>

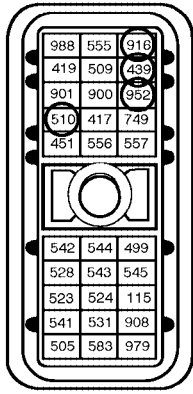

A
B
C
D
E

F
G
H
J
K

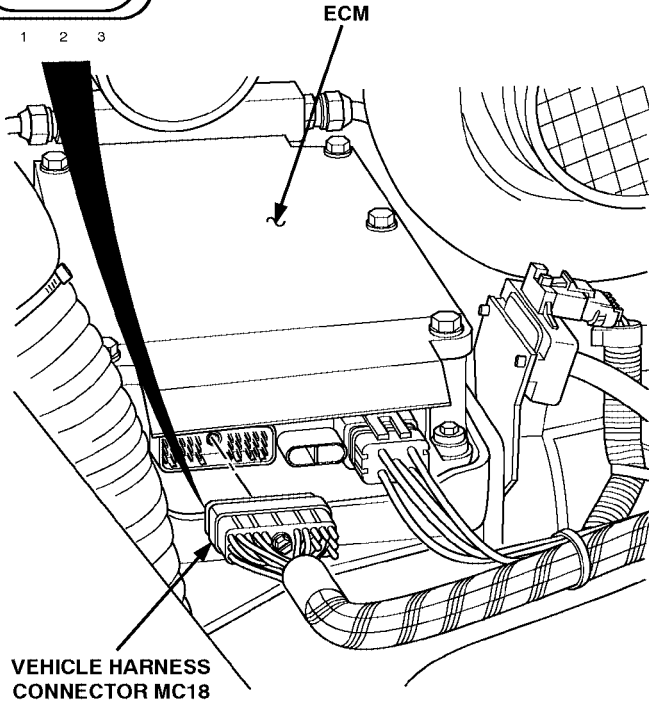

VERNIER CONTROL CONNECTOR MC38

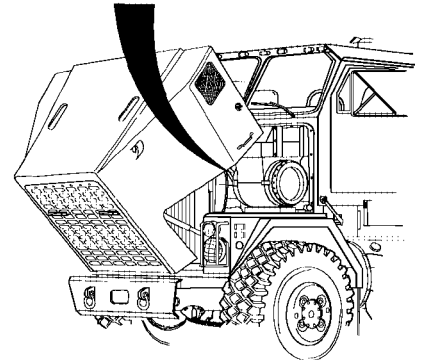
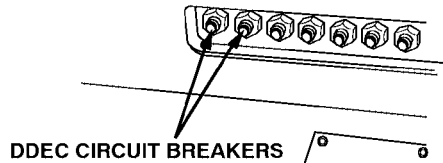
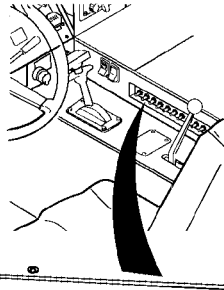
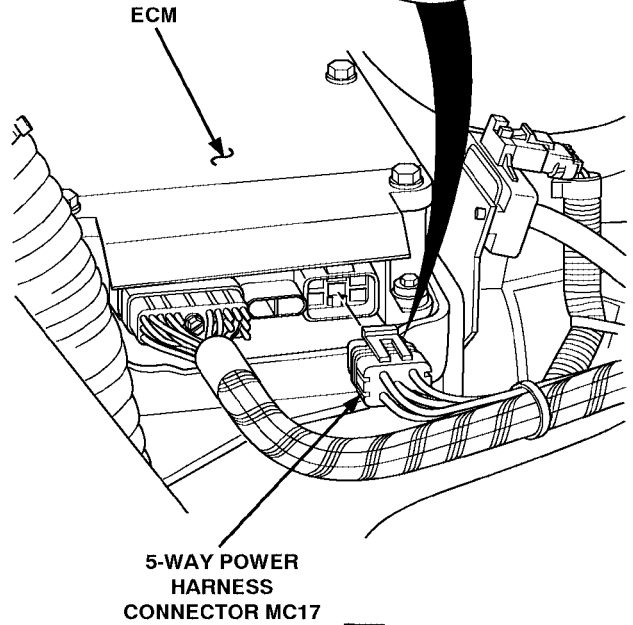
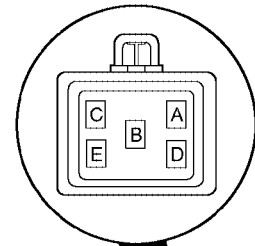
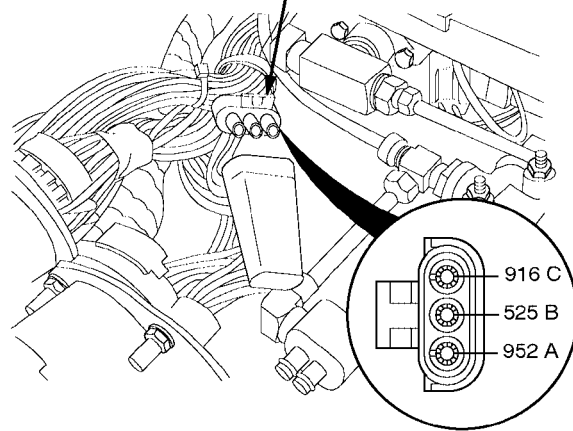

Section 4 TROUBLESHOOTING CHARTS

E. FLASH CODE: 11
J1587 CODE: P187 4 - POWER TAKE OFF INPUT FAILED LOW (VOLTAGE LOW)
(ALSO CALLED VARIABLE SPEED GOVERNOR - VSG)

STEP/SEQUENCE	RESULT	WHAT TO DO NEXT
<p>11-9 Check ECM Connectors</p> <ul style="list-style-type: none"> • Check terminals at the vehicle harness connector (both the ECM and harness side) for damage; bent, corroded, and unseated pins or sockets. 	<p>Terminals and connectors are okay. →</p> <p>Problem found. →</p>	<p>Replace ECM (para 7-29.1). Then go to 11-30.</p> <p>Repair terminals/connectors (para 7-77). Then go to 11-30.</p>
<p>11-10 Check for Short</p> <ul style="list-style-type: none"> • Turn ignition off. • Disconnect the vehicle harness connector at the ECM. • Read resistance between sockets A and C on the vernier control connector. 	<p>Less than or equal to 10,000 ohms. →</p> <p>Greater than 10,000 ohms or open. →</p>	<p>The vehicle +5 volt line (ckt #916) is shorted to the return line (ckt #952). Repair short. Then go to 11-30.</p> <p>Go to 11-11.</p>
<p>11-11 Check Check for Open +5 Volt line</p> <ul style="list-style-type: none"> • Install a jumper wire between sockets A and C of the vernier control connector. • Read resistance between sockets A3 (916) & C3 (952) on the vehicle harness connector. 	<p>Less than or equal to 5 ohms. →</p> <p>Greater than 5 ohms or open. →</p>	<p>Go to 11-9.</p> <p>The vehicle +5 volt line (ckt #916) is open. Repair open. Then go to 11-30.</p>
<p>11-12 Check for Short to Battery +</p> <ul style="list-style-type: none"> • Turn ignition off. • Disconnect batteries (para 7-61). • Disconnect 5-way power harness connector at the ECM. • Read resistance between sockets D1 (510) & B3 (439) on the vehicle harness connector. • Also read resistance between socket D1 (510) on the vehicle harness connector and the following sockets on the 5-way power harness connector: C, D, E, and B. • Connect batteries (para 7-61). 	<p>All readings are greater than 10,000 ohms or open. →</p> <p>Any reading is less than or equal to 10,000 ohms. →</p>	<p>Go to 11-13.</p> <p>A short exists between sockets where less the 10,000 ohms resistance was read. Repair short and reset circuit breakers. Then go to 11-30.</p>

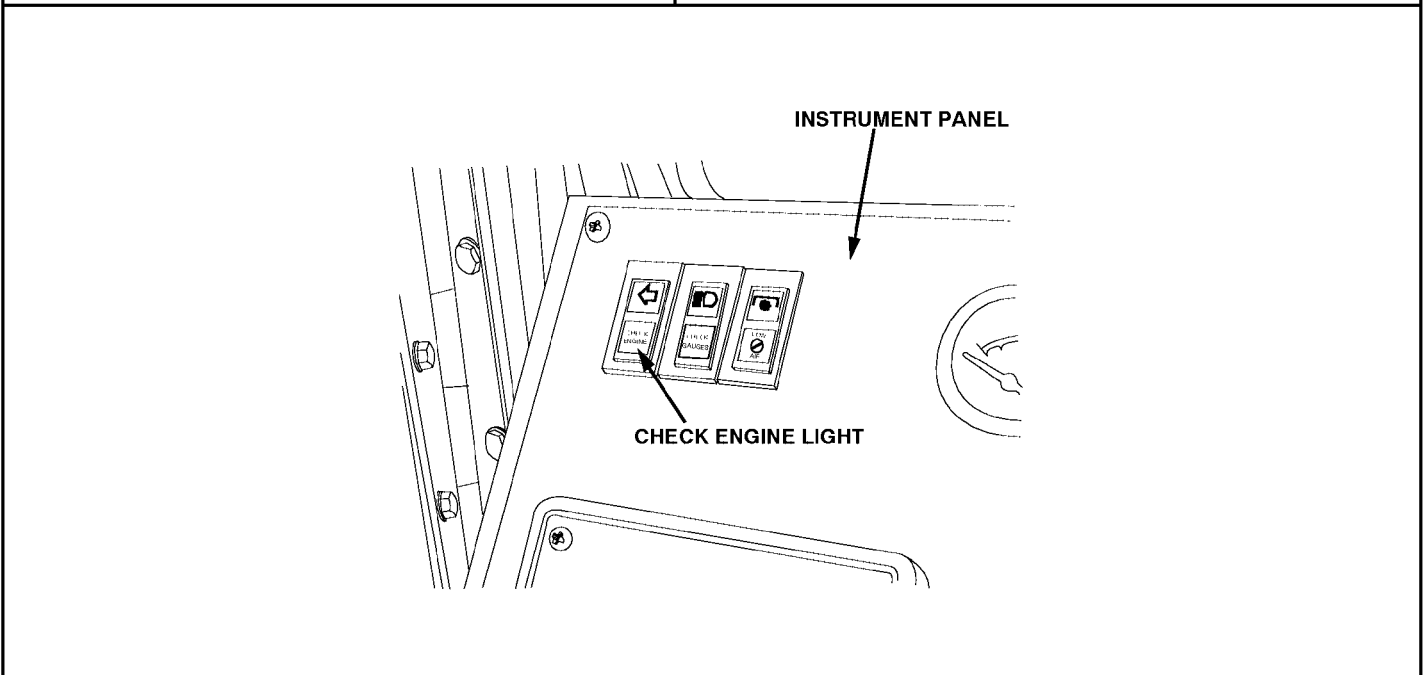
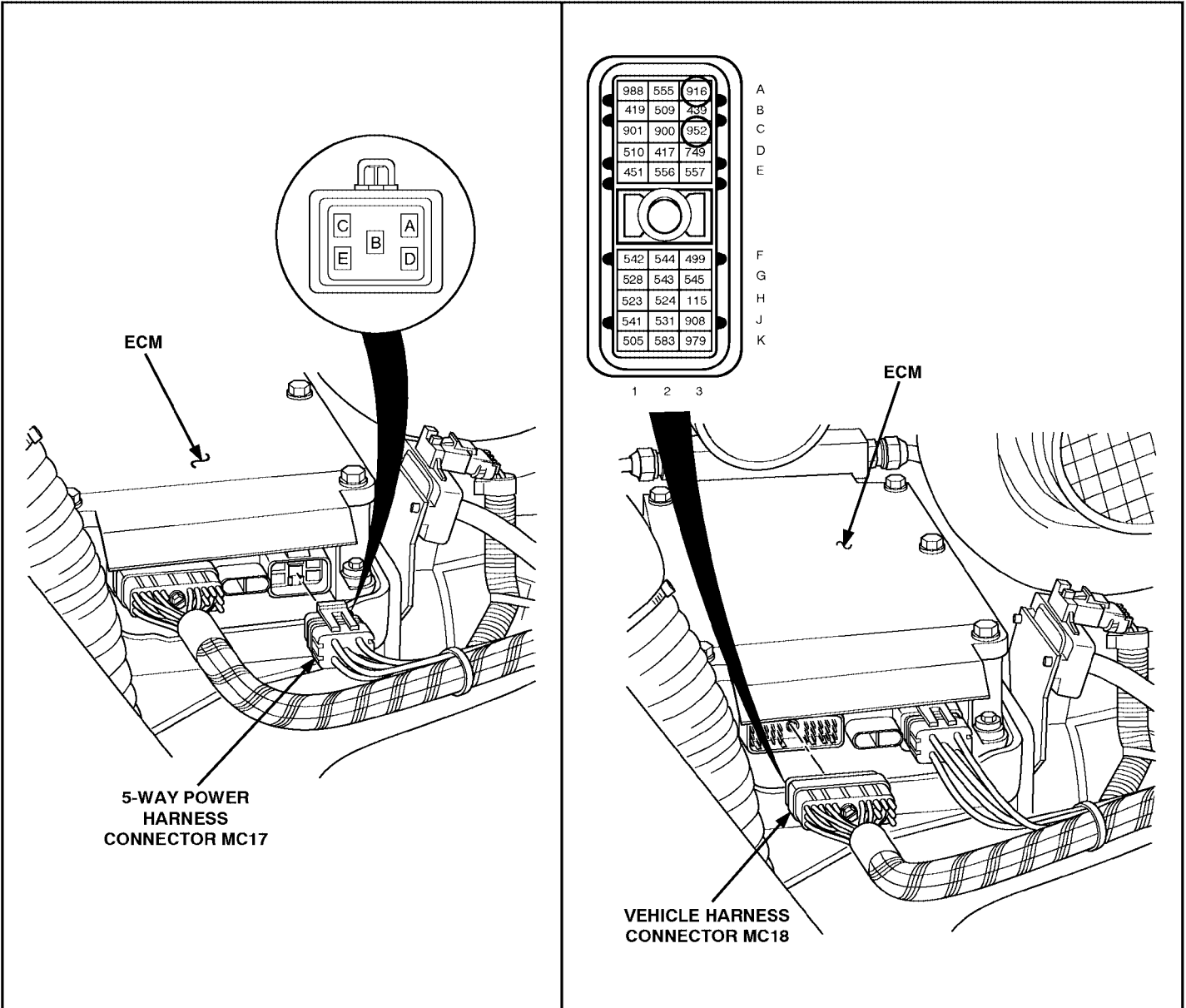

Section 4 TROUBLESHOOTING CHARTS

E. FLASH CODE: 11
J1587 CODE: P187 4 - POWER TAKE OFF INPUT FAILED LOW (VOLTAGE LOW)
(ALSO CALLED VARIABLE SPEED GOVERNOR - VSG)

STEP/SEQUENCE	RESULT	WHAT TO DO NEXT
<p>11-13 Check for Outside DDEC Battery +</p> <ul style="list-style-type: none"> • Deleted • Deleted • Deleted • Turn ignition on. • Read voltage A3 (916) to a good ground. • Read voltage C3 (952) to a good ground. 	<p>All readings less than 4.0 volts.</p> <p>Either reading greater than or equal to 4.0 volts.</p>	<p>Go to 11-9.</p> <p>Outside power is shorted to either ckt #952 or ckt #916. Repair short. Then go to 11-30.</p>
<p>11-30 Verify Repairs</p> <ul style="list-style-type: none"> • Turn ignition off. • Reconnect all connectors. • Turn ignition on. • Clear codes. • Note status of "Check Engine" light. • If "Check Engine" light does not stay on, start engine and run (TM 9-2320-360-10) until "Check Engine" light comes on or 1 minute. • Stop engine. • Read all codes. 	<p>No codes.</p> <p>Code 187/4 (and any other codes).</p> <p>Any other codes except Code 187/4.</p>	<p>Repairs are complete.</p> <p>All system diagnostics are complete. Please review this section from the first step to find the error.</p> <p>Go to START-1, pg H-25, to service other codes.</p>

VERNIER CONTROL CONNECTOR MC38

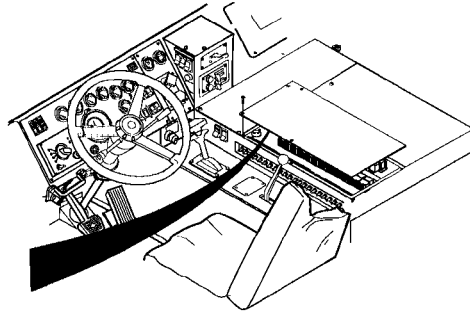
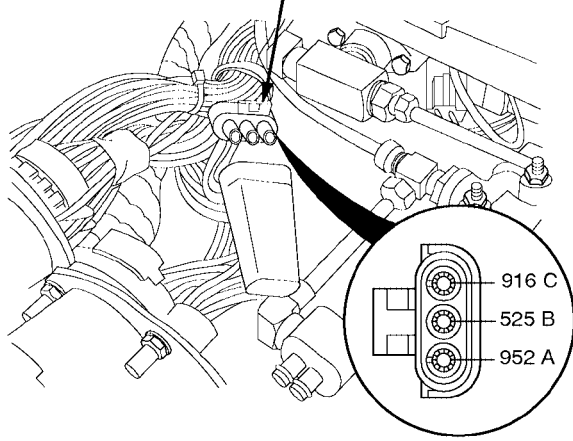

988	555	916
419	509	499
901	900	952
510	417	749
951	556	557
[Circular Connector]		
542	544	499
528	543	545
523	524	115
541	531	908
505	583	979

A
B
C
D
E

F
G
H
J
K

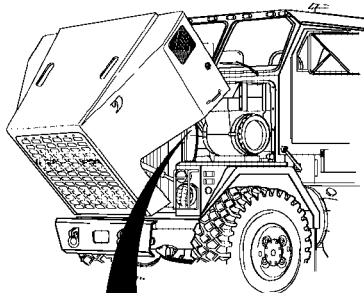

ECM

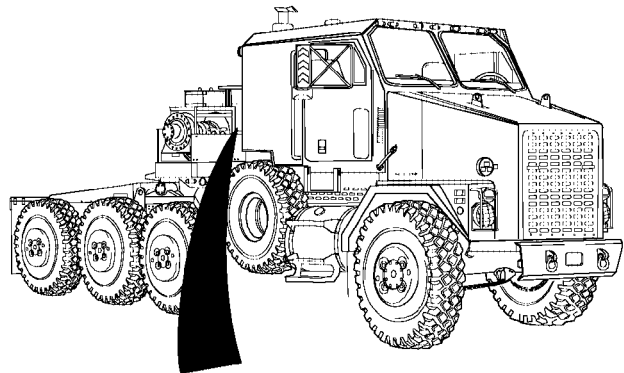

LEFT ENGINE SPEED CONTROL SWITCH

PUSH TO LOCK ENGINE @ HIGH IDLE SWITCH

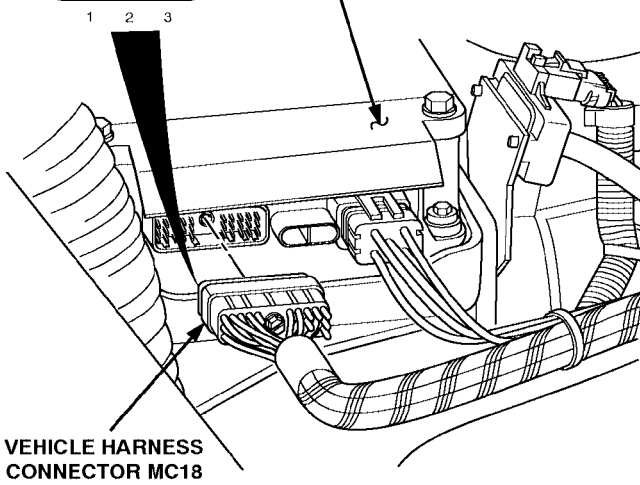
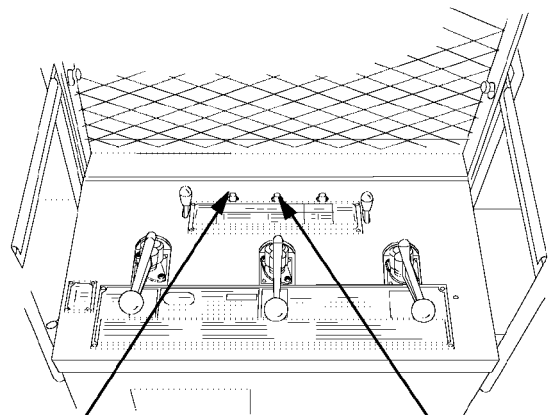

VEHICLE HARNESS CONNECTOR MC18

Section 4 TROUBLESHOOTING CHARTS

E. FLASH CODE: 12
J1587 CODE: P187 3 - POWER TAKE OFF (PTO) INPUT FAILED HIGH (HIGH VOLTAGE)
(ALSO CALLED VARIABLE SPEED GOVERNOR - VSG)

NOTE - This chart is only to be used if:

- 1) All basic mechanical checks and physical inspections have been performed with no problem found, and
- 2) Diagnosis of DDEC-III/IV was started at step START-1, pg H-25 and you have now been referred here.

STEP/SEQUENCE	RESULT	WHAT TO DO NEXT
<p>12-1 Multiple Code Check</p> <ul style="list-style-type: none"> • Were there any other active codes besides Code 187/3? 	<p>No other active codes. →</p> <p>Yes, either code 91/3 or 4. →</p> <p>Yes - but none of the above. →</p>	<p>Go to 12-2.</p> <p>Go to VEH5V-2 , page H-247.</p> <p>Go to 12-2.</p>
<p>12-2 Sensor Check</p> <ul style="list-style-type: none"> • Turn ignition off. • Unplug the vernier control connector. • Turn ignition on. • Read active codes. 	<p>Any codes except Code 187/3. →</p> <p>Code 187/3 (and any other codes). →</p>	<p>Go to 12-3.</p> <p>Go to 12-5.</p>
<p>12-3 Return Circuit Check</p> <ul style="list-style-type: none"> • Transmission in neutral. • Turn ignition off. • Install a jumper wire between pin A and pin B of the vernier control connector. • Disconnect the vehicle harness connector at the ECM. • Turn ignition on. • Position left ENGINE SPEED CONTROL switch to HIGH ENGINE IDLE and press PUSH TO LOCK ENGINE @ HIGH IDLE switch. • Read resistance between sockets C3 (952) and D1 (510) on the vehicle harness connector. 	<p>Less than or equal to 5 ohms. →</p> <p>Greater than 5 ohms or open. →</p>	<p>Go to 12-4.</p> <p>Return line (ckt #952) is open. Repair open. Then go to 12-30.</p>
<p>12-4 Check Vernier Control Connectors</p> <ul style="list-style-type: none"> • Inspect terminals at the vernier control connectors (sensor side and harness side) for damage; bent, corroded, and unseated pins or sockets. 	<p>Terminals and connectors are okay. →</p> <p>Problem found. →</p>	<p>Replace vernier control (para 7-76). Then go to 12-30.</p> <p>Repair terminals/connectors (para 7-77). Then go to 12-30.</p>

VERNIER CONTROL CONNECTOR MC38

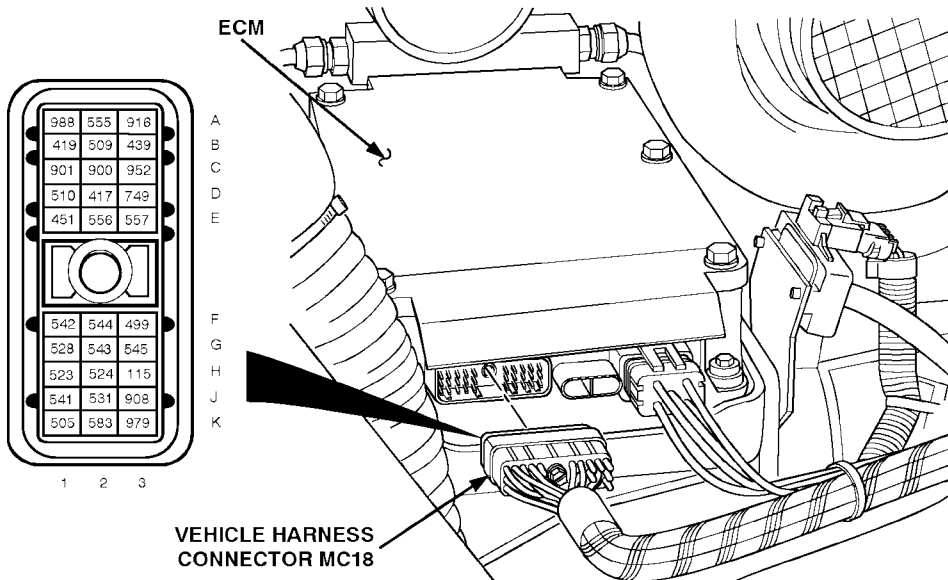
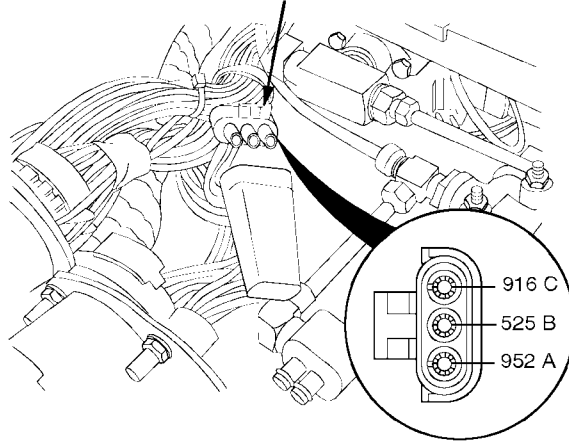

Section 4 TROUBLESHOOTING CHARTS

E. FLASH CODE: 12
J1587 CODE: P187 3 - POWER TAKE OFF (PTO) INPUT FAILED HIGH (HIGH VOLTAGE)
(ALSO CALLED VARIABLE SPEED GOVERNOR - VSG)

STEP/SEQUENCE	RESULT	WHAT TO DO NEXT
<p>12-5 Check for Short to +5 Volt Line</p> <ul style="list-style-type: none"> • Connect all connectors to ECM. Turn ignition on. • Read voltage on vernier control harness connector pin B (525) to pin A (952). 	<p>Greater than 1.0 volts. →</p> <p>Less than or equal to 1.0 volts. →</p>	<p>Signal line (ckt #510 or #525) is shorted to the vehicle +5 volt line (ckt #916) or another voltage source. Repair short. Then go to 12-30.</p> <p>Go to 12-7.</p>
<p>12-6 (Deleted)</p>		
<p>12-7 Check ECM Connectors</p> <ul style="list-style-type: none"> • Disconnect the vehicle harness connector. • Check terminals at the vehicle harness connector (both ECM and harness side) for damage; bent, corroded, and unseated pins or sockets. 	<p>Terminals and connectors are okay. →</p> <p>Problem found. →</p>	<p>Replace ECM (para 7-29.1). Then go to 12-30.</p> <p>Repair terminals/connectors (para 7-77). Then go to 12-30.</p>

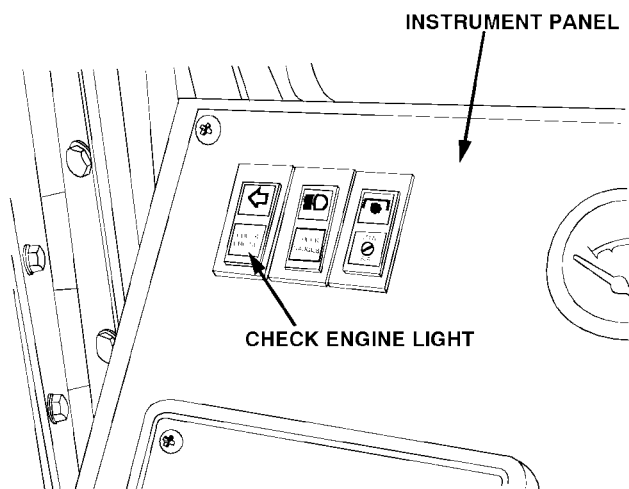

Section 4 TROUBLESHOOTING CHARTS

E. FLASH CODE: 12
J1587 CODE: P187 3 - POWER TAKE OFF (PTO) INPUT FAILED HIGH (HIGH VOLTAGE)
(ALSO CALLED VARIABLE SPEED GOVERNOR - VSG)

STEP/SEQUENCE	RESULT	WHAT TO DO NEXT
<p>12-30 Verify Repairs</p> <ul style="list-style-type: none"> • Turn ignition off. • Reconnect all connectors. • Turn ignition on. • Clear codes. • Note status of "Check Engine" light. • If "Check Engine" light does not stay on, start engine and run (TM 9-2350-360-10) until "Check Engine" light comes on or 1 minute. Stop engine. • Read inactive codes. 	<p>No codes. →</p> <p>Code 187/3 (and any other codes). →</p> <p>Any other codes except Code 187/3. →</p>	<p>Repairs are complete.</p> <p>All system diagnostics are complete. Please review this section from the first step to find the error.</p> <p>Go to START-1, pg H-25, to service other codes.</p>

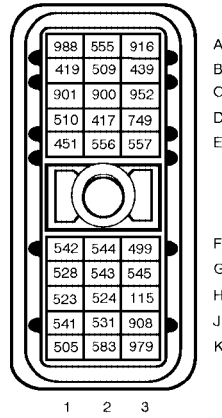
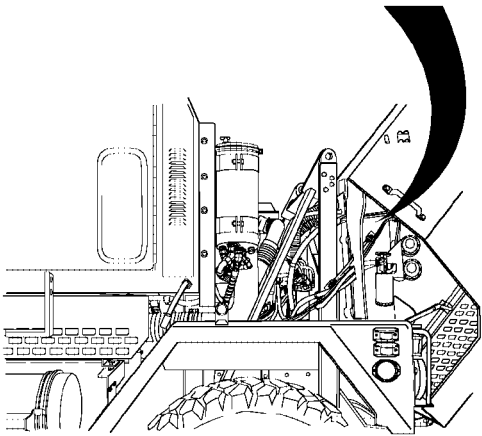
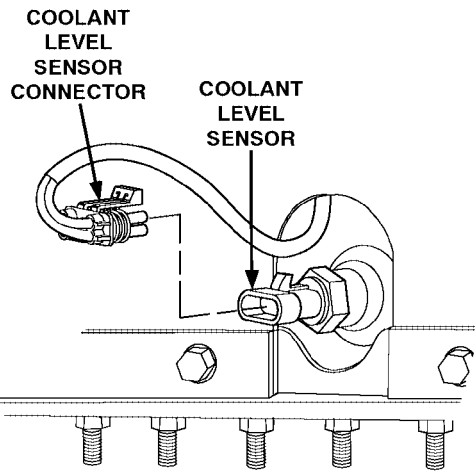

A
B
C
D
E
F
G
H
J
K

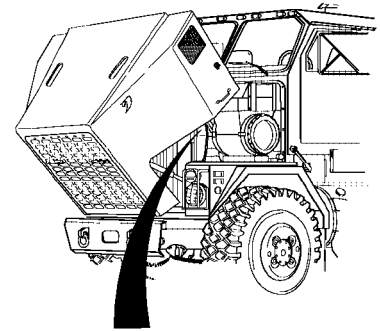

ECM

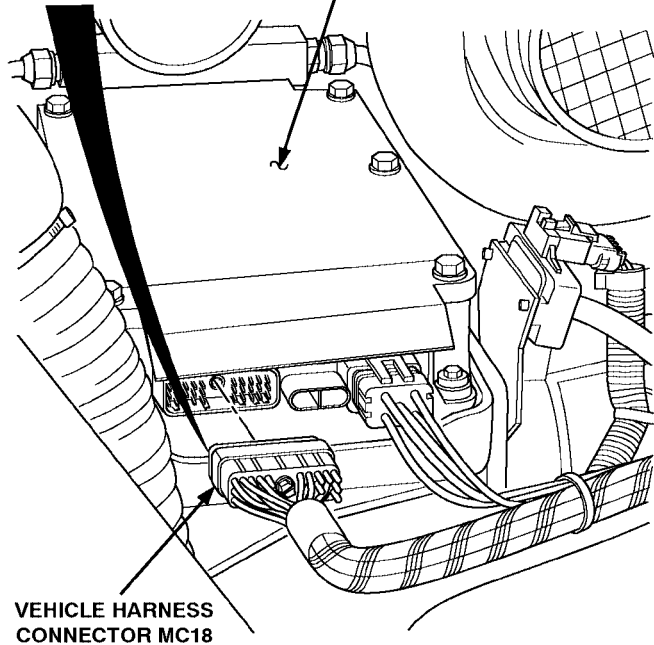

Section 4 TROUBLESHOOTING CHARTS

E. FLASH CODE: 13
J1587 CODE: P111 4 - COOLANT LEVEL CIRCUIT FAILED LOW (LOW VOLTAGE)

NOTE - This chart is only to be used if:

- 1) All basic mechanical checks and physical inspections have been performed with no problem found, and
- 2) Diagnosis of DDEC-III/IV was started at step START-1, pg H-25 and you have now been referred here.

STEP/SEQUENCE	RESULT	WHAT TO DO NEXT
<p>13-1 Sensor Check</p> <ul style="list-style-type: none"> • Turn ignition off. • Disconnect CLS connector. • Turn ignition on. • Start engine. • Read active codes. • Stop engine. 	<p>Code P111/3 (and any other codes). →</p> <p>Code P111/4 (and any other codes). →</p>	<p>Go to 16-1.</p> <p>Go to 13-3.</p>
<p>13-2 Check CLS Connectors</p> <ul style="list-style-type: none"> • Inspect terminals at the CLS connector for damage; bent, corroded, and unseated pins or sockets. Also ensure wires are not reversed at the CLS. 	<p>Terminals and connectors are okay. →</p> <p>Problem found. →</p>	<p>Replace CLS (para 7-10). Then go to 13-30.</p> <p>Repair terminals/connectors (para 7-77). Then go to 13-30.</p>
<p>13-3 Check for Short to Ground</p> <ul style="list-style-type: none"> • Turn ignition off. • Disconnect the vehicle harness connector at the ECM. • Read resistance between sockets A & B of the CLS connector. 	<p>Less than or equal to 10,000 ohms. →</p> <p>Greater than 10,000 ohms or open. →</p>	<p>Signal line (ckt #115) is shorted to ground (ckt #953). Repair short. Then go to 13-30.</p> <p>Go to 13-2.</p>

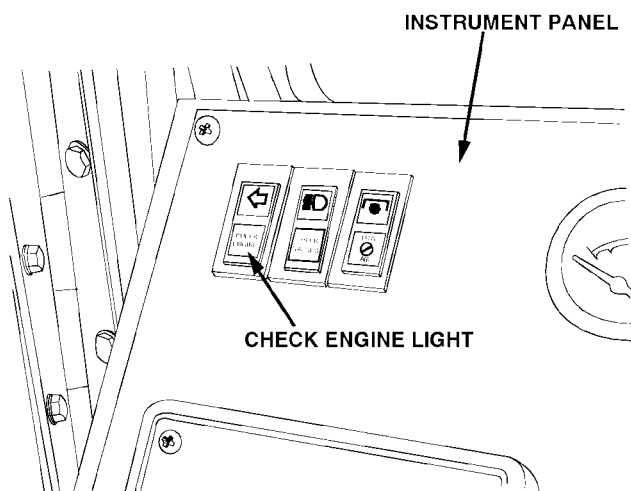

Section 4 TROUBLESHOOTING CHARTS

E. FLASH CODE: 13
 J1587 CODE: P111 4 - COOLANT LEVEL CIRCUIT FAILED LOW (LOW VOLTAGE)

STEP/SEQUENCE	RESULT	WHAT TO DO NEXT
<p>13-30 Verify Repairs</p> <ul style="list-style-type: none"> • Turn ignition off. • Reconnect all connectors. • Turn ignition on. • Clear codes. • Note status of "Check Engine" light. • If "Check Engine" light does not stay on, start engine and run (TM 9-2320-360-10) until "Check Engine" light comes on or 1 minute. Stop engine. • Read inactive codes. 	<p>No codes. →</p> <p>Code 111/4 (and any other codes). →</p> <p>Any other codes except Code 111/4. →</p>	<p>Repairs are complete.</p> <p>All system diagnostics are complete. Please review this section from the first step to find the error.</p> <p>Go to START-1, pg H-25, to service other codes.</p>

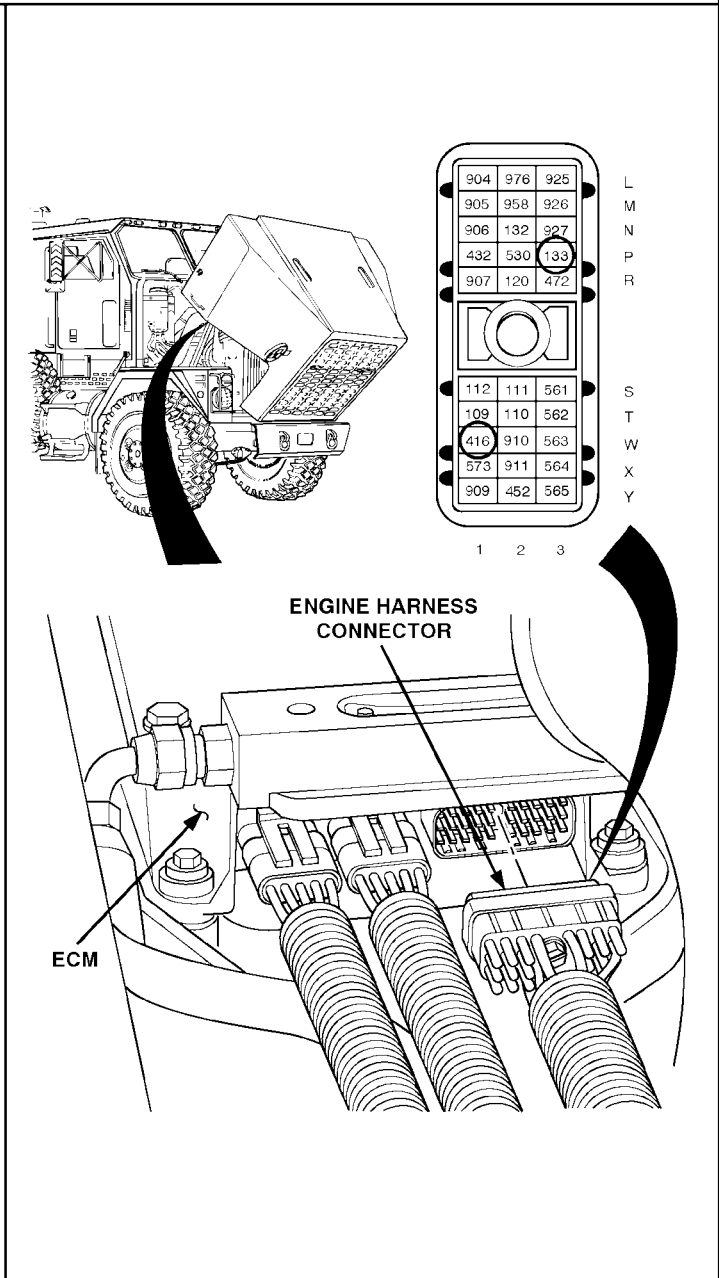
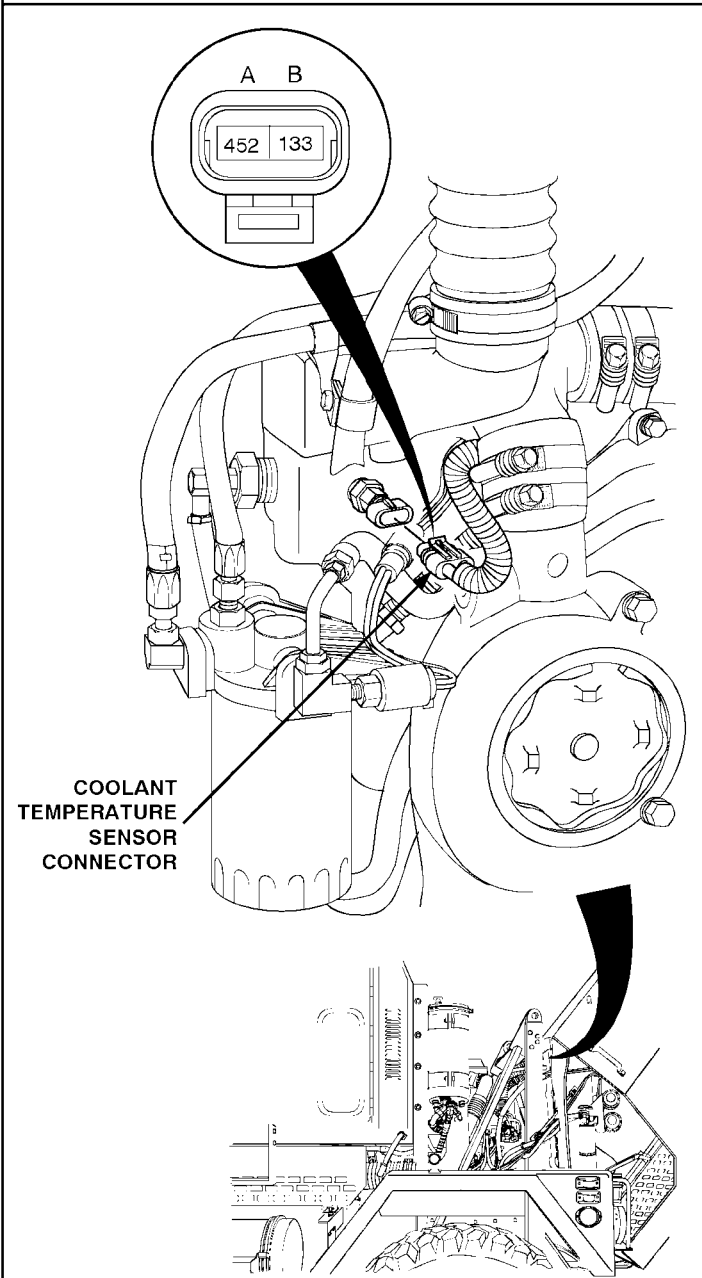
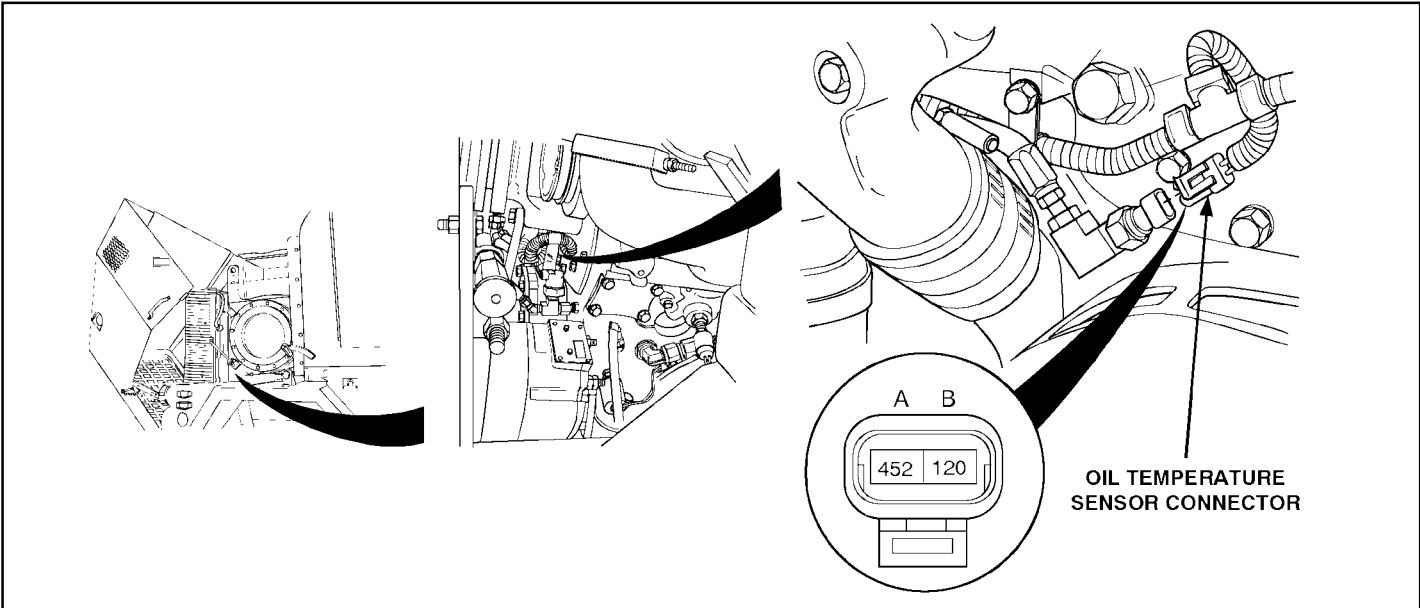

Section 4 TROUBLESHOOTING CHARTS

E. FLASH CODE: 14
J1587 CODE: P110 3 - COOLANT TEMPERATURE CIRCUIT FAILED HIGH (VOLTAGE HIGH) (BELOW)
OR: P175 3 - OIL TEMPERATURE CIRCUIT FAILED HIGH (VOLTAGE HIGH) (BELOW)

NOTE - This chart is only to be used if:

- 1) All basic mechanical checks and physical inspections have been performed with no problem found, and
- 2) Diagnosis of DDEC-III/IV was started at step START-1, pg H-25 and you have now been referred here.

STEP/SEQUENCE	RESULT	WHAT TO DO NEXT
<p>14-1 Code Check</p> <ul style="list-style-type: none"> • Turn ignition on. • Plug in DDR and determine which code is present. 	<p>PID 110 - FMI 3 →</p> <p>PID 175 - FMI 3 →</p>	<p>Go to 14-2.</p> <p>Go to 14-3.</p>
<p>14-2 Coolant Temp Sensor Check</p> <ul style="list-style-type: none"> • Turn ignition off. • Disconnect CTS and install a jumper between the CTS connector sockets A and B. • Turn ignition on. • Read active codes. 	<p>Code 110/4 (or any codes except Code 110/3) →</p> <p>Anything except Code 110/4. →</p>	<p>Go to 14-4.</p> <p>Go to 14-8.</p>
<p>14-3 Oil Temp Sensor Check</p> <ul style="list-style-type: none"> • Turn ignition off. • Disconnect OTS and install jumper between OTS connector sockets A and B. • Turn ignition on. • Read active codes. 	<p>Code 175/4 (or any codes except Code 175/4) →</p> <p>Anything except Code 175/4. →</p>	<p>Go to 14-5.</p> <p>Go to 14-9.</p>
<p>14-4 Check for Short to +5 Volt Line</p> <ul style="list-style-type: none"> • Turn ignition off. • Remove jumper wire. • Disconnect the engine harness connector at the ECM. • Read resistance between sockets P3 (ckt #133) and W1 (ckt #416) on the engine harness connector. 	<p>Less than or equal to 10,000 ohms. →</p> <p>Greater than 10,000 ohms or open. →</p>	<p>Signal line (ckt #133) is shorted to the engine +5 volt line (ckt #416), and/or (ckt #133) signal line is shorted to ground and/or sensor return (ckt #452). Repair short. Then go to 14-30.</p> <p>Go to 14-6.</p>

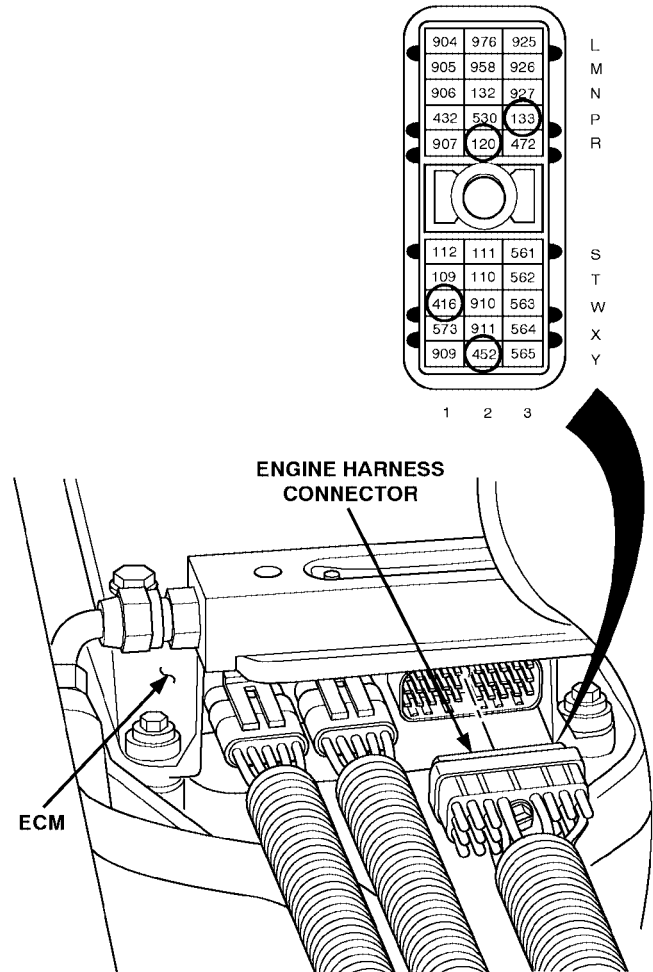
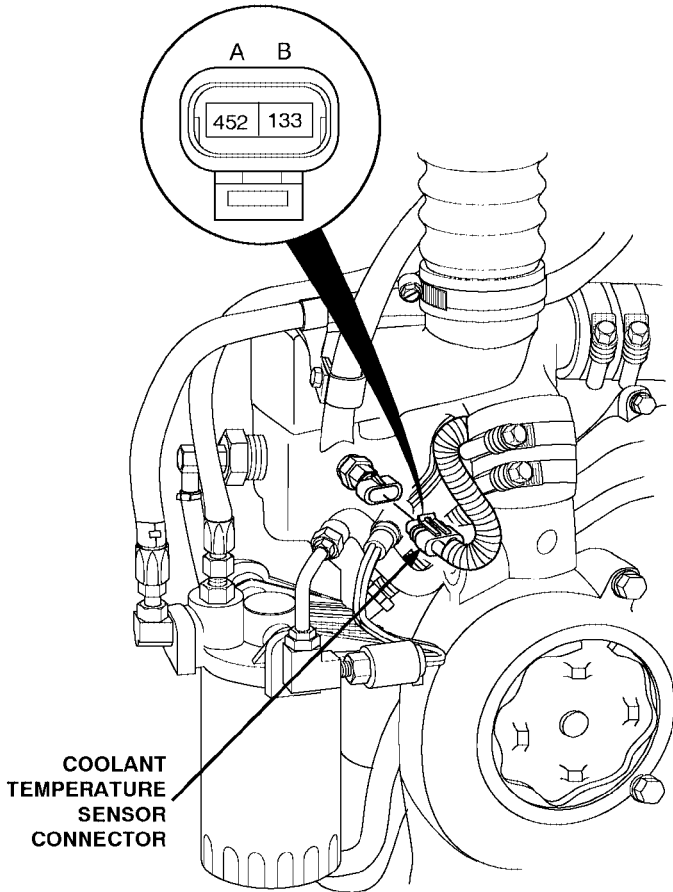
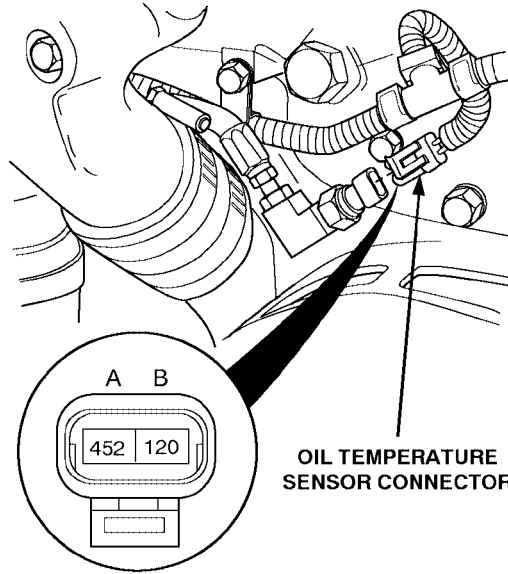

Section 4 TROUBLESHOOTING CHARTS

E. FLASH CODE: 14
J1587 CODE: P110 3 - COOLANT TEMPERATURE CIRCUIT FAILED HIGH (VOLTAGE HIGH)
OR: P175 3 - OIL TEMPERATURE CIRCUIT FAILED HIGH (VOLTAGE HIGH)

STEP/SEQUENCE	RESULT	WHAT TO DO NEXT
<p>14-5 Check for Short to +5 Volt Line</p> <ul style="list-style-type: none"> • Turn ignition off. • Remove jumper wire. • Disconnect the engine harness connector at the ECM. • Read resistance between sockets R2 (ckt #120) and W1 (ckt #416) on the engine harness connector. 	<p>Less than or equal to 10,000 ohms. →</p> <p>Greater than 10,000 ohms or open. →</p>	<p>Signal line (ckt #120) is shorted to the engine +5 volt line (ckt #416), and/or (ckt #120) signal line is shorted to ground and/or sensor return (ckt #452). Repair short. Then go to 14-30.</p> <p>Go to 14-7.</p>
<p>14-6 Check CTS Connectors</p> <ul style="list-style-type: none"> • Inspect terminals at the CTS connector (both the sensor and harness side) for damage; bent, corroded, and unseated pins or sockets. 	<p>Terminals and connectors are okay. →</p> <p>Problem found. →</p>	<p>Replace CTS (para 7-36.1). Then go to 14-30.</p> <p>Repair terminals/connectors (para 7-77). Then go to 14-30.</p>
<p>14-7 Check OTS Connectors</p> <ul style="list-style-type: none"> • Inspect terminals at the OTS connector (both the sensor and harness side) for damage; bent, corroded, and unseated pins or sockets. 	<p>Terminals and connectors are okay. →</p> <p>Problem found. →</p>	<p>Replace OTS (para 7-34). Then go to 14-30.</p> <p>Repair terminals/connectors (para 7-77). Then go to 14-30.</p>
<p>14-8 Open line Check</p> <ul style="list-style-type: none"> • Turn ignition off. • Disconnect the engine harness connector at the ECM. • Read resistance between sockets P3 (ckt #133) and Y2 (ckt #452) on the engine harness connector. 	<p>Less than or equal to 5 ohms. →</p> <p>Greater than 5 ohms or open. →</p>	<p>Go to 14-10.</p> <p>Signal line (ckt #133) or return line (ckt #452) is open. Repair open. Then go to 14-30.</p>

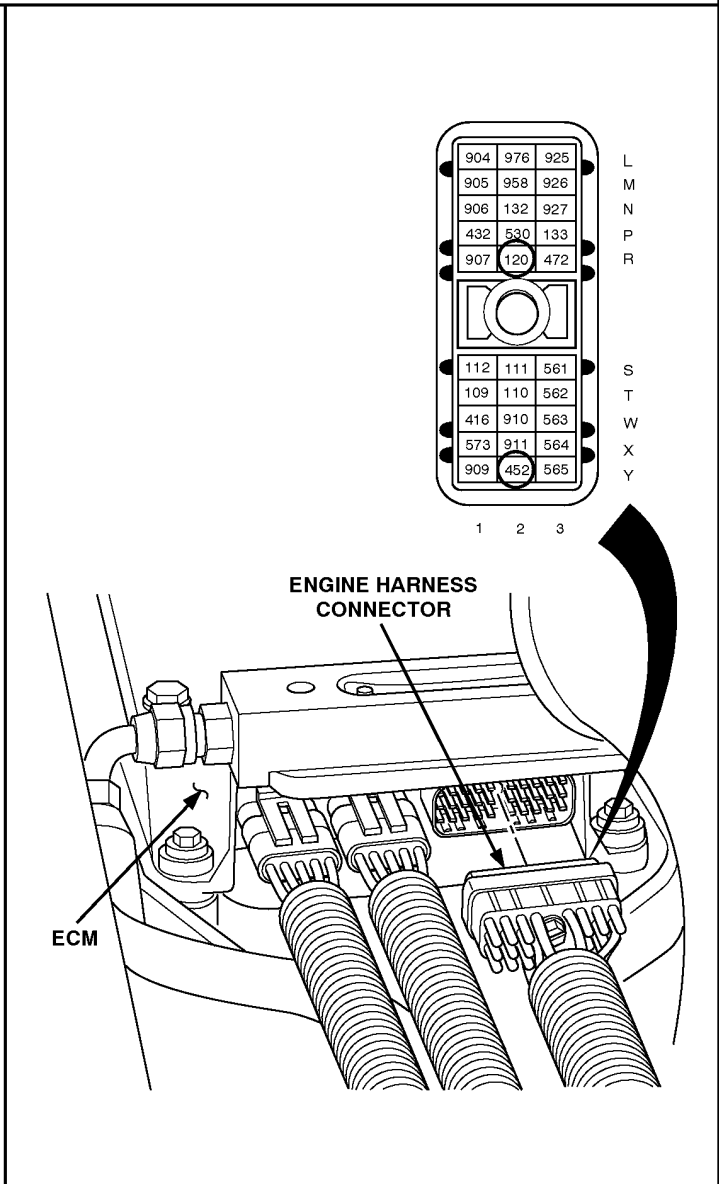
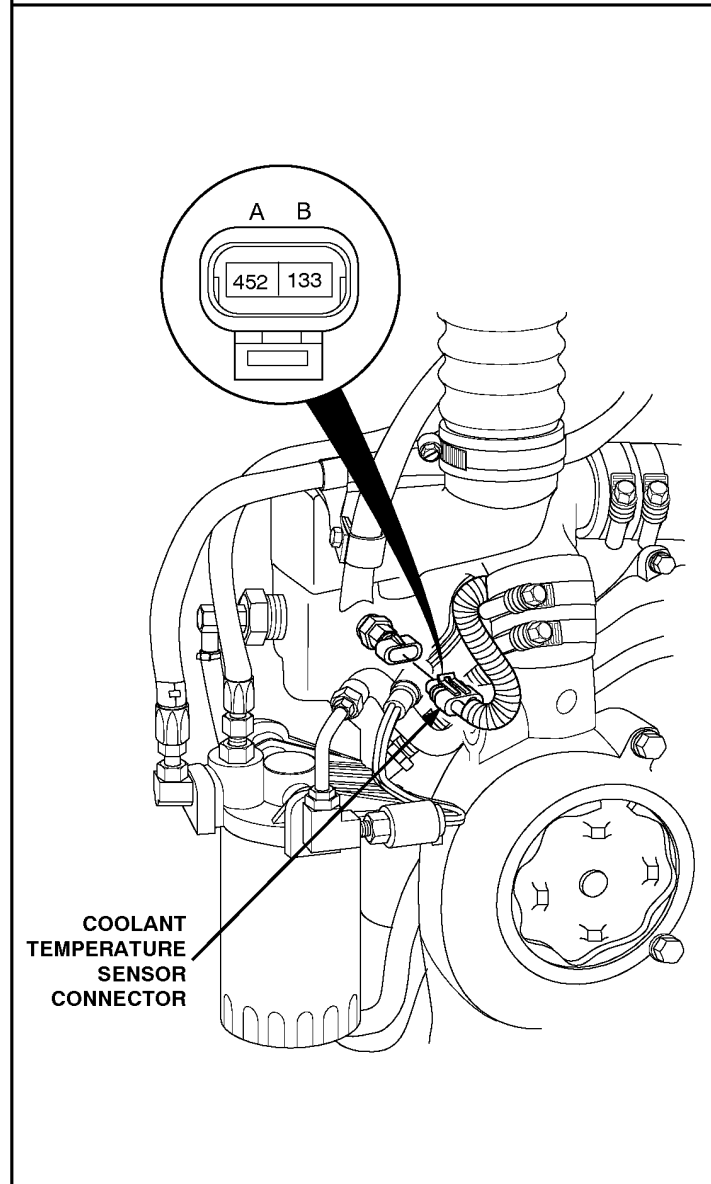
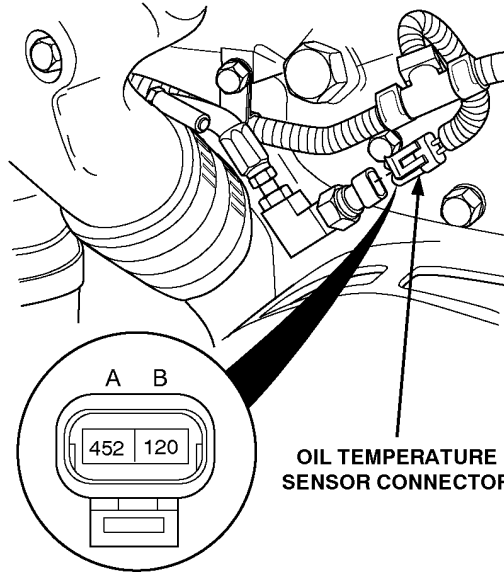

Section 4 TROUBLESHOOTING CHARTS

E. FLASH CODE: 14
J1587 CODE: P110 3 - COOLANT TEMPERATURE CIRCUIT FAILED HIGH (VOLTAGE HIGH)
OR: P175 3 - OIL TEMPERATURE CIRCUIT FAILED HIGH (VOLTAGE HIGH)

STEP/SEQUENCE	RESULT	WHAT TO DO NEXT
<p>14-9 Open line Check</p> <ul style="list-style-type: none"> • Turn ignition off. • Disconnect the engine harness connector at the ECM. • Read resistance between sockets R2 (ckt #120) and Y2 (ckt #452) on the engine harness connector. 	<p>Less than or equal to 5 ohms. →</p> <p>Greater than 5 ohms or open. →</p>	<p>Go to 14-11.</p> <p>Signal line (ckt #120) or return line (ckt #452) is open. Repair open. Then go to 14-30.</p>
<p>14-10 Check ECM Connectors</p> <ul style="list-style-type: none"> • Check terminals at the ECM engine harness connector (both the ECM and harness side) for damage; bent, corroded, and unseated pins or sockets. 	<p>Terminals and connectors are okay. →</p> <p>Problem found. →</p>	<p>Replace ECM (para 7-29.1). Then go to 14-30.</p> <p>Repair terminals/connectors (para 7-77). Then go to 14-30.</p>
<p>14-11 Check ECM Connectors</p> <ul style="list-style-type: none"> • Check terminals at the engine harness connector (both the ECM and harness side) for damage; bent, corroded, and unseated pins or sockets. 	<p>Terminals and connectors are okay. →</p> <p>Problem found. →</p>	<p>Replace ECM (para 7-29.1). Then go to 14-30.</p> <p>Repair terminals/connectors (para 7-77). Then go to 14-30.</p>
<p>14-30 Verify Repairs</p> <ul style="list-style-type: none"> • Turn ignition off. • Reconnect all connectors. • Turn ignition on. • Clear codes. • Note status of "Check Engine" light. • If "Check Engine" light does not stay on, start engine and run (TM 9-2320-360-10) until "Check Engine" light comes on or after 8 minutes. Stop engine. • Read inactive codes. 	<p>No codes. →</p> <p>Code 110/3 or 175/3 (any other codes.) →</p> <p>Any other codes except Codes 110/3 or 175/3. →</p>	<p>Repairs are complete.</p> <p>All system diagnostics are complete. Please review this section from the start to find the error.</p> <p>Go to START-1, pg H-25, to service other codes.</p>

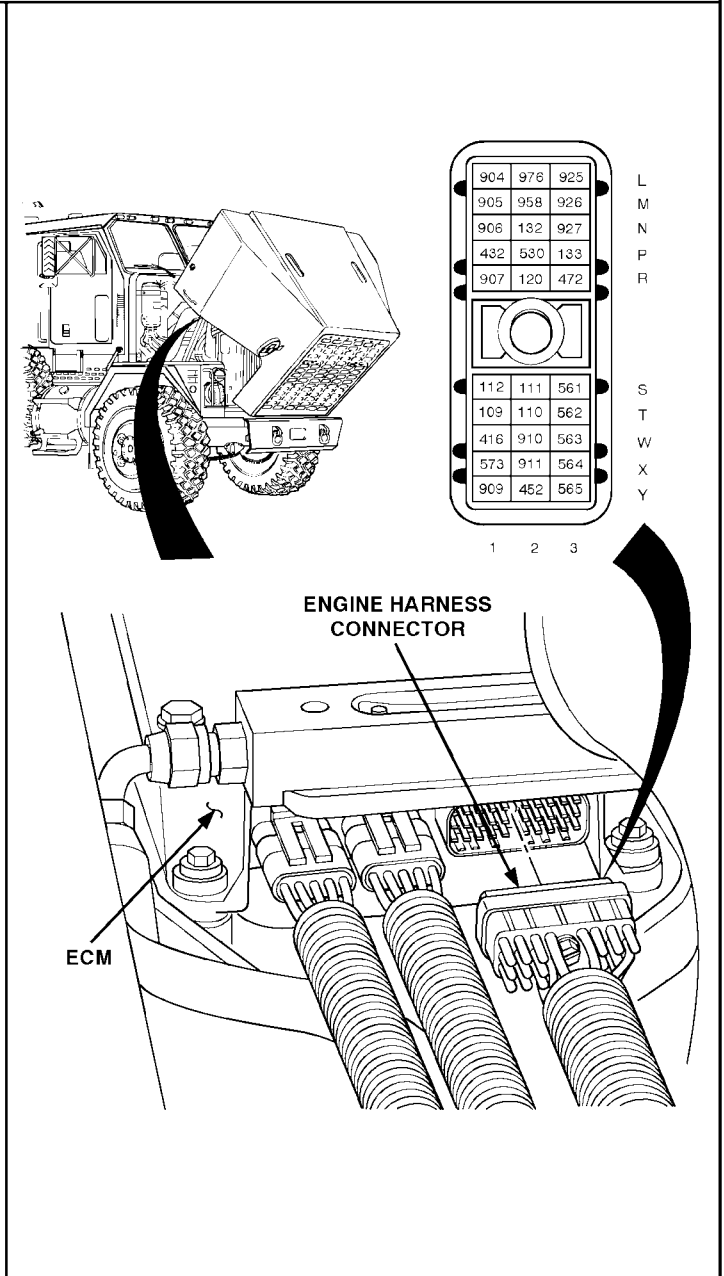
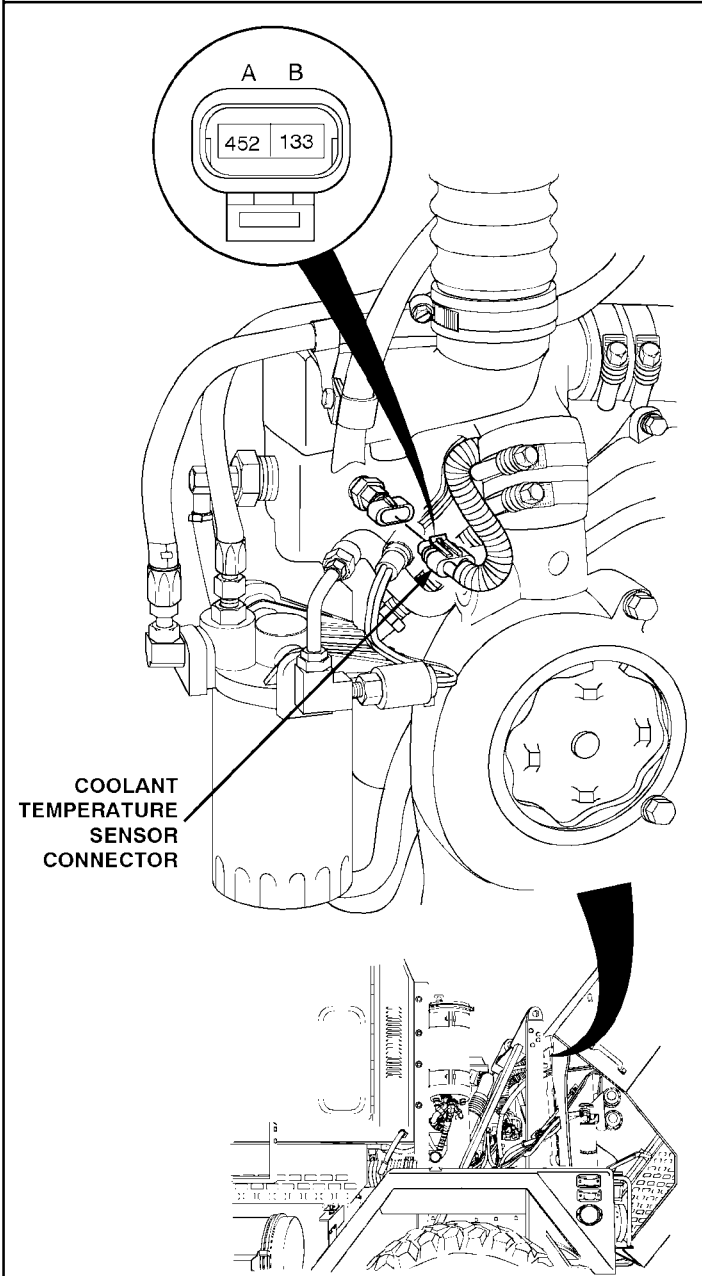
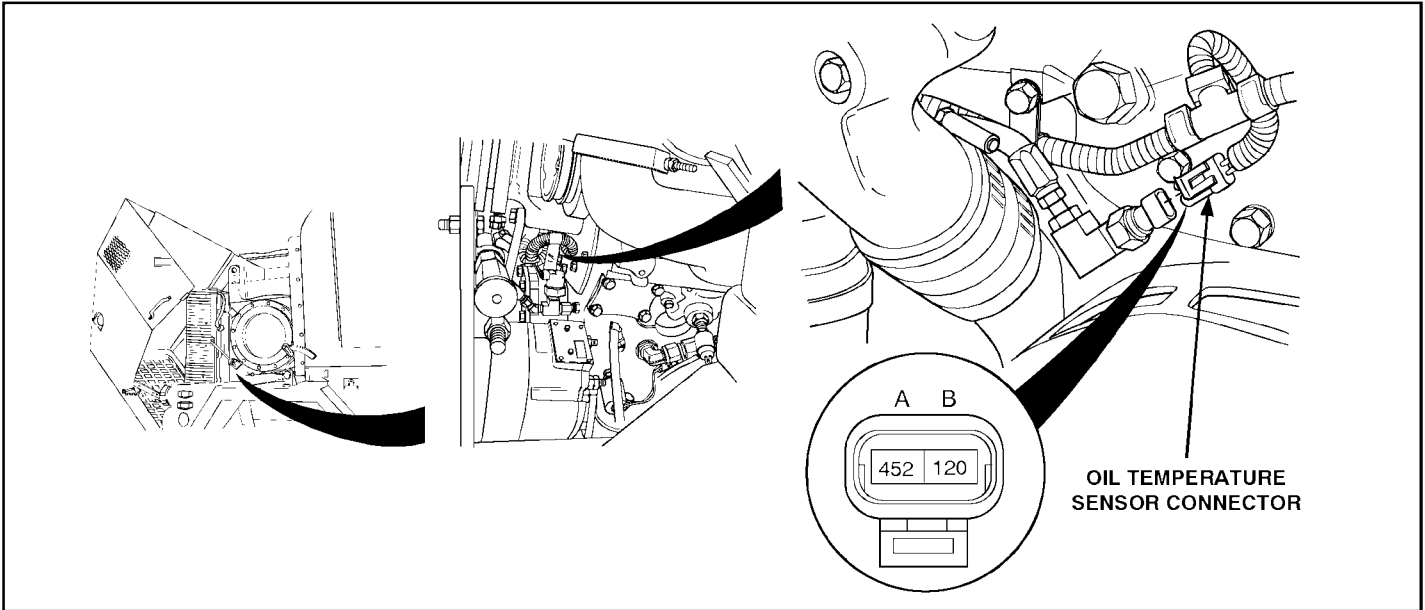

Section 4 TROUBLESHOOTING CHARTS

E. FLASH CODE: 15
J1587 CODE: P110 4 - COOLANT TEMPERATURE CIRCUIT FAILED LOW (LOW VOLTAGE)
OR: P175 4 - OIL TEMPERATURE CIRCUIT FAILED LOW (LOW VOLTAGE)

NOTE - This chart is only to be used if:

- 1) All basic mechanical checks and physical inspections have been performed with no problem found, and
- 2) Diagnosis of DDEC-III/IV was started at step START-1, pg H-25 and you have now been referred here.

STEP/SEQUENCE	RESULT	WHAT TO DO NEXT
<p>15-1 Code Check</p> <ul style="list-style-type: none"> • Turn ignition on. • Plug in DDR and determine which code is present. 	<p>PID 110 - FMI 4 →</p> <p>PID 175 - FMI 4 →</p>	<p>Go to 15-2.</p> <p>Go to 15-3.</p>
<p>NOTE: If any of the following SAE J1587 Codes are also present go to ENG5V-2 (page H-241): 110/3, 174/3, 174/4, 187/4, 91/4, 100/4, 102/4, and 102/3</p>		
<p>15-2 Coolant Temp Sensor Check</p> <ul style="list-style-type: none"> • Turn ignition off. • Disconnect CTS connector. • Start engine and run until "Check Engine" light comes on or after 8 minutes. • Read active codes with engine still running. 	<p>Any codes except Code 110/4. →</p> <p>Code 110/4 (and any other codes). →</p>	<p>Go to 15-4.</p> <p>Go to 15-6.</p>
<p>15-3 Oil Temp Sensor Check</p> <ul style="list-style-type: none"> • Turn ignition off. • Disconnect OTS connector. • Start engine and run (TM 9-2320-360-10) until "Check Engine" light comes on or after 8 minutes. • Read active codes with engine still running. 	<p>Any codes except Code 175/4. →</p> <p>Code 175/4 (and any other codes). →</p>	<p>Go to 15-5.</p> <p>Go to 15-7.</p>
<p>15-4 Check CTS Connectors</p> <ul style="list-style-type: none"> • Inspect terminals at the CTS connector (both the sensor and harness side) for damage; bent, corroded, and unseated pins or sockets. 	<p>Terminals and connectors are okay. →</p> <p>Problem found. →</p>	<p>Replace CTS (para 7-36.1). Then go to 15-30.</p> <p>Repair terminals/connectors (para 7-77). Then go to 15-30.</p>

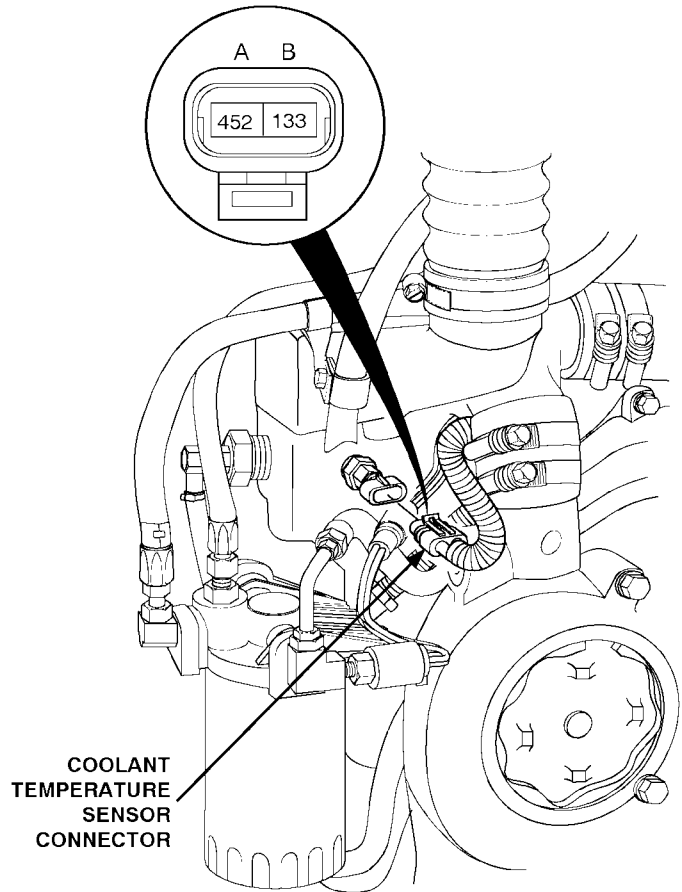
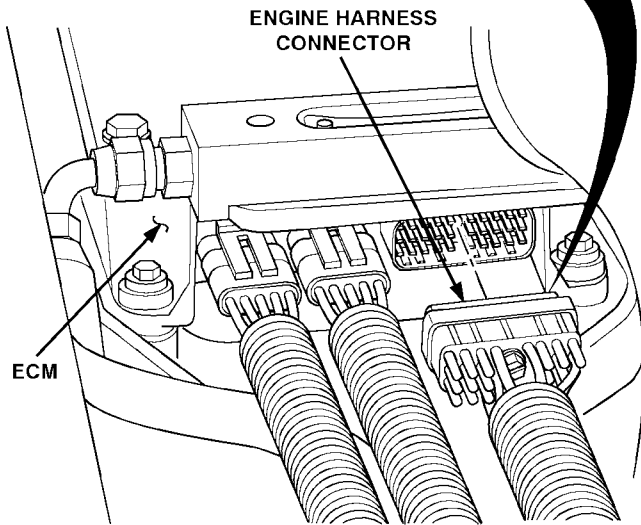
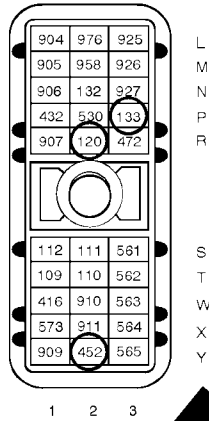
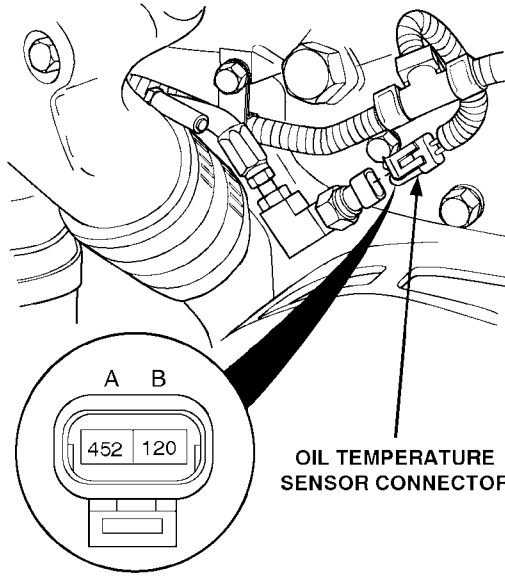

Section 4 TROUBLESHOOTING CHARTS

E. FLASH CODE: 15
 J1587 CODE: P110 4 - COOLANT TEMPERATURE CIRCUIT FAILED LOW (LOW VOLTAGE)
 OR: P175 4 - OIL TEMPERATURE CIRCUIT FAILED LOW (LOW VOLTAGE)

STEP/SEQUENCE	RESULT	WHAT TO DO NEXT
<p>15-5 Check OTS Connectors</p> <ul style="list-style-type: none"> • Inspect terminals at the OTS connector (both the sensor and harness side) for damage; bent, corroded, and unseated pins or sockets. 	<p>Terminals and connectors are okay. →</p> <p>Problem found. →</p>	<p>Replace OTS (para 7-34). Then go to 15-30.</p> <p>Repair terminals/connectors (para 7-77). Then go to 15-30.</p>
<p>15-6 Check for Short</p> <ul style="list-style-type: none"> • Turn ignition off. • Disconnect engine harness connector at the ECM. • Read resistance between sockets P3 (ckt #133) and Y2 (ckt #452) on the engine harness connector. • Also read resistance between socket B of CTS connector and a good ground. 	<p>Less than or equal to 10,000 ohms on either reading. →</p> <p>Greater than 10,000 ohms or open on both readings. →</p>	<p>Signal line (ckt #133) is shorted to the return line (ckt #452) or battery ground. Repair short. Then go to 15-30.</p> <p>Go to 15-8.</p>
<p>15-7 Check for Short</p> <ul style="list-style-type: none"> • Turn ignition off. • Disconnect engine harness connector at the ECM. • Read resistance between sockets R2 (ckt #120) and Y2 (ckt #452) on the engine harness connector. • Also read resistance between socket B of OTS connector and a good ground. 	<p>Less than or equal to 10,000 ohms on either reading. →</p> <p>Greater than 10,000 ohms or open on both readings. →</p>	<p>Signal line (ckt #120) is shorted to the return line (ckt #452) or battery ground. Repair short. Then go to 15-30.</p> <p>Go to 15-9.</p>

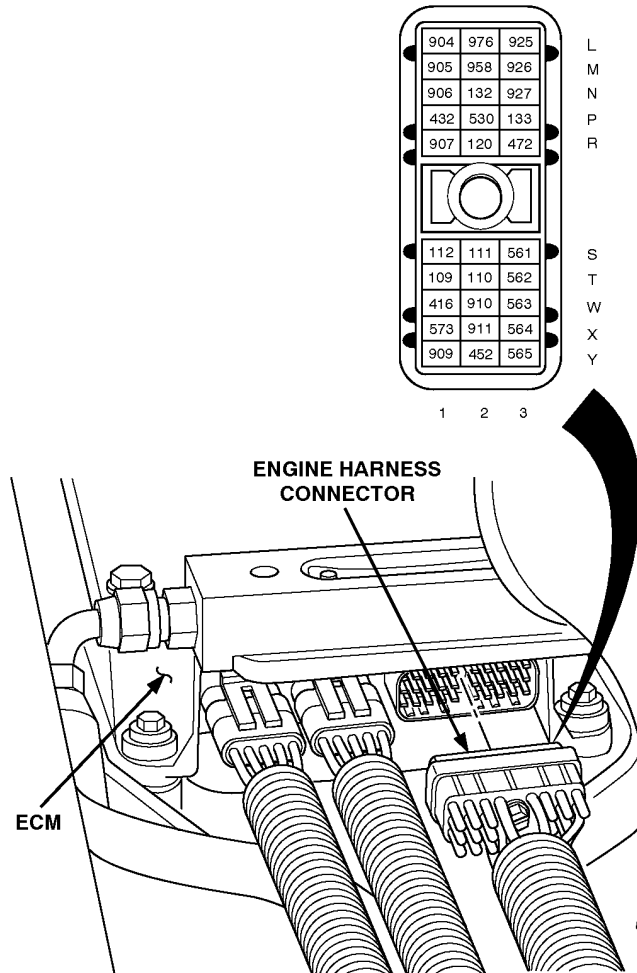
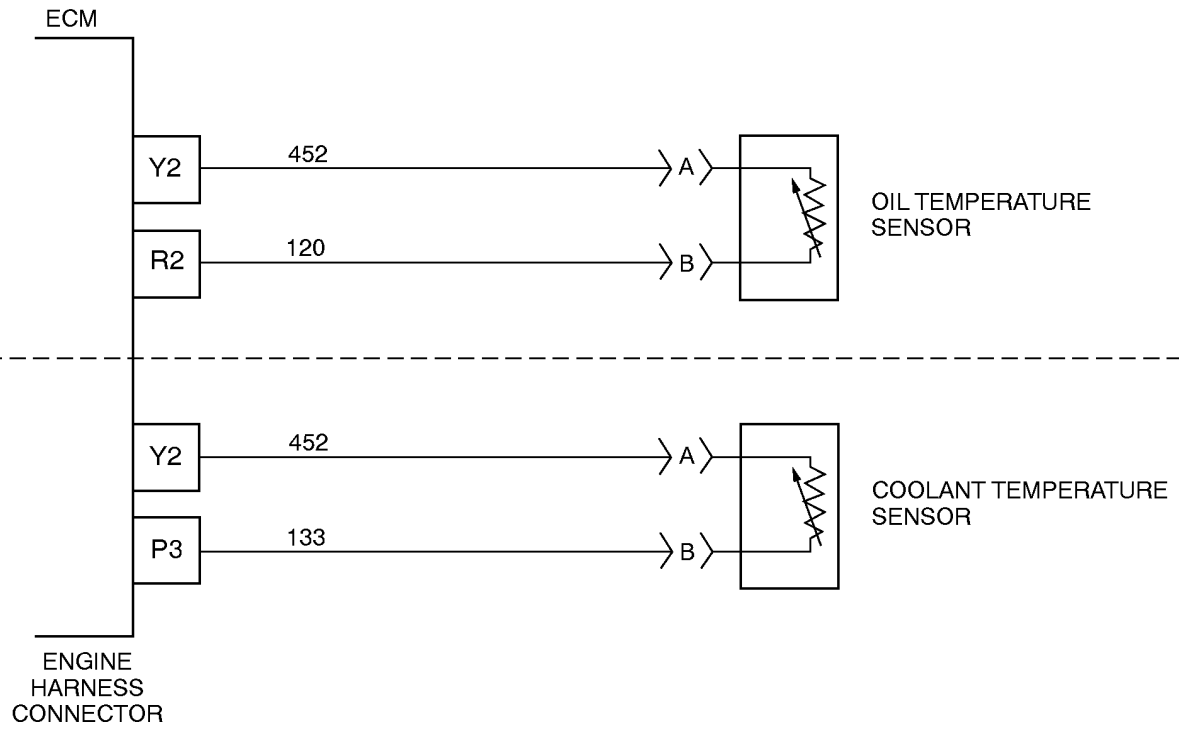

Section 4 TROUBLESHOOTING CHARTS

E. FLASH CODE: 15
J1587 CODE: P110 4 - COOLANT TEMPERATURE CIRCUIT FAILED LOW (LOW VOLTAGE)
OR: P175 4 - OIL TEMPERATURE CIRCUIT FAILED LOW (LOW VOLTAGE)

STEP/SEQUENCE	RESULT	WHAT TO DO NEXT
<p>15-8 Check ECM Connectors</p> <ul style="list-style-type: none"> • Check terminals at the engine harness connector (both the ECM and harness side) for damage; bent, corroded, and unseated pins or sockets. Especially terminals P3 and Y2 of the engine harness connector. 	<p>Terminals and connectors are okay. →</p> <p>Problem found. →</p>	<p>Replace ECM (para 7-29.1). Then go to 15-30.</p> <p>Repair terminals/connectors (para 7-77). Then go to 15-30.</p>
<p>15-9 Check ECM Connectors</p> <ul style="list-style-type: none"> • Check terminals at the engine harness connector (both the ECM and harness side) for damage; bent, corroded, and unseated pins or sockets. Especially terminals R2 and Y2 of the engine harness connector. 	<p>Terminals and connectors are okay. →</p> <p>Problem found. →</p>	<p>Replace ECM (para 7-29.1). Then go to 15-30.</p> <p>Repair terminals/connectors (para 7-77).</p>
<p>15-30 Verify Repairs</p> <ul style="list-style-type: none"> • Turn ignition off. • Reconnect all connectors. • Turn ignition on. • Clear codes. • Note status of "Check Engine" light. • If "Check Engine" light does not stay on, start engine and run (TM 9-2320-360-10) until "Check Engine" light comes on or for 1 minute. Stop engine. • Read inactive codes. 	<p>No codes. →</p> <p>Code 110 or 175/4 (and any other codes). →</p> <p>Any other codes except Code 110 or 175/4. →</p>	<p>Repairs are complete.</p> <p>All system diagnostics are complete. Please review this section from the start to find the error.</p> <p>Go to START-1, pg H-25, to service other codes.</p>

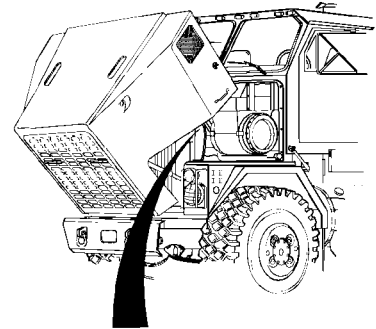
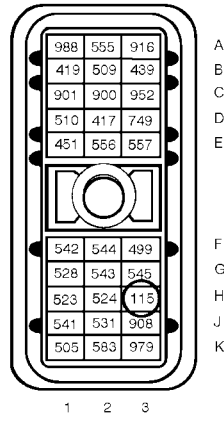
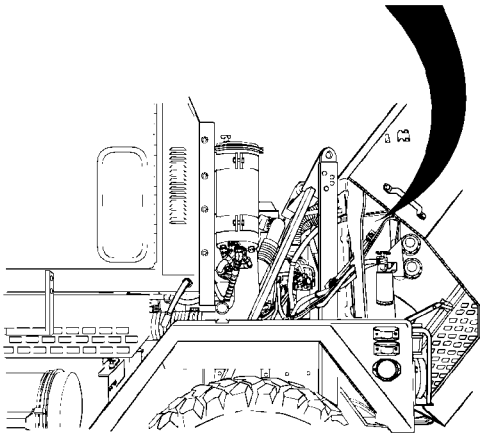
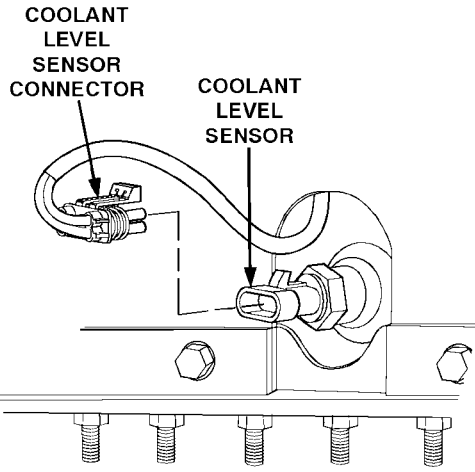

ECM

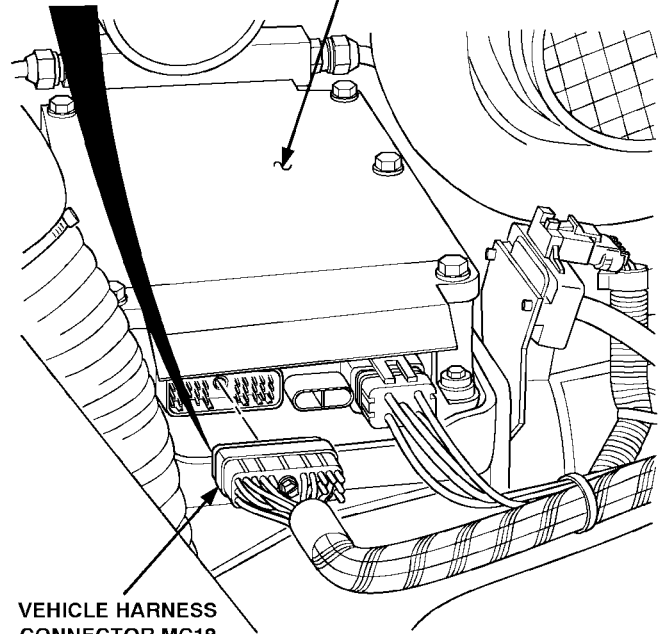

DDEC IGNITION CIRCUIT BREAKER

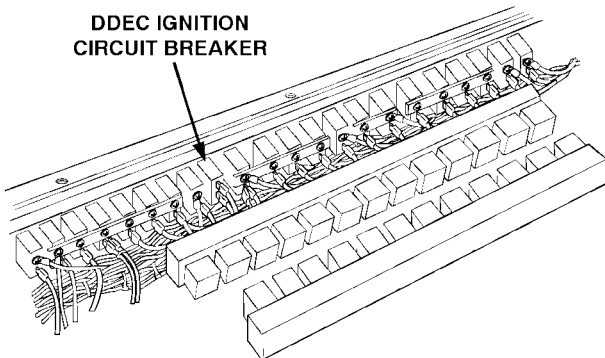

Section 4 TROUBLESHOOTING CHARTS

E. FLASH CODE: 16
J1587 CODE: P111 3 - COOLANT LEVEL CIRCUIT FAILED HIGH (VOLTAGE HIGH)

NOTE - This chart is only to be used if:

- 1) All basic mechanical checks and physical inspections have been performed with no problem found, and
- 2) Diagnosis of DDEC-III/IV was started at step START-1, pg H-25 and you have now been referred here.

STEP/SEQUENCE	RESULT	WHAT TO DO NEXT
<p>16-1 Sensor Check</p> <ul style="list-style-type: none"> • Turn ignition off. • Disconnect CLS connector and install a jumper between sockets A and B of the CLS connector. • Attempt to start and run engine at idle (TM 9-2320-360-10). • Read active codes. • Stop engine. 	<p>Engine will not start. → Go to 16-3.</p> <p>Code 111/3 (and any other codes except Code 111/4). → Go to 16-2.</p> <p>Code 111/4 (and any other codes). → Go to 16-5.</p>	
<p>16-2 Signal and Ground Circuit Check</p> <ul style="list-style-type: none"> • Turn ignition off. • Disconnect the vehicle harness connector. • Read resistance between socket H3 (ckt #115) on the vehicle harness connector and a good ground. 	<p>Less than or equal to 5 ohms. → Go to 16-6.</p> <p>Greater than 5 ohms or open. → Either the CLS signal line (ckt #115) or the battery ground line is open. Repair open. Then go to 16-30.</p>	
<p>16-3 Check if Ignition Circuit Breaker is Open</p> <ul style="list-style-type: none"> • Check if the DDEC ignition circuit breaker (CB11) is tripped. 	<p>Open circuit breaker. → Reset circuit breaker. Then go to 16-4.</p> <p>Circuit breaker is okay. → Go to 16-4.</p>	

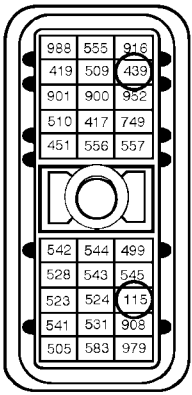

A
B
C
D
E

F
G
H
J
K

1 2 3

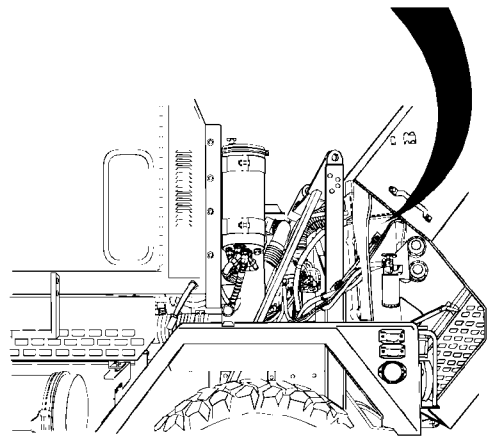
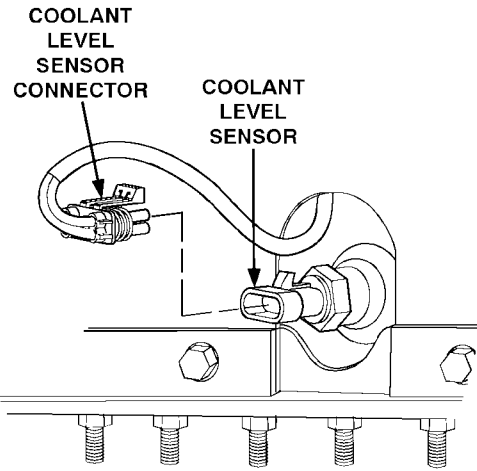
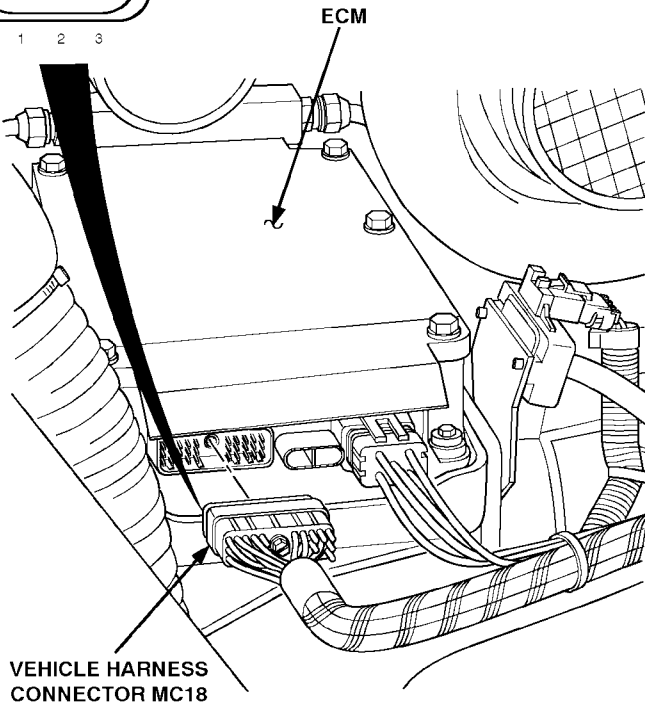

Section 4 TROUBLESHOOTING CHARTS

E. FLASH CODE: 16
J1587 CODE: P111 3 - COOLANT LEVEL CIRCUIT FAILED HIGH (VOLTAGE HIGH)

STEP/SEQUENCE	RESULT	WHAT TO DO NEXT
<p>16-4 Check for Signal Short to Ignition</p> <ul style="list-style-type: none"> • Disconnect the vehicle harness connector at the ECM. • Remove jumper wire at the CLS connector. • Read resistance between sockets H3 (ckt #115) and B3 (ckt #439) of vehicle harness connector. 	<p>Less than 10,000 ohms. →</p> <p>Greater than or equal to 10,000 ohms or open. →</p>	<p>The CLS signal line (ckt #115) is shorted to the ignition line (ckt #439). Repair short. Then go to 16-30.</p> <p>Go to 16-5.</p>
<p>16-5 Check ECM Connectors</p> <ul style="list-style-type: none"> • Check terminals at the vehicle harness connector (both the ECM and harness side) for damage; bent, corroded, and unseated pins or sockets. Check terminal and pin H3 at the ECM and all terminals and pins in the CLS connector. 	<p>Terminals and connectors are okay. →</p> <p>Problem found. →</p>	<p>Go to 16-6.</p> <p>Repair terminals/connectors (para 7-77). Then go to 16-30.</p>
<p>16-6 Check for Open</p> <ul style="list-style-type: none"> • Disconnect the vehicle harness connector at the ECM. • Place the red lead of the volt meter into socket B3 (439) and black lead to a good ground. • Turn ignition on. • Read voltage. 	<p>Less than or equal to 10 volts. →</p> <p>Greater than 10 volts. →</p>	<p>An open exists on the ignition line (ckt #439). Repair open. Then go to 16-30.</p> <p>Replace ECM (para 7-29.1). Then go to 16-30.</p>

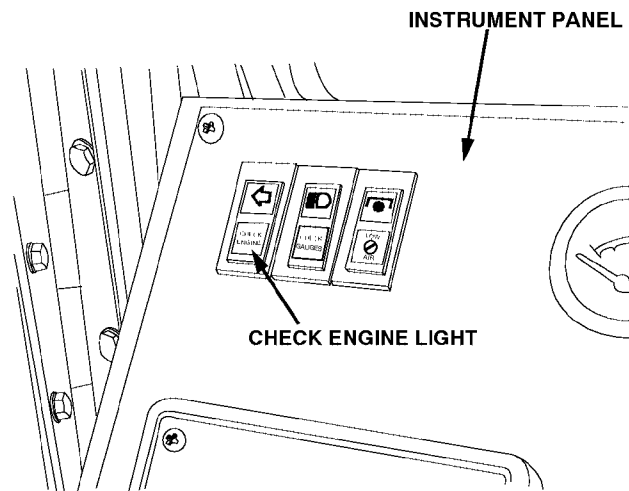

Section 4 TROUBLESHOOTING CHARTS

E. FLASH CODE: 16
 J1587 CODE: P111 3 - COOLANT LEVEL CIRCUIT FAILED HIGH (VOLTAGE HIGH)

STEP/SEQUENCE	RESULT	WHAT TO DO NEXT
<p>16-30 Verify Repairs</p>		
<ul style="list-style-type: none"> • Turn ignition off. • Reconnect all connectors. • Turn ignition on. • Clear codes. • Note status of "Check Engine" light. • If "Check Engine" light does not stay on, start engine and run (TM 9-2320-360-10) until "Check Engine" light comes on or 1 minute. Stop engine. • Read inactive codes. 	<p>No codes. →</p> <p>Code 111/3 (and any other codes). →</p> <p>Any other codes except Code 111/3. →</p>	<p>Repairs are complete.</p> <p>All system diagnostics are complete. Please review this section from the first step to find the error.</p> <p>Go to START-1, pg H-25, to service other codes.</p>

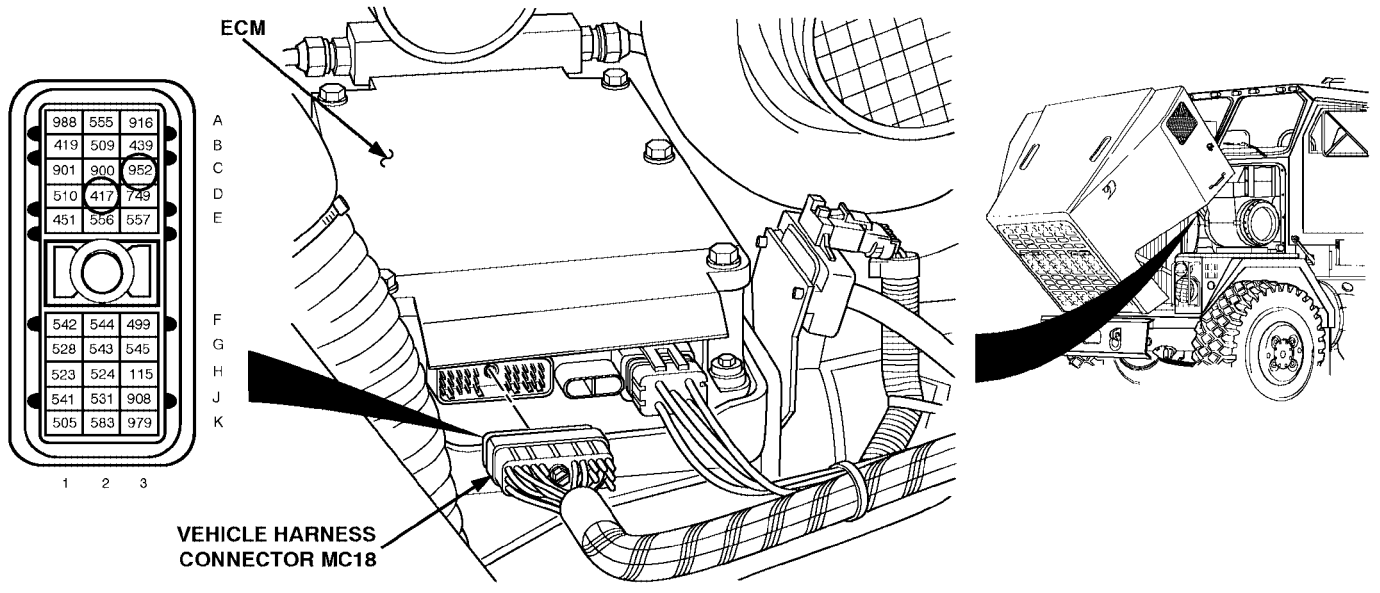
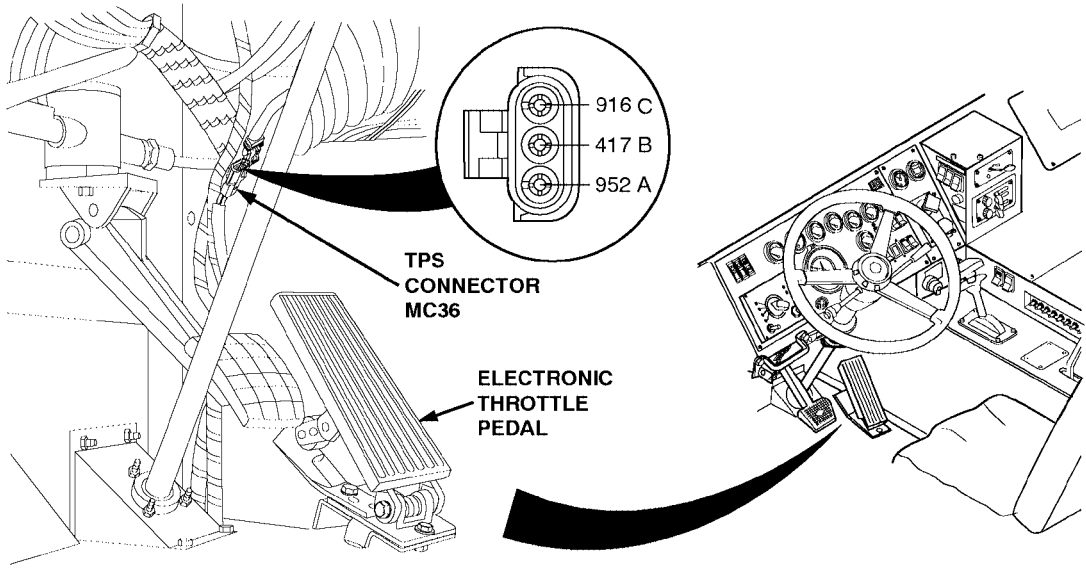

Section 4 TROUBLESHOOTING CHARTS

E. FLASH CODE: 21
J1587 CODE: P91 3 - ELECTRONIC FOOT PEDAL ASM (EPPA) CIRCUIT FAILED HIGH (VOLTAGE HIGH) ALSO CALLED THROTTLE POSITION SENSOR (TPS)

NOTE - This chart is only to be used if:

- 1) All basic mechanical checks and physical inspections have been performed with no problem found, and
- 2) Diagnosis of DDEC-III/IV was started at step START-1, pg H-25 and you have now been referred here.

NOTE - Checks at the TPS connector must be made at MC36, not at the connector on the electronic throttle.

STEP/SEQUENCE	RESULT	WHAT TO DO NEXT
<p>21-5 Multiple Code Check</p> <ul style="list-style-type: none"> • Were there any other active codes besides 91/3? 	<p>No other active codes. →</p> <p>Yes, any or all of the following active codes: 187/3, 91/4. →</p> <p>Yes - But none of the above. →</p>	<p>Go to 21-6.</p> <p>Go to VEH5V-2 (page H-247).</p> <p>Go to 21-6.</p>
<p>21-6 Sensor Check</p> <ul style="list-style-type: none"> • Turn ignition off. • Disconnect TPS connector. • Turn ignition on. • Read active codes. 	<p>Any code (except Code 91/3). →</p> <p>Code 91/3 (and any other codes). →</p>	<p>Go to 21-7.</p> <p>Go to 21-7.</p>
<p>21-7 Return Circuit Check</p> <ul style="list-style-type: none"> • Turn ignition off. • Install a jumper wire between pins A and B of the TPS harness connector. • Disconnect the vehicle harness connector at the ECM. • Read resistance between sockets D2 and C3 on the vehicle harness connector. 	<p>Less than or equal to 5 ohms. →</p> <p>Greater than 5 ohms open. →</p>	<p>Go to 21-8.</p> <p>Return line (ckt #952) and/or signal (ckt #417) is open. Repair open. Then go to 21-30.</p>
<p>21-8 Check TPS Adjustment</p> <ul style="list-style-type: none"> • Reconnect vehicle harness connector and plug TPS back in. • Hook-up DDR to the DDL connector and select TPS CNTS. • Turn ignition on. • Read TPS Counts at both no throttle and full throttle. 	<p>Getting 64-205 counts at no throttle and less than 968 counts at full throttle. →</p> <p>Not getting the above reading. →</p>	<p>Go to 21-6.</p> <p>Replace TPS (Electronic Throttle) (para 7-28). Then go to 21-30.</p>

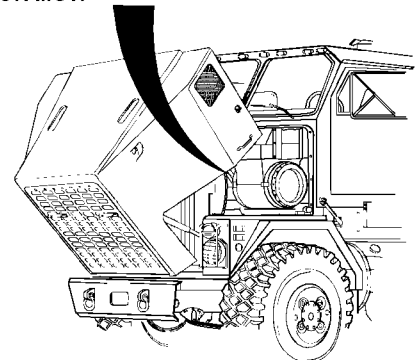
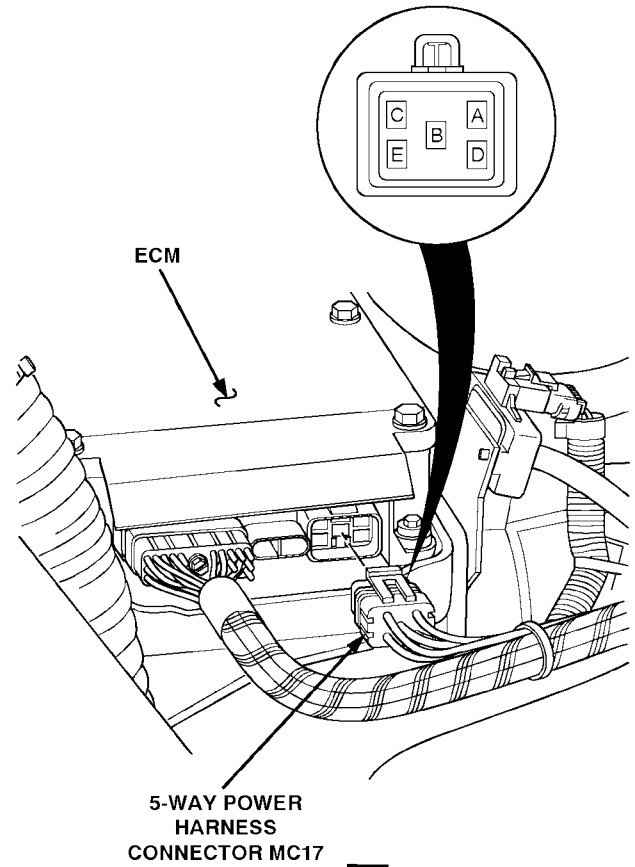
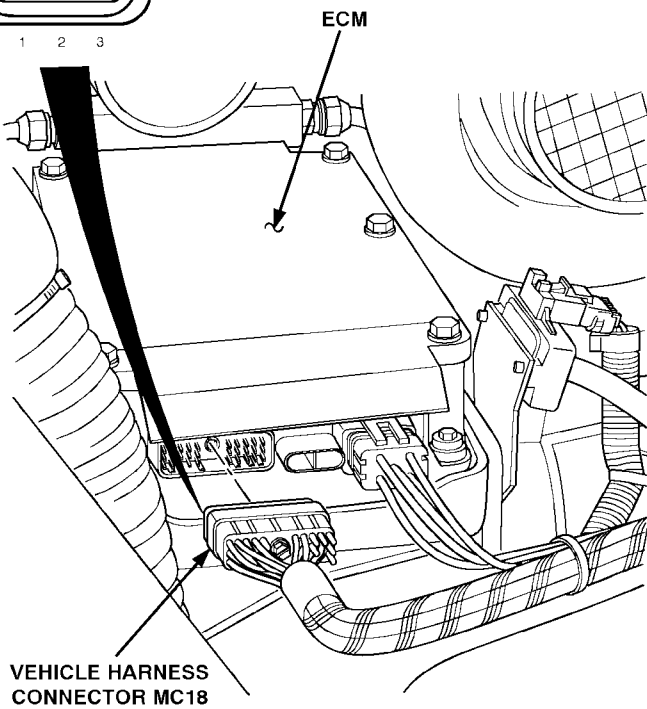
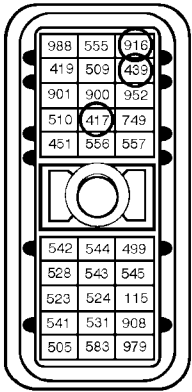
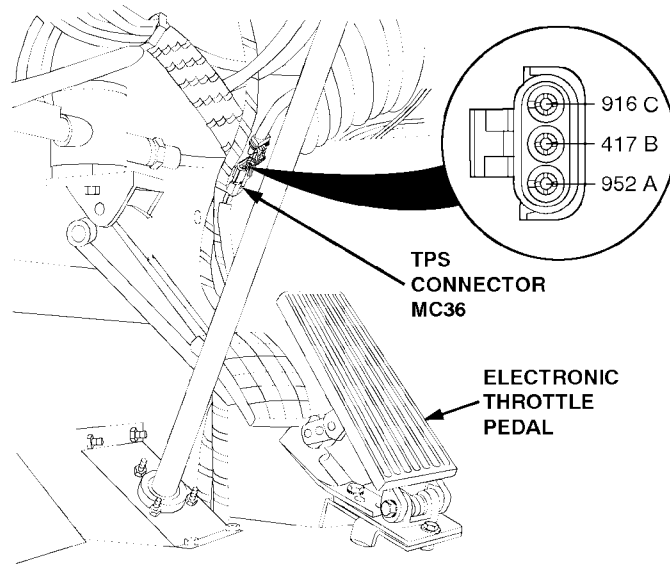

Section 4 TROUBLESHOOTING CHARTS

E. FLASH CODE: 21
J1587 CODE: P91 3 - ELECTRONIC FOOT PEDAL ASM (EFPA) CIRCUIT FAILED HIGH (VOLTAGE HIGH) ALSO CALLED THROTTLE POSITION SENSOR (TPS)

STEP/SEQUENCE	RESULT	WHAT TO DO NEXT
<p>21-5 (Deleted)</p>		
<p>21-6 Check TPS Connectors</p> <ul style="list-style-type: none"> • Inspect terminals at the TPS connectors (sensor side and harness side) for damage; bent, corroded, and unseated pins of sockets. 	<p>Terminals and connectors are okay. →</p> <p>Problem found. →</p>	<p>Replace TPS (Electronic Throttle) (para 7-28). Then go to 21-30.</p> <p>Repair terminals/connectors (para 7-77). Then go to 21-30.</p>
<p>21-7 Check for Short</p> <ul style="list-style-type: none"> • Turn ignition off. • Disconnect the vehicle harness connector at the ECM. • Read resistance between sockets D2 and A3 on the vehicle harness connector. 	<p>Less than or equal to 10,000 ohms. →</p> <p>Greater than 10,000 ohms or open. →</p>	<p>Signal line (ckt #417) is shorted to the vehicle + 5 volt line (ckt #916). Repair short. Then go to 21-30.</p> <p>Go to 21-8.</p>
<p>21-8 Check for Short to Battery +</p> <ul style="list-style-type: none"> • Disconnect batteries (para 7-61). • Disconnect the vehicle harness and 5-way power harness connectors at the ECM. • Read resistance between socket D2 of the vehicle harness connector and socket B3 of the vehicle harness connector. • Also read resistance between socket D2 on the vehicle harness connector and the following sockets on the 5-way power harness connector: A and C. 	<p>All readings are greater than 10,000 ohms or open. →</p> <p>Any reading is less than or equal to 10,000 ohms. →</p>	<p>Go to 21-9.</p> <p>A short exists between the sockets where less than 10,000 ohms resistance was read. Repair short. Then go to 21-30.</p>

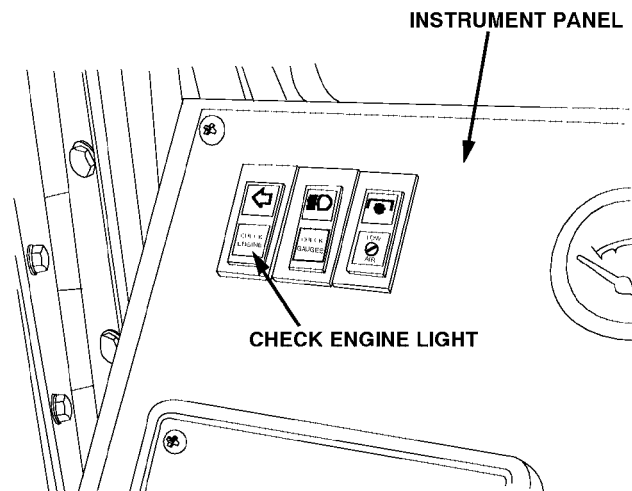
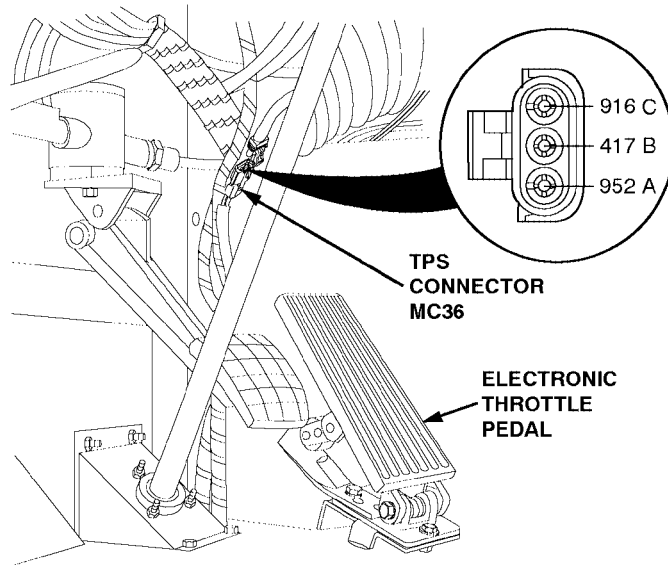

Section 4 TROUBLESHOOTING CHARTS

E. FLASH CODE: 21
 J1587 CODE: P91 3 - ELECTRONIC FOOT PEDAL ASM (EFPA) CIRCUIT FAILED HIGH (VOLTAGE HIGH) ALSO CALLED THROTTLE POSITION SENSOR (TPS)

STEP/SEQUENCE	RESULT	WHAT TO DO NEXT
<p>21-9 Check ECM Connectors</p> <ul style="list-style-type: none"> • Check terminals at the vehicle harness connector (both the ECM and harness side) for damage; bent, corroded and unseated pins or sockets. 	<p>Terminals and connectors are okay. →</p> <p>Problem found. →</p>	<p>Replace ECM (para 7-29.1). Then go to 21-30.</p> <p>Repair terminals/connectors (para 7-77). Then go to 21-30.</p>
<p>21-30 Verify Repairs</p> <ul style="list-style-type: none"> • Turn ignition off. • Reconnect all connectors. • Turn ignition on. • Clear codes. • Note status of "Check Engine" light. • If "Check Engine" light does not stay on, start engine and run (TM 9-2320-360-10) until "Check Engine" light comes on or 1 minute. Stop engine. • Read all codes. 	<p>No codes. →</p> <p>Code 91/3 (and any other codes). →</p> <p>Any other codes except Code 91/3. →</p>	<p>Repairs are complete.</p> <p>All system diagnostics are complete. Please review this section from the first step to find the error.</p> <p>Go to START-1, pg H-25, to service other codes.</p>

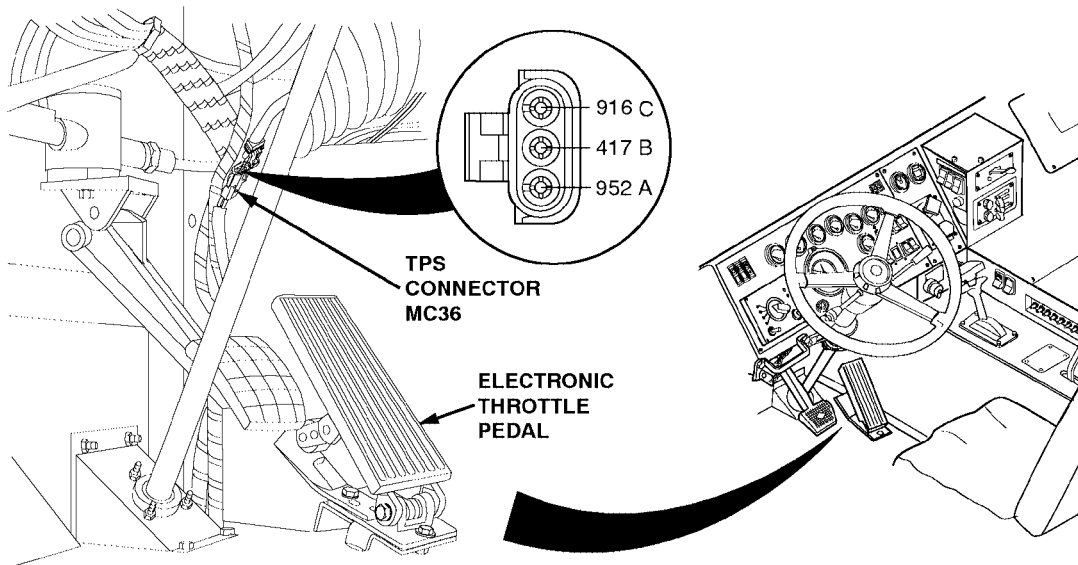

Section 4 TROUBLESHOOTING CHARTS

E. FLASH CODE: 22
J1587 CODE: P91 4 - ELECTRONIC FOOT PEDAL ASM (EFPA) CIRCUIT FAILED LOW (VOLTAGE LOW) ALSO CALLED THROTTLE POSITION SENSOR (TPS)

NOTE - This chart is only to be used if:

- 1) All basic mechanical checks and physical inspections have been performed with no problem found, and
- 2) Diagnosis of DDEC-III/IV was started at step START-1, pg H-25 and you have now been referred here.

NOTE - Checks at the TPS connector must be made at MC36, not at the connector on the electronic throttle.

STEP/SEQUENCE	RESULT	WHAT TO DO NEXT
22-1 Multiple Code Check		
<ul style="list-style-type: none"> • Were there any other active codes besides 91/4? 	<p>No other active codes. → Go to 22-2.</p> <p>Yes, any or all of the following codes: 187/3, 91/3. → Go to VEH5V-2 (page H-247).</p> <p>Yes - But none of the above. → Go to 22-2.</p>	
22-2 Sensor Check		
<ul style="list-style-type: none"> • Turn ignition off. • Disconnect the TPS connector. • Install a jumper wire between sockets B and C of the TPS harness connector. • Turn ignition on. • Read active codes. 	<p>Code 91/4 and/or other codes. → Go to 22-6.</p> <p>Code 91/3 (and any other codes). → Go to 22-3.</p>	
22-3 Check TPS Adjustment		
<ul style="list-style-type: none"> • Remove jumper and reconnect TPS. • Hook-up DDR to the DDL connector and select TPS CNTS. • Read TPS Counts at both no throttle and full throttle. 	<p>Getting 64-205 counts at no throttle and less than 968 counts at full throttle. → Go to 22-5.</p> <p>Not getting the above readings. → Replace TPS (Electronic Throttle) (para 7-28). Then go to 22-30.</p>	

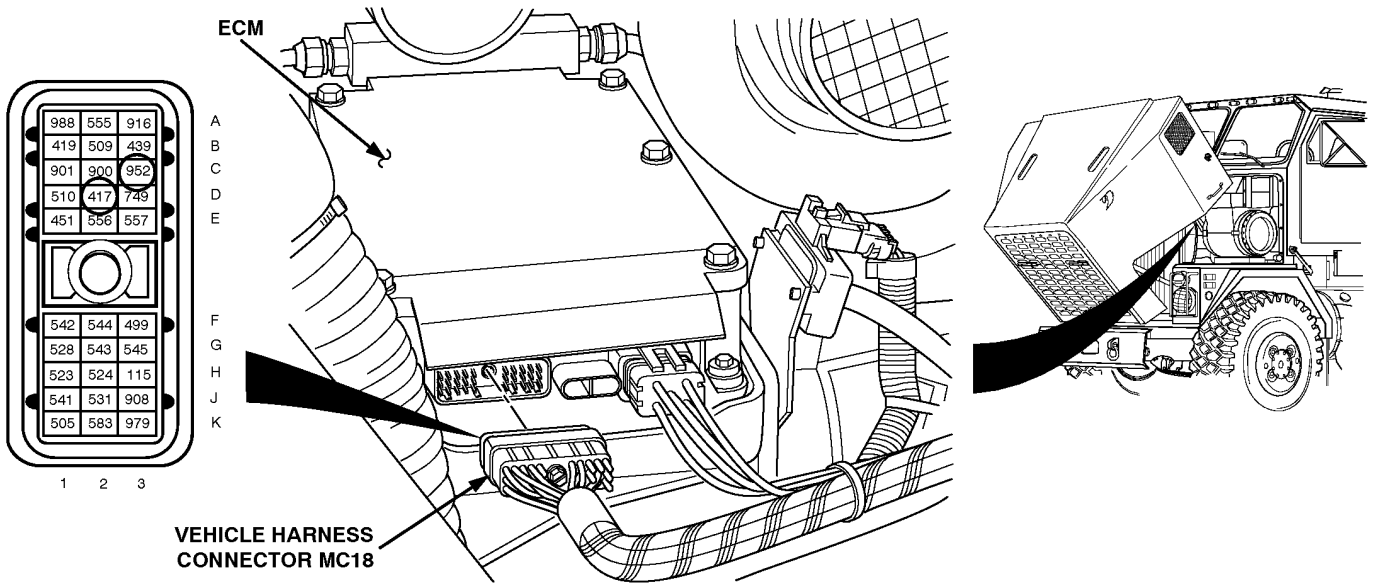
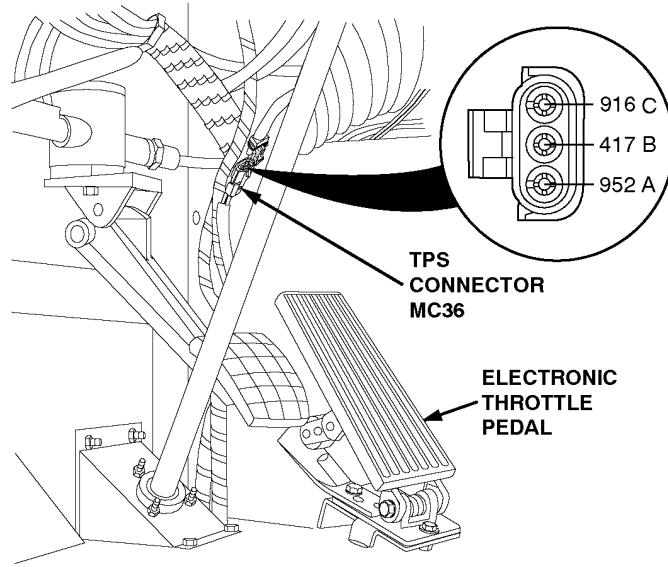

Section 4 TROUBLESHOOTING CHARTS

E. FLASH CODE: 22
J1587 CODE: P91 4 - ELECTRONIC FOOT PEDAL ASM (EFPA) CIRCUIT FAILED HIGH (VOLTAGE HIGH) ALSO CALLED THROTTLE POSITION SENSOR (TPS)

STEP/SEQUENCE	RESULT	WHAT TO DO NEXT
22-4 (Deleted)		
22-5 Check TPS Connectors		
<ul style="list-style-type: none"> • Inspect terminals at the TPS connectors (sensor side and harness side) for damage, corrosion, and unseated pins or sockets. 	Terminals and connectors are okay.	Replace TPS (Electronic Throttle) (para 7-28). Then go to 22-30.
	Problem found.	Repair terminals/connectors (para 7-77). Then go to 22-30.
22-6 Check for +5 Volts		
<ul style="list-style-type: none"> • Turn ignition off. • Remove jumper • Turn ignition on. • Read voltage on TPS connector, socket C (red lead) to socket A (black lead). 	Between 4 to 6 volts.	Go to 22-7.
	Less than 4 volts.	Go to 22-10.
	Greater than 6 volts.	Go to 22-12.
22-7 Check for Short		
<ul style="list-style-type: none"> • Turn ignition off. • Disconnect the vehicle harness connector at ECM. • Read resistance between sockets A and B on the TPS connector. • Also read resistance between socket B of TPS connector and a good ground. 	Less than or equal to 10,000 ohms on either reading.	Signal line (ckt #417) is shorted to the return line (ckt #952) or battery ground. Repair short. Then go to 22-30.
	Greater than 10,000 ohms or open on both readings.	Go to 22-8.

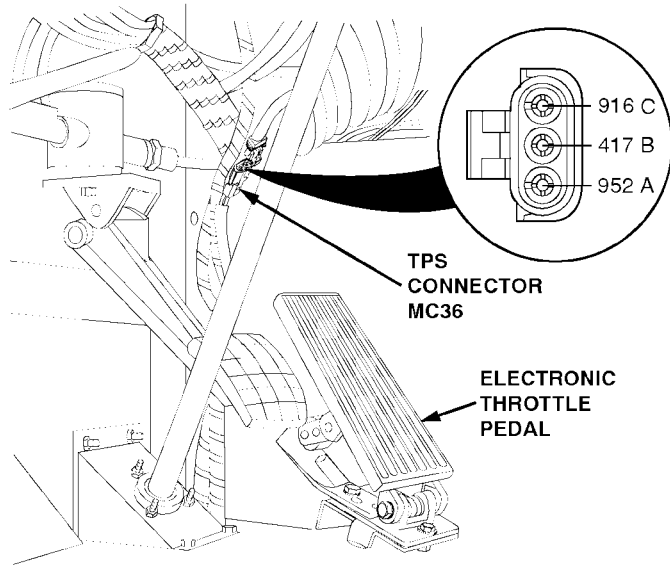
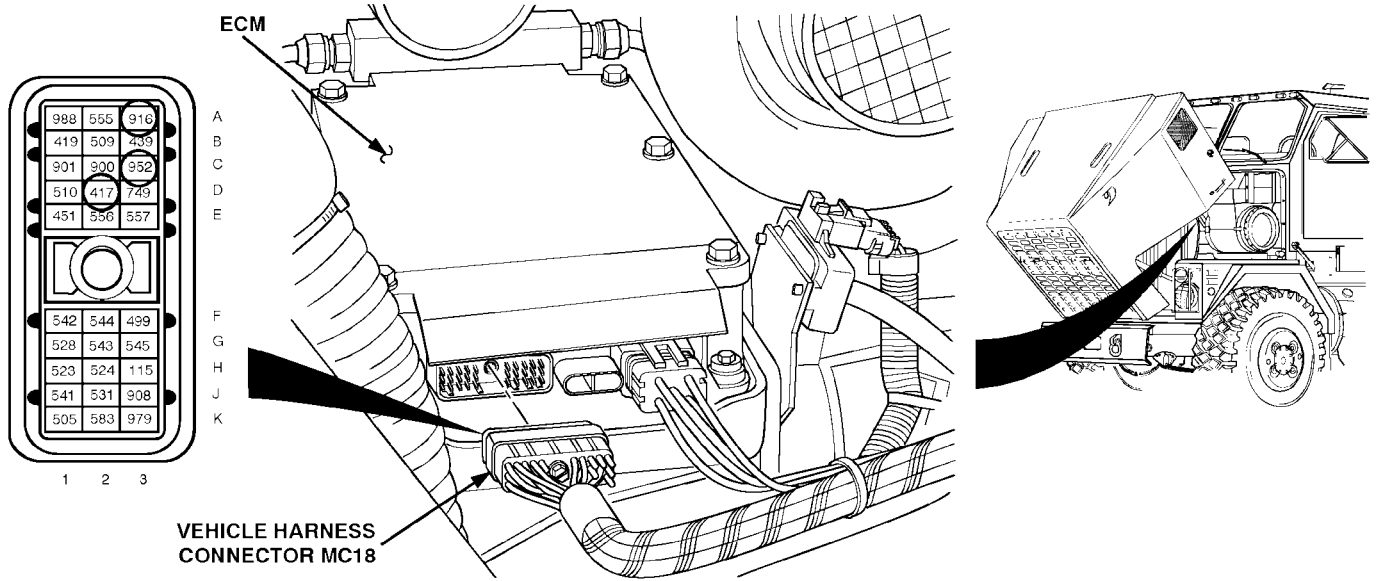

Section 4 TROUBLESHOOTING CHARTS

E. FLASH CODE: 22
J1587 CODE: P91 4 - ELECTRONIC FOOT PEDAL ASM (EFPA) CIRCUIT FAILED HIGH (VOLTAGE HIGH) ALSO CALLED THROTTLE POSITION SENSOR (TPS)

STEP/SEQUENCE	RESULT	WHAT TO DO NEXT
<p>22-8 Check for Signal Open</p> <ul style="list-style-type: none"> • Install a jumper wire between sockets A and B of the TPS connector. • Read resistance between sockets D2 and C3 on the vehicle harness connector. 	<p>Less than _____ or equal to 5 ohms. →</p> <p>Greater than 5 ohms or open. →</p>	<p>Go to 22-9.</p> <p>Signal line (ckt # 417) is open. and/or signal return (ckt #952) is open. Repair open. If no open was found, check ECM terminals A3, D2, C3, and TPS pins. Then go to 22-30.</p>
<p>22-9 Check ECM Connectors</p> <ul style="list-style-type: none"> • Check terminals at the vehicle harness connector (both the ECM and harness side) for damage; bent, corroded, and unseated pins or sockets. 	<p>Terminals and connectors are okay. →</p> <p>Problem found. →</p>	<p>Replace ECM (para 7-29.1). Then go to 22-30.</p> <p>Repair terminals/connectors (para 7-77). Then go to 22-30.</p>
<p>22-10 Check for Short</p> <ul style="list-style-type: none"> • Turn ignition off. • Disconnect the vehicle harness connector at the ECM. • Read resistance between sockets A and C on the TPS connector. 	<p>Less than or equal to 10,000 ohms. →</p> <p>Greater than 10,000 ohms or open. →</p>	<p>The vehicle +5 volt line (ckt #916) is shorted to the return line (ckt #952). Repair short. Then go to 22-30.</p> <p>Go to 22-11.</p>
<p>22-11 Check for Open +5 Volt Line</p> <ul style="list-style-type: none"> • Install a jumper wire between sockets A and C of the TPS connector. • Read resistance between sockets A3 and C3 on the vehicle harness connector. 	<p>Less than or equal to 5 ohms. →</p> <p>Greater than 5 ohms or open. →</p>	<p>Go to 22-9.</p> <p>The vehicle +5 volt line (ckt #916) is open. Repair open. Then go to 22-30.</p>

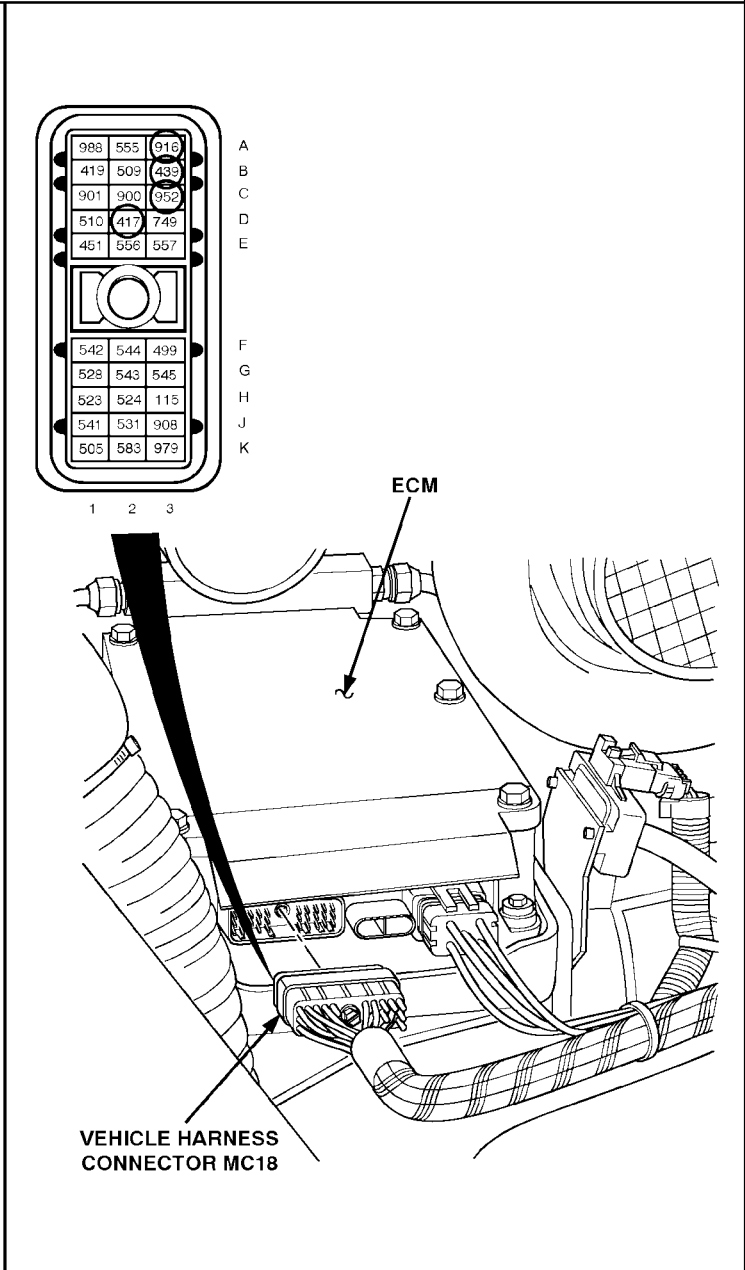
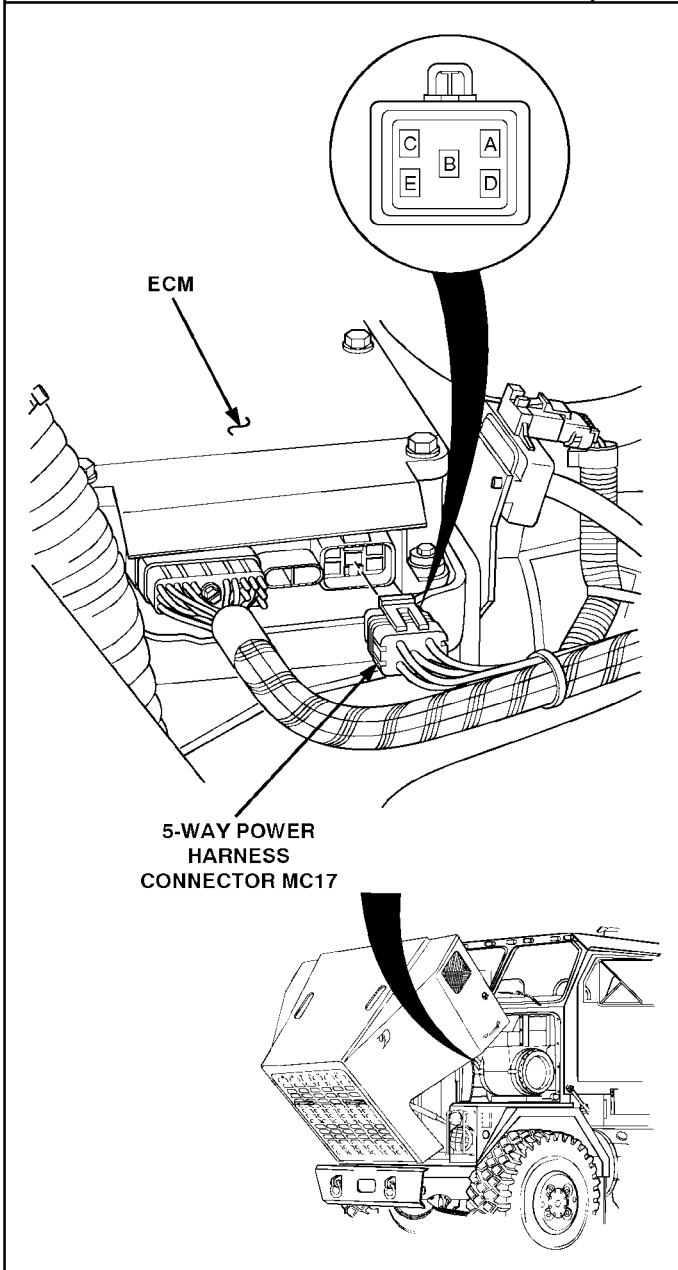
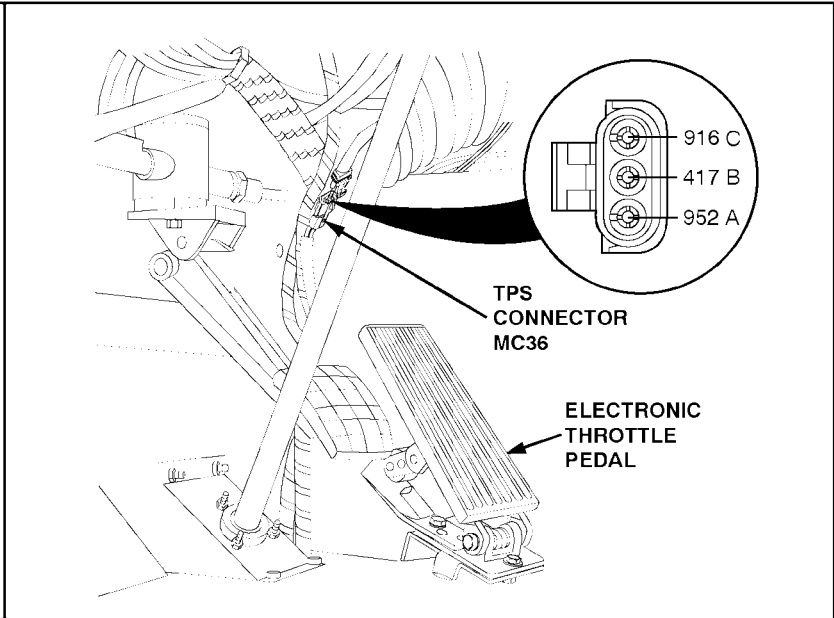
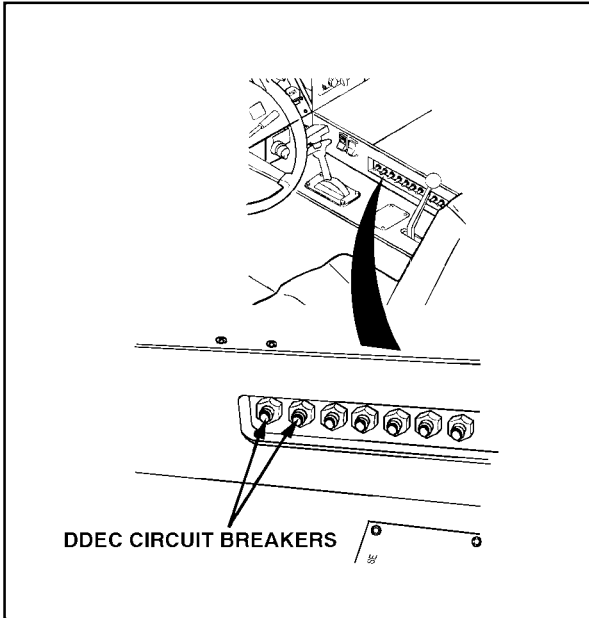

Section 4 TROUBLESHOOTING CHARTS

E. FLASH CODE: 22
J1587 CODE: P91 4 - ELECTRONIC FOOT PEDAL ASM (EFPA) CIRCUIT FAILED HIGH (VOLTAGE HIGH) ALSO CALLED THROTTLE POSITION SENSOR (TPS)

STEP/SEQUENCE	RESULT	WHAT TO DO NEXT
<p>22-12 Check for Short to Battery +</p> <ul style="list-style-type: none"> • Turn ignition off. • Disconnect batteries (para 7-61). • Disconnect 5-way power harness connector at the ECM. • Read resistance between sockets D2 and B3 on the vehicle harness connector. • Also read resistance between socket D2 on the vehicle harness connector and the following sockets on the 5-way power harness connector: B, C, D, & E. • Connect batteries (para 7-61). 	<p>All readings are greater than 10,000 ohms or open. →</p> <p>Any reading is less than or equal to 10,000 ohms. →</p>	<p>Go to 22-13.</p> <p>A short exists between sockets where less than 10,000 ohms resistance was read. Repair short and reset circuit breakers. Then go to 22-30.</p>
<p>22-13 Check for Outside DDEC Battery +</p> <ul style="list-style-type: none"> • Turn ignition off. • Remove ECM 5-way power harness connectors. • Remove vehicle harness connector. • Turn ignition on. • Read voltage A3 (red lead) to a good ground (black lead). • Read voltage C3 (red lead) to a good ground (black lead). 	<p>All readings less than 4.0 volts. →</p> <p>Either reading greater than or equal to 4.0 volts. →</p>	<p>Go to 22-9.</p> <p>Outside power is shorted to either (ckt #952) or (ckt #916). Repair short. Then go to 22-30.</p>
<p>22-30 Verify Repairs</p> <ul style="list-style-type: none"> • Turn ignition off. • Reconnect all connectors. • Turn ignition on. • Clear codes. • Note status of "Check Engine" light. • If "Check Engine" light does not stay on, start engine and run (TM 9-2320-360-10) until "Check Engine" light comes on or 1 minute. Stop engine. • Read all codes. 	<p>No codes. →</p> <p>Code 91/4 (and any other codes). →</p> <p>Any other codes except Code 91/4. →</p>	<p>Repairs are complete.</p> <p>All system diagnostics are complete. Please review this section from the first step to find the error.</p> <p>Go to START-1, pg H-25, to service other codes.</p>

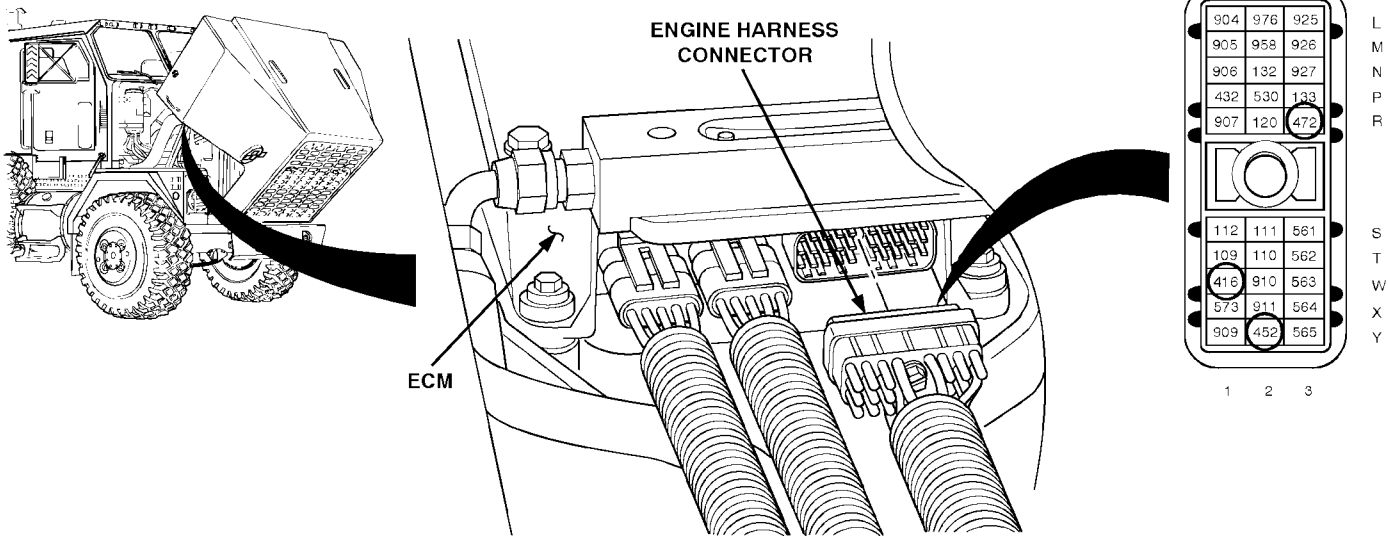
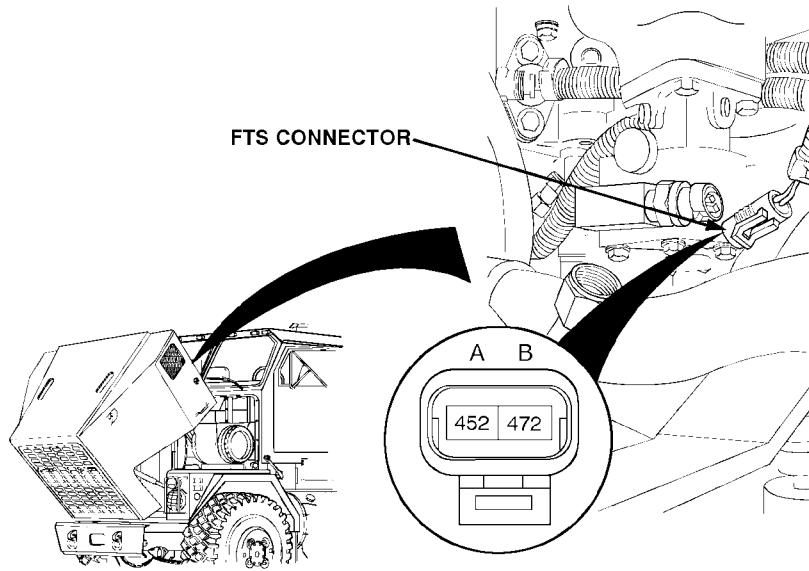

Section 4 TROUBLESHOOTING CHARTS

E. FLASH CODE: 23
J1587 CODE: P174 3 - FUEL TEMPERATURE CIRCUIT FAILED HIGH (HIGH VOLTAGE)

NOTE - This chart is only to be used if:

- 1) All basic mechanical checks and physical inspections have been performed with no problem found, and
- 2) Diagnosis of DDEC-III/IV was started at step START-1, pg H-25 and you have now been referred here.

STEP/SEQUENCE	RESULT	WHAT TO DO NEXT
<p>23-1 Sensor Check</p> <ul style="list-style-type: none"> • Turn ignition off. • Disconnect FTS connector and install a jumper wire between the FTS connector sockets A and B. • Turn ignition on. • Read active codes. 	<p>Code 174/4 and/or any codes except Code 174/3. → Go to 23-2.</p> <p>Anything except Code 174/4. → Go to 23-4.</p>	
<p>23-2 Check for Short to +5 Volt Line</p> <ul style="list-style-type: none"> • Turn ignition off. • Remove jumper wire. • Disconnect the engine harness connector at the ECM. • Read resistance between sockets R3 and W1 on the engine harness connector. 	<p>Less than or equal to 10,000 ohms. → Signal line (ckt #472) is shorted to the engine +5 volt line (ckt #416), and/or (ckt #472) signal is shorted to (ckt #452) sensor return and/or ground. Repair short. Then go to 23-30.</p> <p>Greater than 10,000 ohms or open. → Go to 23-3.</p>	
<p>23-3 Check FTS Connectors</p> <ul style="list-style-type: none"> • Inspect terminals at the FTS connectors (both the sensor and harness side) for damage; bent, corroded, and unseated pins or sockets. 	<p>Terminals and connectors are okay. → Replace FTS (para 7-33). Then go to 23-30.</p> <p>Problem found. → Repair terminals/connectors (para 7-77). Then go to 23-30.</p>	
<p>23-4 Open Line Check</p> <ul style="list-style-type: none"> • Turn ignition off. • Disconnect the engine harness connector at the ECM. • Read resistance between sockets R3 and Y2 on the engine harness connector. 	<p>Less than or equal to 5 ohms. → Go to 23-5.</p> <p>Greater than 5 ohms or open. → Signal line (ckt #472) or return line (ckt #452) is open. Repair open. Then go to 23-30.</p>	

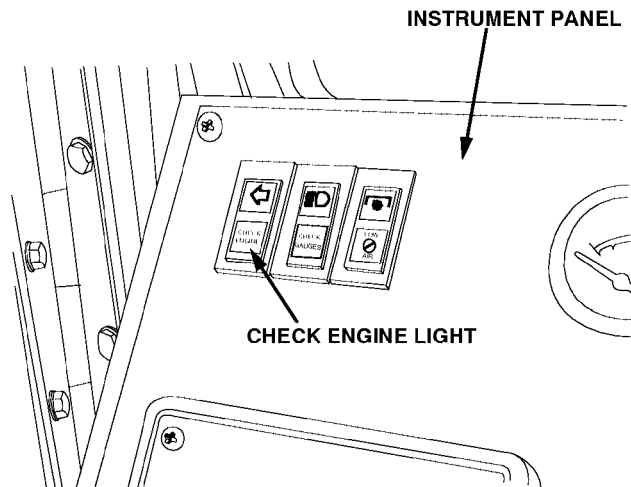
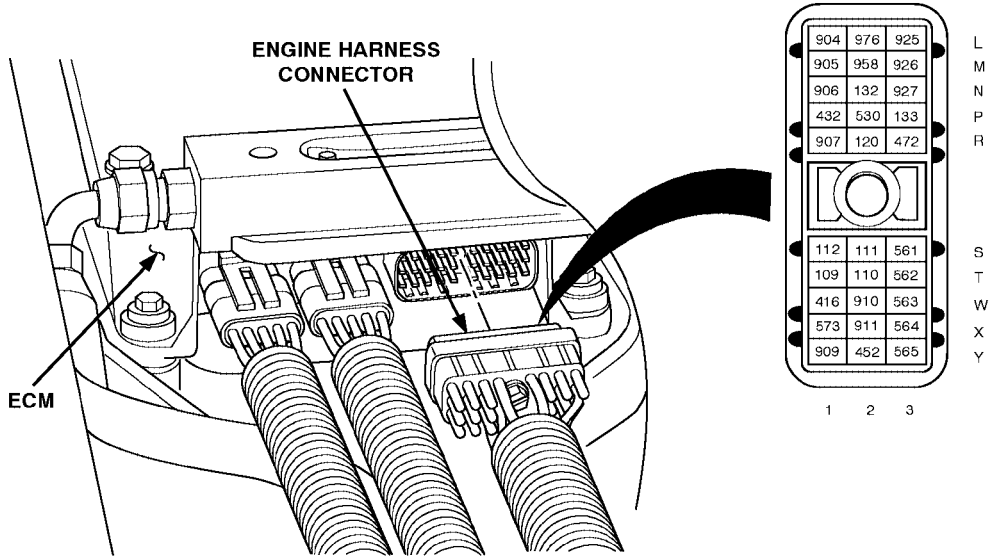

Section 4 TROUBLESHOOTING CHARTS

E. FLASH CODE: 23
 J1587 CODE: P174 3 - FUEL TEMPERATURE CIRCUIT FAILED HIGH (HIGH VOLTAGE)

STEP/SEQUENCE	RESULT	WHAT TO DO NEXT
<p>23-5 Check ECM Connectors</p> <ul style="list-style-type: none"> • Check terminals at the engine harness connector (both the ECM and harness side) for damage; bent, corroded, and unseated pins or sockets. 	<p>Terminals and connectors are okay. →</p> <p>Problem found. →</p>	<p>Replace ECM (para 7-29.1). Then go to 23-30.</p> <p>Repair terminals/connectors (para 7-77). Then go to 23-30.</p>
<p>23-30 Verify Repairs</p> <ul style="list-style-type: none"> • Turn ignition off. • Reconnect all connectors. • Turn ignition on. • Clear codes. • Note status of "Check Engine" light. • If "Check Engine" light does not stay on, start engine and run (TM 9-2320-360-10) until "Check Engine" light comes on or 8 minutes. Stop engine. • Read inactive codes. 	<p>No codes. →</p> <p>Code 174/3 (and any other codes). →</p> <p>Any other codes except Code 174/3. →</p>	<p>Repairs are complete.</p> <p>All system diagnostics are complete. Please review this section from the first step to find the error.</p> <p>Go to START-1, pg H-25, to service other codes.</p>

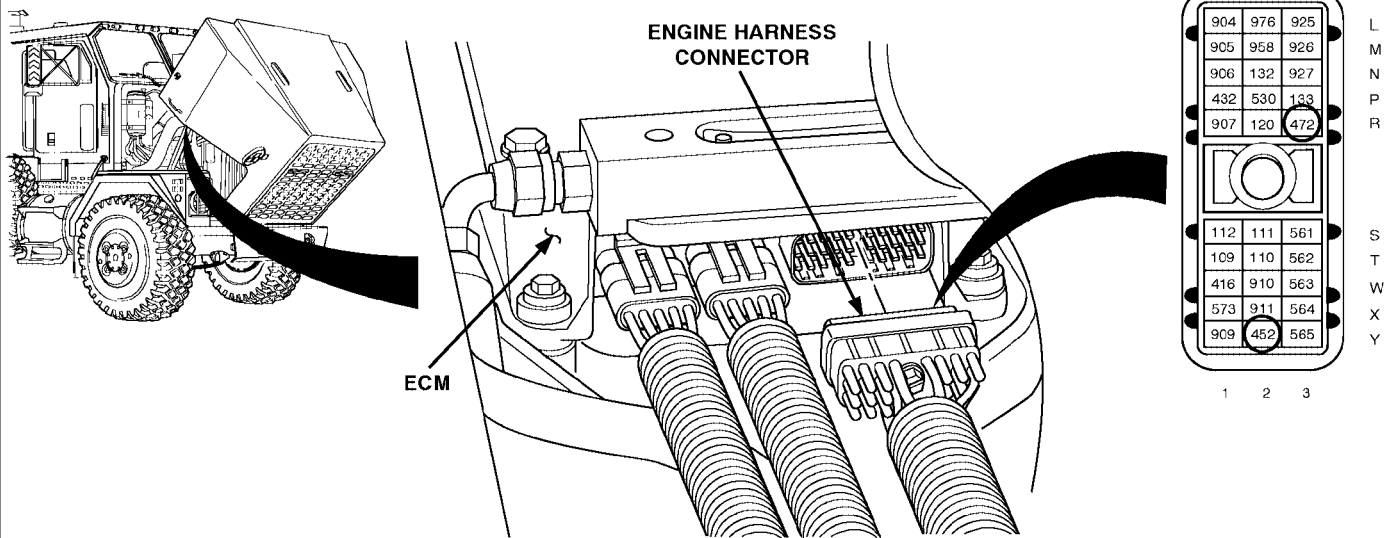
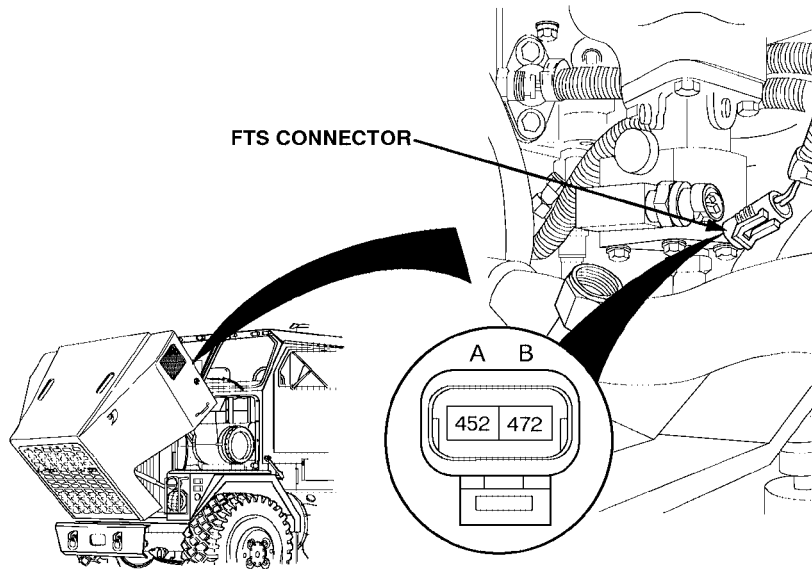

Section 4 TROUBLESHOOTING CHARTS

E. FLASH CODE: 24
J1587 CODE: P174 4 - FUEL TEMPERATURE CIRCUIT FAILED LOW (LOW VOLTAGE)

NOTE - This chart is only to be used if:

- 1) All basic mechanical checks and physical inspections have been performed with no problem found, and
- 2) Diagnosis of DDEC-III/IV was started at step START-1, pg H-25 and you have now been referred here.

STEP/SEQUENCE	RESULT	WHAT TO DO NEXT
24-1 Multiple Code Check		
<ul style="list-style-type: none"> • Were there any other active codes besides Code 174/4? 	<p>No other codes. →</p> <p>Yes, any or all of the following codes: 110/3, 175/3, 174/3, 102/3, 187/4, 91/4, 100/4, 102/4, 110/4, 175/4. →</p> <p>Yes - but none of the above. →</p>	<p>Go to 24-2.</p> <p>Go to VEH5V-2 (page H-247).</p> <p>Go to 24-2.</p>
24-2 Sensor Check		
<ul style="list-style-type: none"> • Turn ignition off. • Disconnect FTS connector. • Start engine and run (TM 9-2320-360-10) until "Check Engine" light comes on or for 8 minutes. • Read active codes with engine still running. 	<p>Code 174/3 (or any other codes except Code 174/4). →</p> <p>Code 174/4 (and any other codes). →</p>	<p>Go to 24-3.</p> <p>Go to 24-4.</p>
24-3 Check FTS Connectors		
<ul style="list-style-type: none"> • Inspect terminals at the FTS connectors (both the sensor and harness side) for damage; bent, corroded, and unseated pins or sockets. 	<p>Terminals and connectors are okay. →</p> <p>Problem found. →</p>	<p>Replace FTS (para 7-33). Then go to 24-30.</p> <p>Repair terminals/connectors (para 7-77). Then go to 24-30.</p>
24-4 Open Line Check		
<ul style="list-style-type: none"> • Turn ignition off. • Disconnect the engine harness connector at the ECM. • Read resistance between sockets R3 and Y2 on the engine harness connector. • Also read resistance between socket B of FTS connector and a good ground. 	<p>Less than or equal to 10,000 ohms on either reading. →</p> <p>Greater than 10,000 ohms or open on both readings. →</p>	<p>Signal line (ckt #472) is shorted to the return line (ckt #452) or battery ground. Repair short. Then go to 24-30.</p> <p>Go to 24-5.</p>

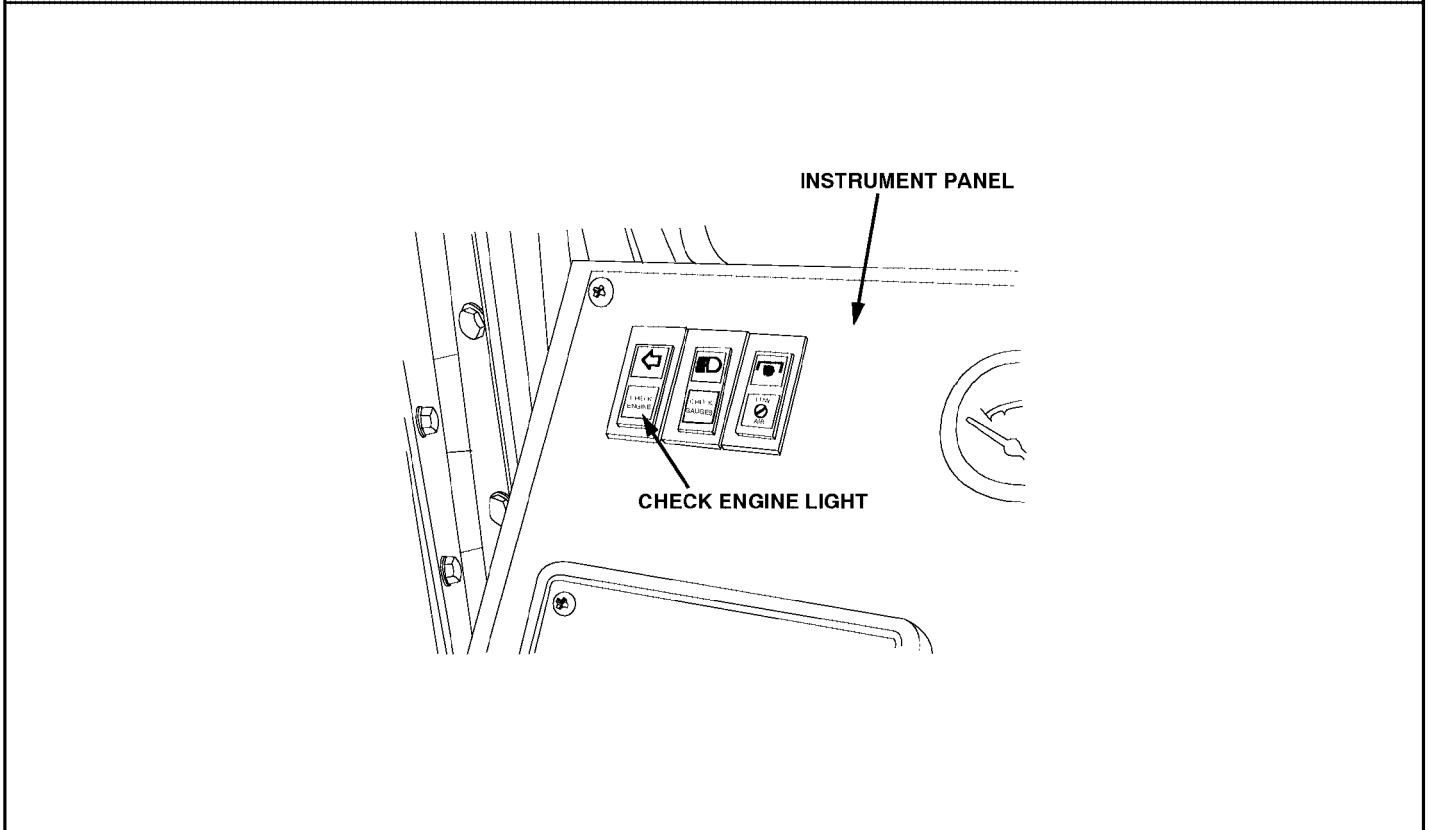
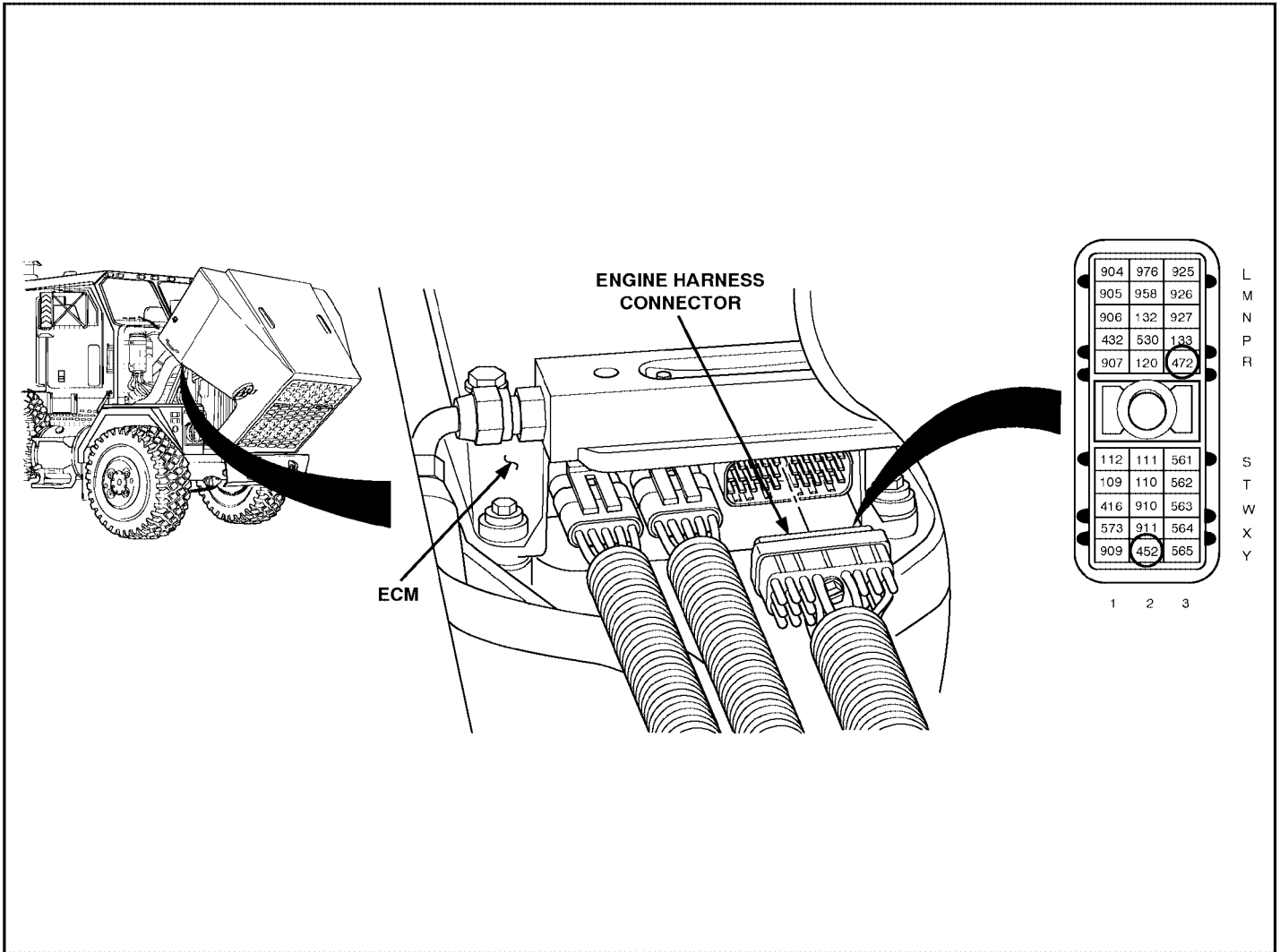

Section 4 TROUBLESHOOTING CHARTS

E. FLASH CODE: 24
 J1587 CODE: P174 4 - FUEL TEMPERATURE CIRCUIT FAILED LOW (LOW VOLTAGE)

STEP/SEQUENCE	RESULT	WHAT TO DO NEXT
<p>24-5 Check ECM Connectors</p> <ul style="list-style-type: none"> • Check terminals at the engine harness connector (both the ECM and harness side) for damage; bent, corroded, and unseated pins or sockets. Especially R3 and Y2 of the engine harness connector. 	<p>Terminals and connectors are okay. →</p> <p>Problem found. →</p>	<p>Replace ECM (para 7-29.1). Then go to 24-30.</p> <p>Repair terminals/connectors (para 7-77). Then go to 24-30.</p>
<p>24-30 Verify Repairs</p> <ul style="list-style-type: none"> • Turn ignition off. • Reconnect all connectors. • Turn ignition on. • Clear codes. • Note status of "Check Engine" light. • If "Check Engine" light does not stay on, start engine and run (TM 9-2320-360-10) until "Check Engine" light comes on or 8 minutes. Stop engine. • Read inactive codes. 	<p>No codes. →</p> <p>Code 174/4 (and any other codes). →</p> <p>Any other codes except Code 174/4. →</p>	<p>Repairs are complete.</p> <p>All system diagnostics are complete. Please review this section from the start to find the error.</p> <p>Go to START-1, pg H-25, to service other codes.</p>

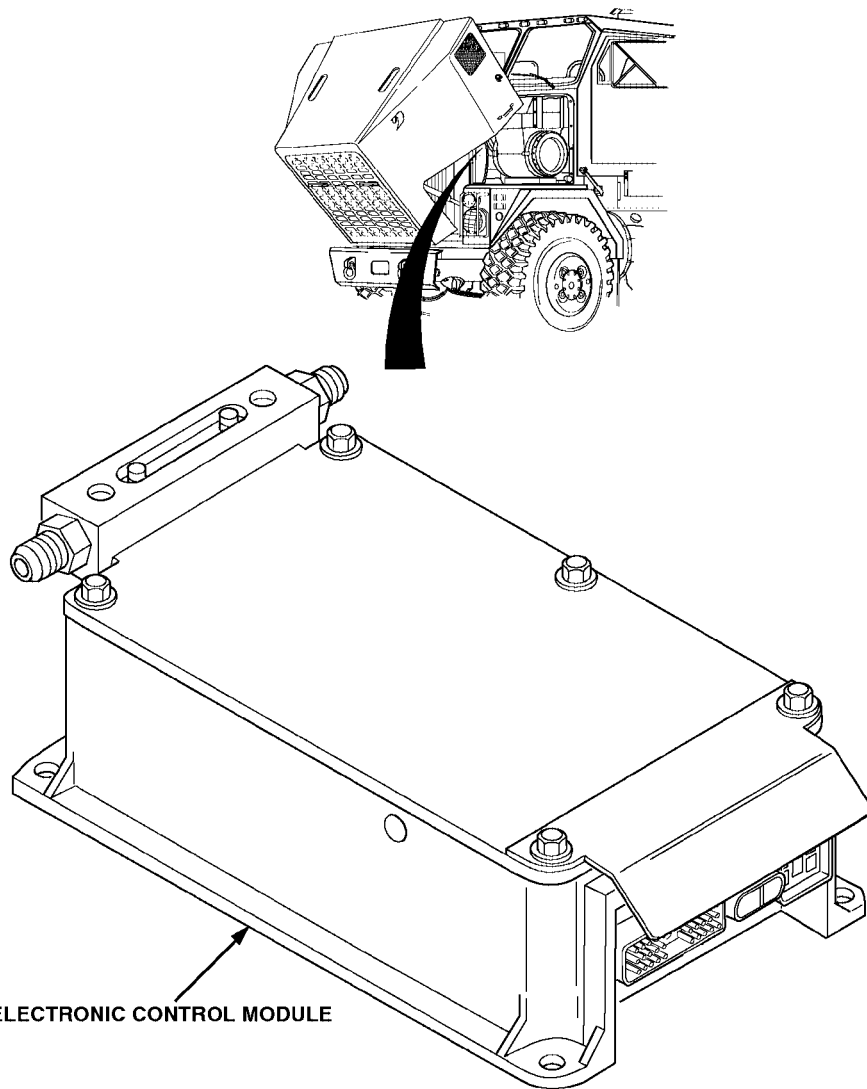

ELECTRONIC CONTROL MODULE

ECM SHOWN REMOVED FOR CLARITY

Section 4

TROUBLESHOOTING CHARTS

E. FLASH CODE: 25
J1587 CODE: NONE NO CODES

NOTE - This chart is only to be used if:

- 1) All basic mechanical checks and physical inspections have been performed with no problem found, and
- 2) Diagnosis of DDEC-III/IV was started at step START-10, pg H-25 and you have now been referred here.

No faults have been detected by DDEC-III/IV since the last time the codes were cleared. If symptoms remain, and all basic mechanical and visual inspections have been performed with no causes to the problem found, you can try using Chart 1 (Intermittent Code or a Symptom and No Codes) on Page H-40.

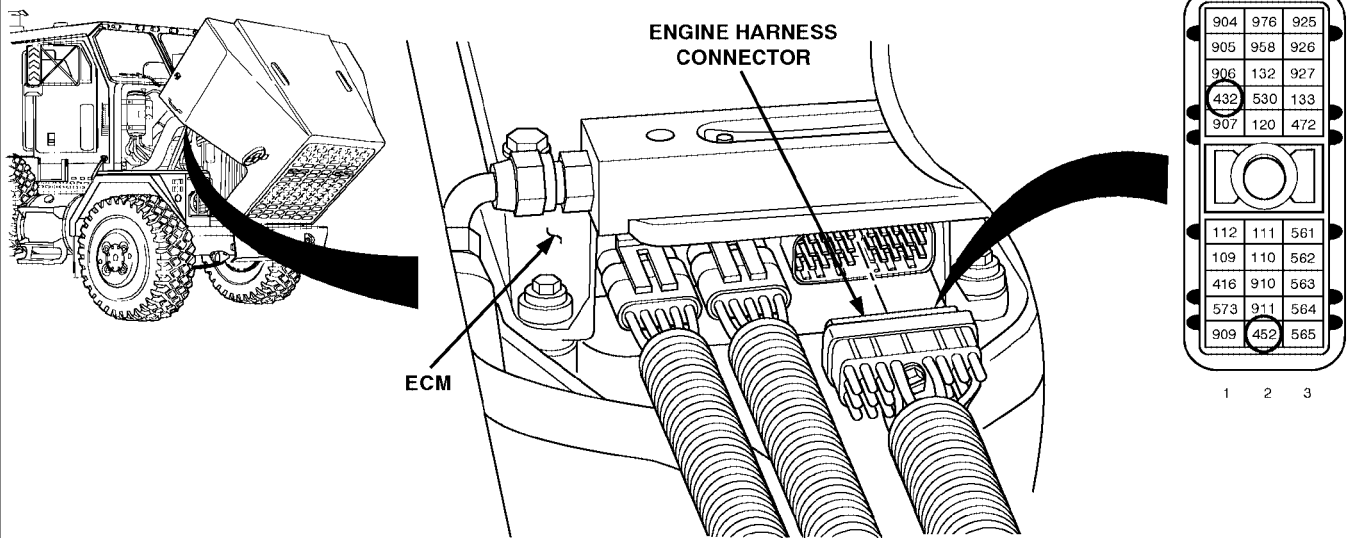
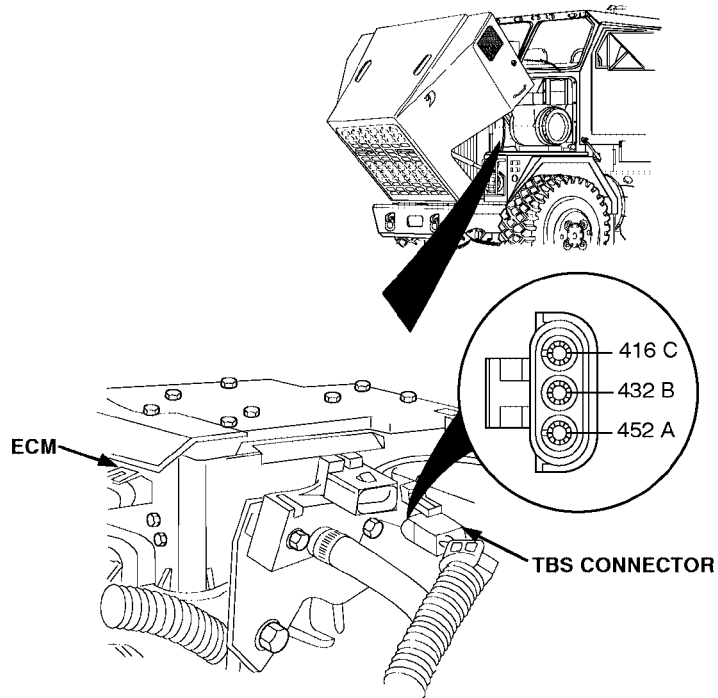

Section 4 TROUBLESHOOTING CHARTS

E. FLASH CODE: 33
J1587 CODE: P102 3 - TURBO BOOST PRESSURE CIRCUIT FAILED HIGH (HIGH VOLTAGE)

NOTE - This chart is only to be used if:

- 1) All basic mechanical checks and physical inspections have been performed with no problem found, and
- 2) Diagnosis of DDEC-III/IV was started at step START-10, pg H-25 and you have now been referred here.

STEP/SEQUENCE	RESULT	WHAT TO DO NEXT
<p>33-1 Multiple Code Check</p> <ul style="list-style-type: none"> • Were there any other active codes besides Code 102/3? 	<p>No other codes. →</p> <p>Yes, any or all of the following codes: 110/3 or 4, 175/3 or 4, 174/3 or 4, 100/3 or 4. →</p> <p>Yes - but none of the above. →</p>	<p>Go to 33-2.</p> <p>Go to ENG5V-2 (pg H-241).</p> <p>Go to 33-2.</p>
<p>33-2 Sensor Check</p> <ul style="list-style-type: none"> • Turn ignition off. • Disconnect TBS connector. • Start and run engine at idle (TM 9-2320-360-10). • Read active codes with engine running. 	<p>Code 102/4 (and any codes except Code 102/3). →</p> <p>Code 102/3 (and any other codes). →</p>	<p>Go to 33-3.</p> <p>Go to 33-5.</p>
<p>33-3 Return Circuit Check</p> <ul style="list-style-type: none"> • Turn ignition off. • Install a jumper wire between pins A and B of the TBS connector. • Disconnect engine harness connector at the ECM. • Read resistance between sockets P1 and Y2 on the engine harness connector. 	<p>Less than or equal to 5 ohms. →</p> <p>Greater than 5 ohms or open. →</p>	<p>Go to 33-4.</p> <p>Return line (ckt #452) is open. Repair open. Then go to 33-30.</p>
<p>33-4 Check TBS Connectors</p> <ul style="list-style-type: none"> • Inspect terminals at the TBS connectors (both the sensor and harness side) for damage; bent, corroded, and unseated pins or sockets. 	<p>Terminals and connectors are okay. →</p> <p>Problem found. →</p>	<p>Replace TBS (para 7-36). Then go to 33-30.</p> <p>Repair terminals/connectors (para 7-77). Then go to 33-30.</p>

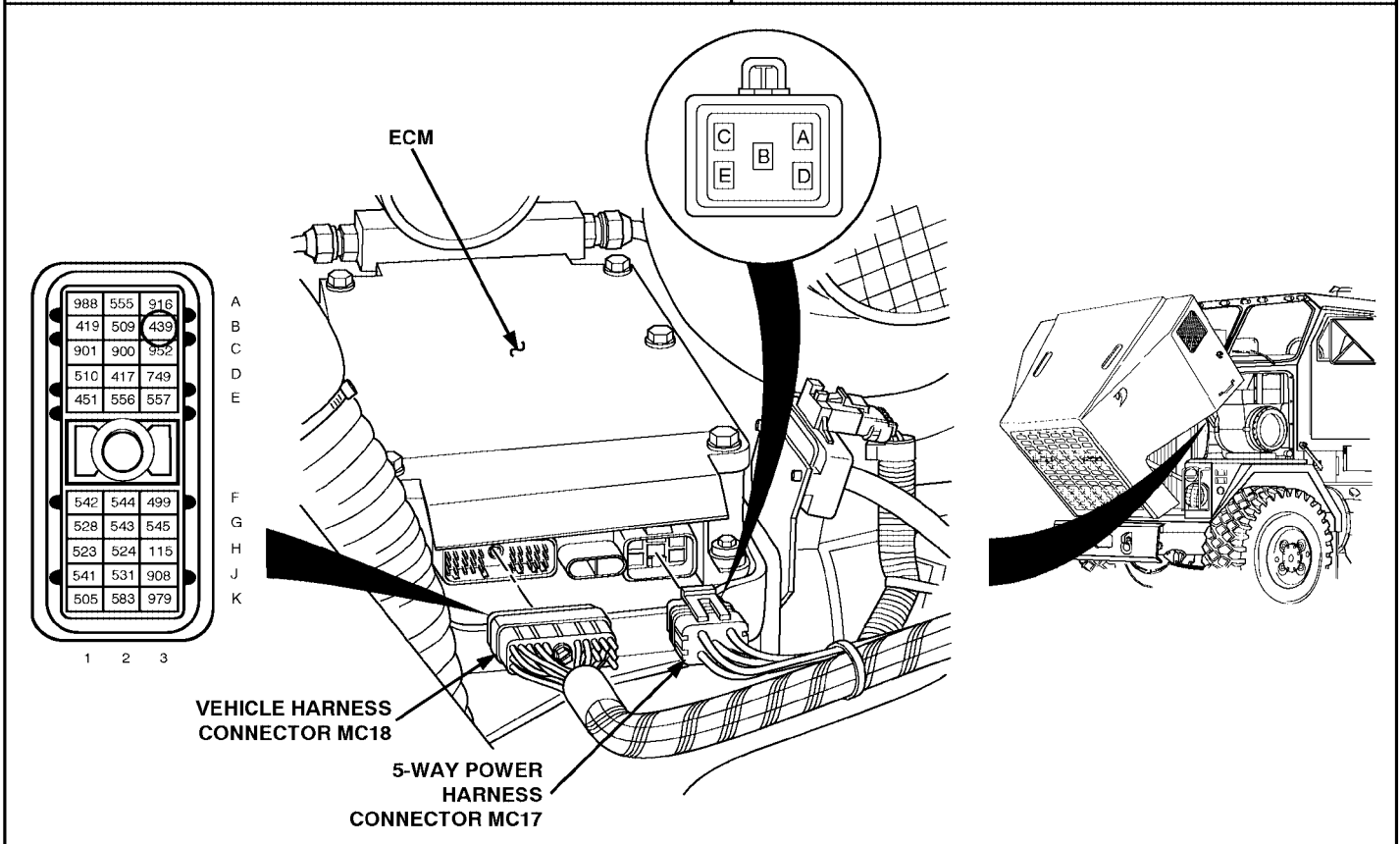
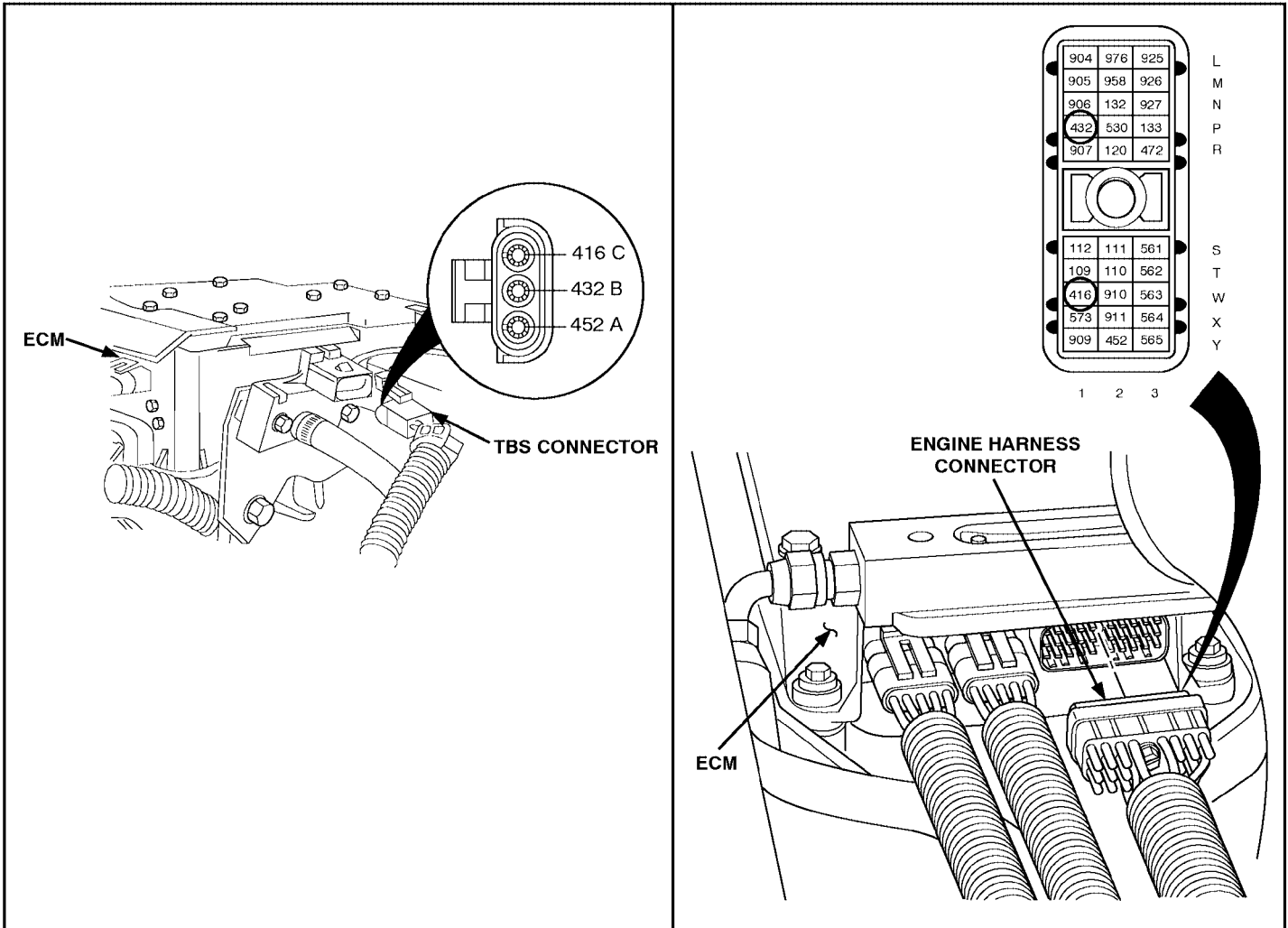

Section 4 TROUBLESHOOTING CHARTS

E. FLASH CODE: 33
J1587 CODE: P102 3 - TURBO BOOST PRESSURE CIRCUIT FAILED HIGH (HIGH VOLTAGE)

STEP/SEQUENCE	RESULT	WHAT TO DO NEXT
<p>33-5 Check for Short to +5 Volt Line</p> <ul style="list-style-type: none"> • Turn ignition off. • Disconnect engine harness connector at the ECM. • Read resistance between sockets W1 and P1 on the engine harness connector. 	<p>Less than or equal to 10,000 ohms.</p> <p>Greater than 10,000 ohms or open.</p>	<p>Signal line (ckt #432) is shorted to the engine +5 volt line (ckt #416). Repair short. Then go to 33-30.</p> <p>Go to 33-6.</p>
<p>33-6 Check for Short to Battery +</p> <ul style="list-style-type: none"> • Disconnect batteries (para 7-61). • Disconnect the vehicle harness and 5-way power harness connectors at the ECM. • Read resistance between socket P1 of the engine harness connector and socket B3 of the vehicle harness connector. • Also read resistance between socket P1 on the engine harness connector and the following sockets on the 5-way power harness connector: A and C. 	<p>All readings are greater than 10,000 ohms or open.</p> <p>Any reading is less than or equal to 10,000 ohms.</p>	<p>Go to 33-7.</p> <p>A short exists between the sockets where less than 10,000 ohms resistance was read. Repair short and connect batteries. Then go to 33-30.</p>
<p>33-7 Check ECM Connectors</p> <ul style="list-style-type: none"> • Check terminals at the engine harness connector (both the ECM and harness side) for damage; bent, corroded, and unseated pins or sockets. 	<p>Terminals and connectors are okay.</p> <p>Problem found.</p>	<p>Replace ECM (para 7-29.1). Then go to 33-30.</p> <p>Repair terminals/connectors (para 7-77). Then go to 33-30.</p>

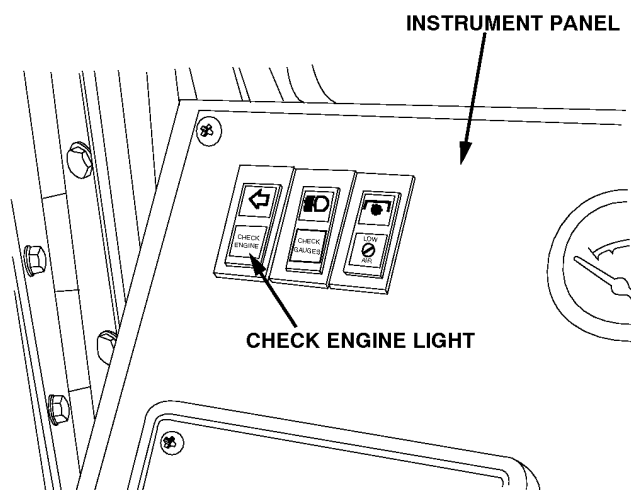

Section 4 TROUBLESHOOTING CHARTS

E. FLASH CODE: 33
 J1587 CODE: P102 3 - TURBO BOOST PRESSURE CIRCUIT FAILED HIGH (HIGH VOLTAGE)

STEP/SEQUENCE	RESULT	WHAT TO DO NEXT
<p>33-30 Verify Repairs</p>		
<ul style="list-style-type: none"> • Turn ignition off. • Reconnect all connectors. • Turn ignition on. • Clear codes. • Note status of "Check Engine" light. • If "Check Engine" light does not stay on, start engine and run (TM 9-2320-360-10 until "Check Engine" light comes on or 1 minute. Stop engine. • Read inactive codes. 	<p>No codes. →</p> <p>Code 102/3 (and any other codes). →</p> <p>Any other codes except Code 102/3. →</p>	<p>Repairs are complete.</p> <p>All system diagnostics are complete. Please review this section from the start to find the error.</p> <p>Go to START-10, pg H-25, to service other codes.</p>

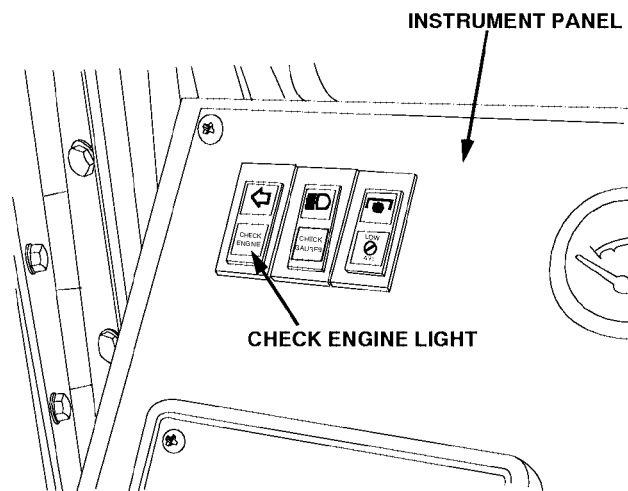
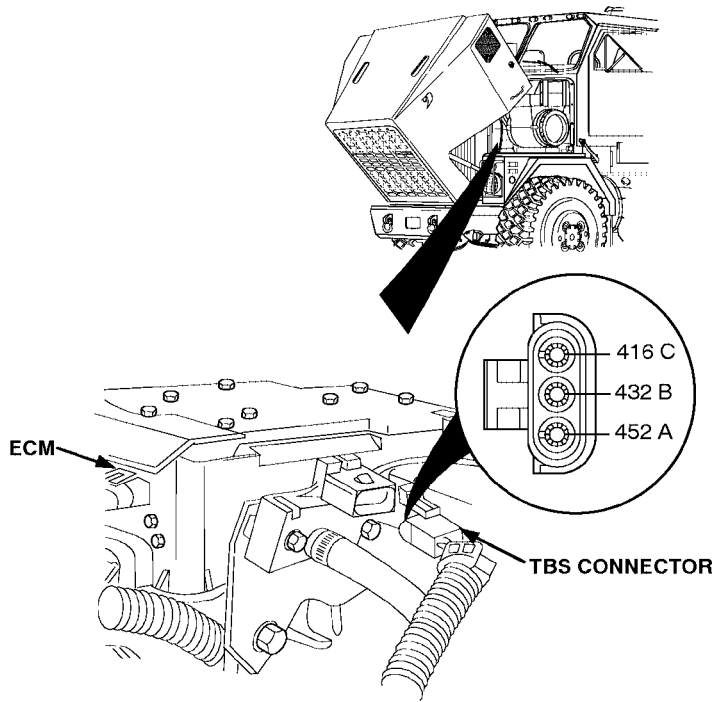

Section 4 TROUBLESHOOTING CHARTS

E. FLASH CODE: 34
J1587 CODE: P102 4 - TURBO BOOST PRESSURE CIRCUIT FAILED LOW (LOW VOLTAGE)

NOTE - This chart is only to be used if:

- 1) All basic mechanical checks and physical inspections have been performed with no problem found, and
- 2) Diagnosis of DDEC-III/IV was started at step START-1, pg H-25 and you have now been referred here.

STEP/SEQUENCE	RESULT	WHAT TO DO NEXT
<p>34-1 Multiple Code Check</p> <ul style="list-style-type: none"> • Were there any other active codes besides Code 102/4? 	<p>No other codes. →</p> <p>Yes, any or all of the following codes: 110/3 or 4, 175/3 or 4, 174/3 or 4, 102/3, 100/3 or 4, 187/4, 91/4. →</p> <p>Yes - but none of the above. →</p>	<p>Go to 34-2.</p> <p>Go to ENG5V-1 (page H-241).</p> <p>Go to 34-2.</p>
<p>34-2 Sensor Check</p> <ul style="list-style-type: none"> • Turn ignition off. • Disconnect TBS connector. • Install a jumper wire between sockets B and C of the TBS connector. • Turn ignition on. • Read active codes. • If active Code 102/3 or 4 exists go to RESULT column. • If no active Code 102/3 or 4 exists, start engine and run (TM 9-2320-360-10) until either the "Check Engine" light comes on or the engine has been running warm for at least one minute at greater than 1000 RPM. • Read active codes. 	<p>Code 102/3 (and any codes except except Code 102/4). →</p> <p>Code 102/4 (and any other codes). →</p>	<p>Go to 34-3.</p> <p>Go to 34-4.</p>
<p>34-3 Check TBS Connectors</p> <ul style="list-style-type: none"> • Inspect terminals at the TBS connectors (both the sensor and harness side) for damage; bent, corroded, and unseated pins or sockets. 	<p>Terminals and connectors are okay. →</p> <p>Problem found. →</p>	<p>Replace TBS (para 7-36). Then go to 34-30.</p> <p>Repair terminals/connectors (para 7-77). Then go to 34-30.</p>

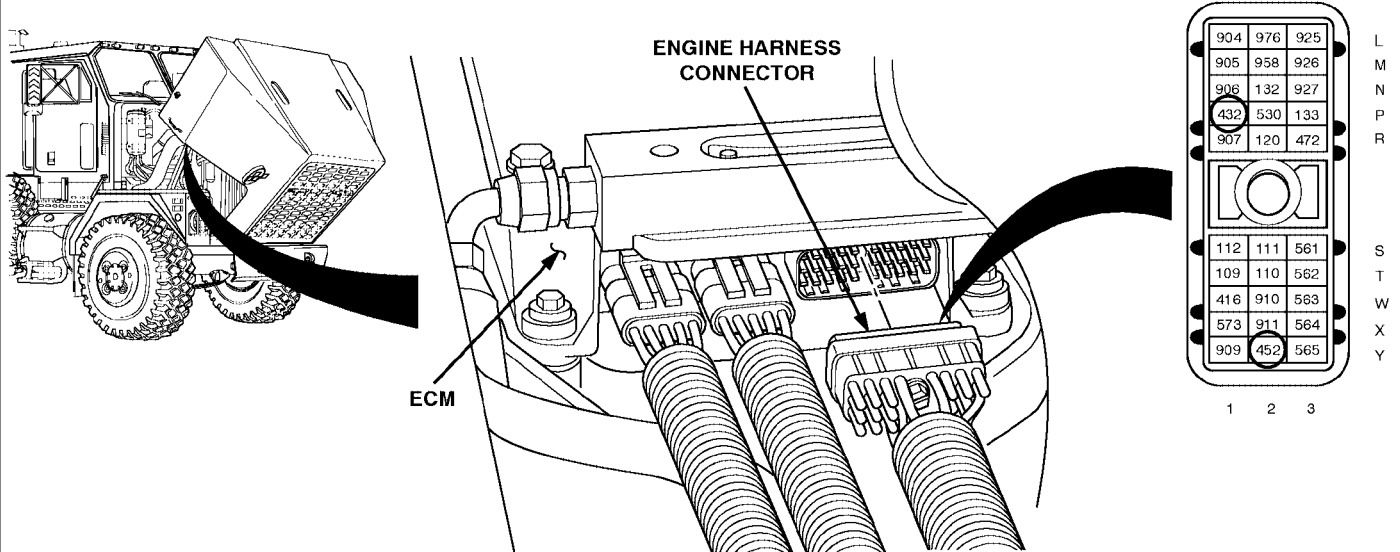
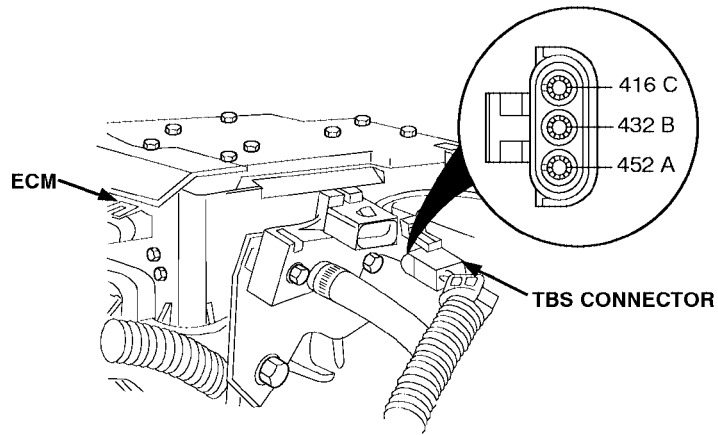

Section 4 TROUBLESHOOTING CHARTS

E. FLASH CODE: 34
J1587 CODE: P102 4 - TURBO BOOST PRESSURE CIRCUIT FAILED LOW (LOW VOLTAGE)

STEP/SEQUENCE	RESULT	WHAT TO DO NEXT
<p>34-4 Check for +5 Volts</p> <ul style="list-style-type: none"> • Remove jumper wire. • Turn ignition on. • Read voltage on TBS connector, pin C (red lead) to pin A (black lead). 	<p>Between 4 to 6 volts. →</p> <p>Less than 4 volts. →</p> <p>Greater than 6 volts. →</p>	<p>Go to 34-5.</p> <p>Go to 34-8.</p> <p>Go to 34-10.</p>
<p>34-5 Check for Signal Open</p> <ul style="list-style-type: none"> • Turn ignition off. • Disconnect the engine harness connector at the ECM. • Install a jumper wire between pins A and B of the TBS connector. • Read resistance between sockets P1 and Y2 on the engine harness connector. 	<p>Less than or equal to 5 ohms. →</p> <p>Greater than 5 ohms or open. →</p>	<p>Go to 34-6.</p> <p>Signal line (ckt #432) or return line (ckt #452) is open. Repeat check from pin A to Y2 and pin B to P1. Repair open. Then go to 34-30.</p>
<p>34-6 Check for Short</p> <ul style="list-style-type: none"> • Remove jumper. • Read resistance between pins A and B on the TBS connector. • Also read resistance between socket B and a good ground. 	<p>Less than or equal to 10,000 ohms on either readings. →</p> <p>Greater than 10,000 ohms or open on both readings. →</p>	<p>Signal line (ckt #432) is shorted to the return line (ckt #452). Repair short. Then go to 34-30.</p> <p>Then go to 34-7.</p>
<p>34-7 Check ECM Connectors</p> <ul style="list-style-type: none"> • Check terminals at the engine harness connector (both the ECM and harness side) for damage; bent, corroded, and unseated pins or sockets. 	<p>Terminals and connectors are okay. →</p> <p>Problem found. →</p>	<p>Replace ECM (para 7-29.1). Then go to 34-30.</p> <p>Repair terminals/connectors (para 7-77). Then go to 34-30.</p>

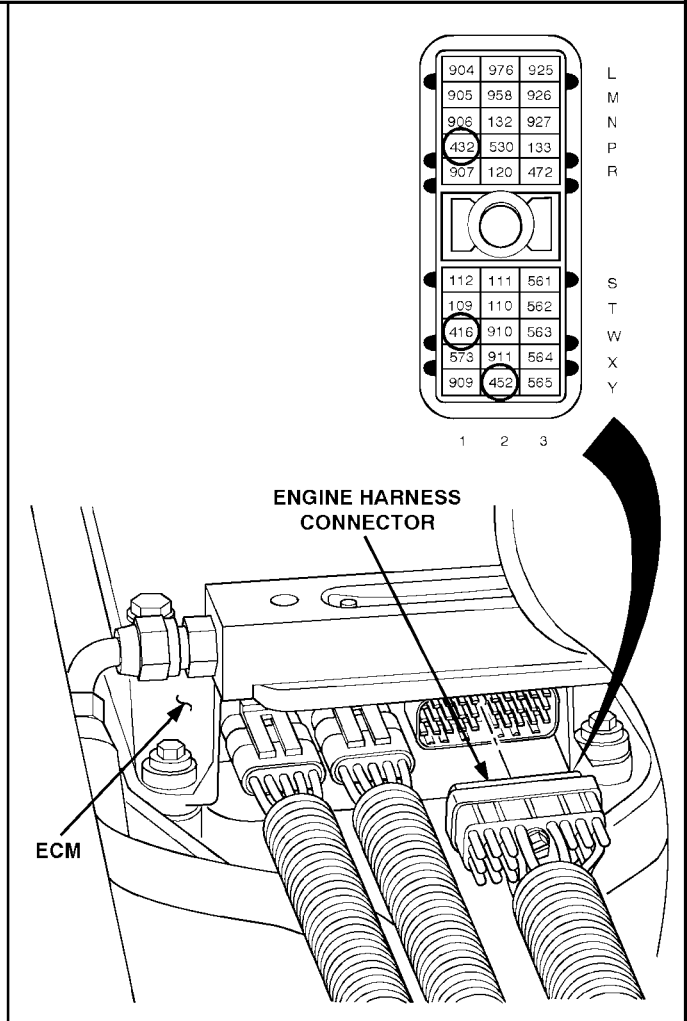
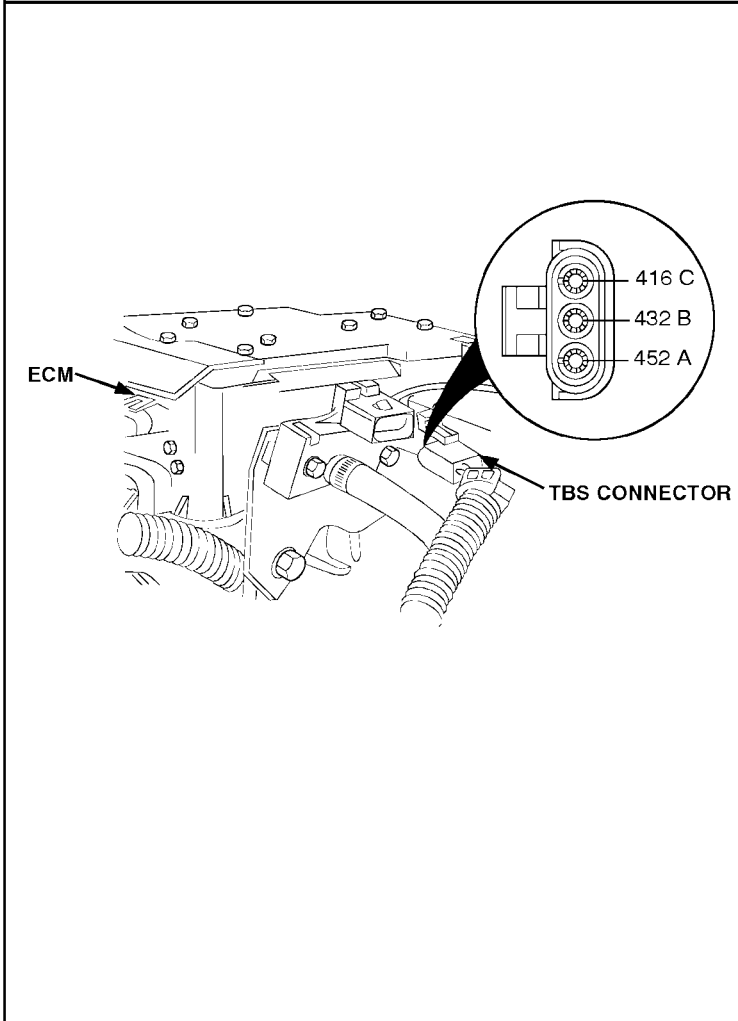
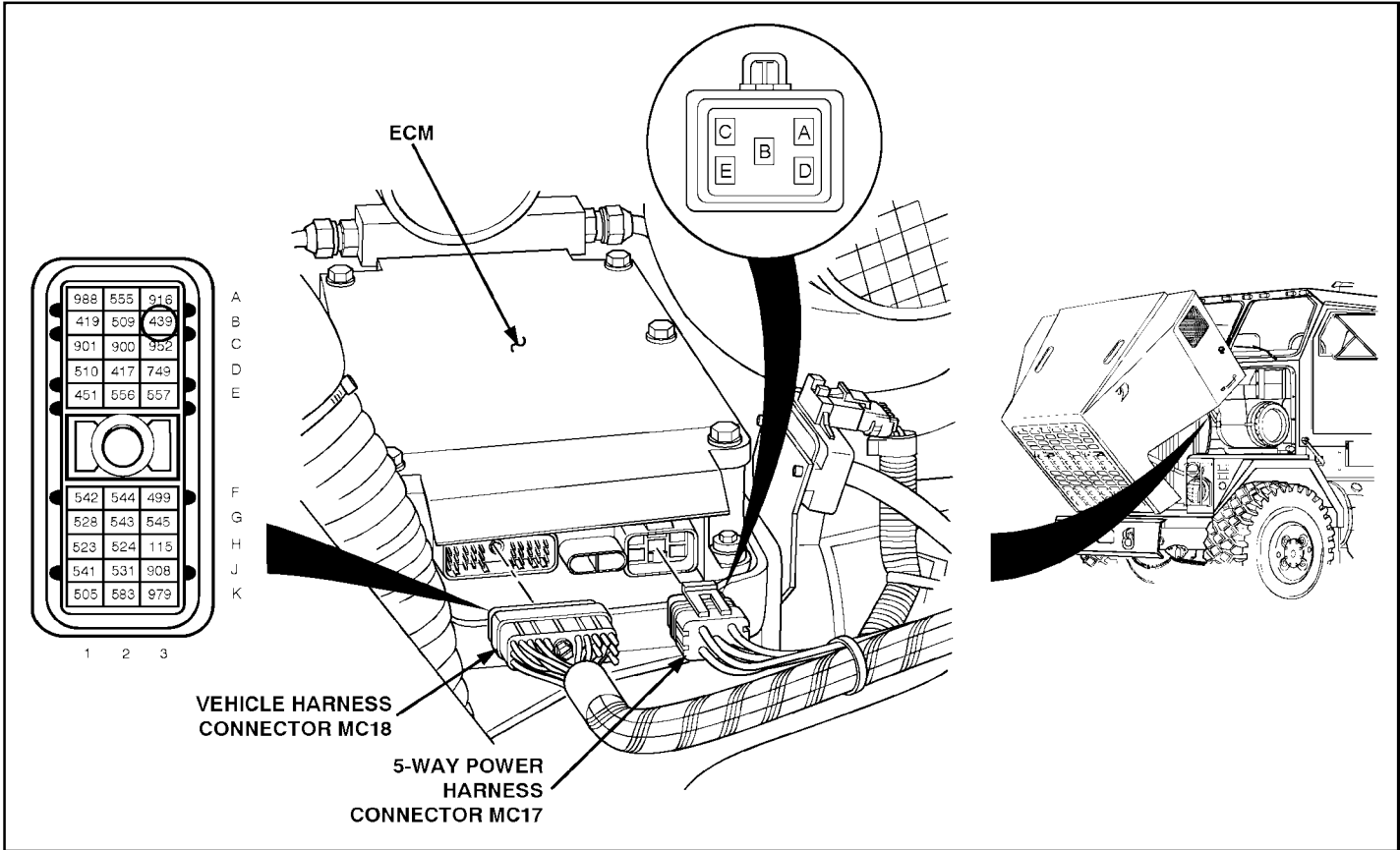

Section 4 TROUBLESHOOTING CHARTS

E. FLASH CODE: 34
J1587 CODE: P102 4 - TURBO BOOST PRESSURE CIRCUIT FAILED LOW (LOW VOLTAGE)

STEP/SEQUENCE	RESULT	WHAT TO DO NEXT
<p>34-8 Check for Open +5 Volt Line</p> <ul style="list-style-type: none"> • Turn ignition off. • Disconnect the vehicle harness connectors at the ECM. • Install a jumper wire between pins A and C of the TBS connector. • Read resistance between sockets W1 and Y2 on the engine harness connector. 	<p>Less than or equal to 5 ohms. →</p> <p>Greater than 5 ohms or open. →</p>	<p>Go to 34-9.</p> <p>The engine +5 volt line (ckt #416) is open. Repair open. Then go to 34-30.</p>
<p>34-9 Check for Short</p> <ul style="list-style-type: none"> • Remove jumper. • Read resistance between pins A and C on the TBS connector. 	<p>Less than or equal to 10,000 ohms. →</p> <p>Greater than 10,000 ohms or open. →</p>	<p>The +5 volt line (ckt #416) is shorted to return line (ckt #452). Repair short. Then go to 34-30.</p> <p>Go to 34-7.</p>
<p>34-10 Check for Short to Battery +</p> <ul style="list-style-type: none"> • Turn ignition off. • Disconnect batteries (para 7-61). • Disconnect the engine harness vehicle harness and 5-way power harness connectors at the ECM. • Read resistance between socket P1 of the engine harness connector and socket B3 of the vehicle harness connector. • Also read resistance between socket P1 on the engine harness connector and the following sockets on the 5-way power harness connector: A and C. 	<p>All readings are greater than 10,000 ohms or open. →</p> <p>Any reading is less than or equal to 10,000 ohms. →</p>	<p>Go to 34-7.</p> <p>A short exists between the sockets where less than 10,000 ohms resistance was read. Repair short and connect batteries. Then go to 34-30.</p>

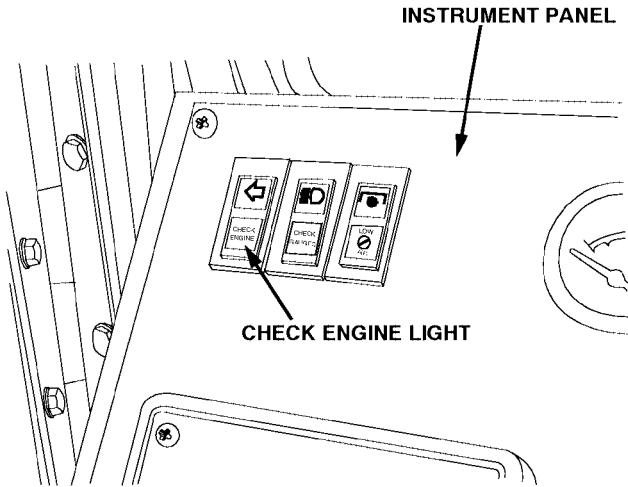

Section 4 TROUBLESHOOTING CHARTS

E. FLASH CODE: 34
 J1587 CODE: P102 4 - TURBO BOOST PRESSURE CIRCUIT FAILED LOW (LOW VOLTAGE)

STEP/SEQUENCE	RESULT	WHAT TO DO NEXT
34-30 Verify Repairs		
<ul style="list-style-type: none"> • Turn ignition off. • Reconnect all connectors. • Turn ignition on. • Clear codes. • Note status of "Check Engine" light. • If "Check Engine" light does not stay on, start engine and run (TM 9-2320-360-10) until "Check Engine" light comes on or 1 minute. Stop engine. • Read inactive codes. 	<p>No codes. </p> <p>Code 102/4 (and any other codes). </p> <p>Any other codes except Code 102/4. </p>	<p>Repairs are complete.</p> <p>All system diagnostics are complete. Please review this section from the start to find the error.</p> <p>Go to START-1, pg H-25, to service other codes.</p>

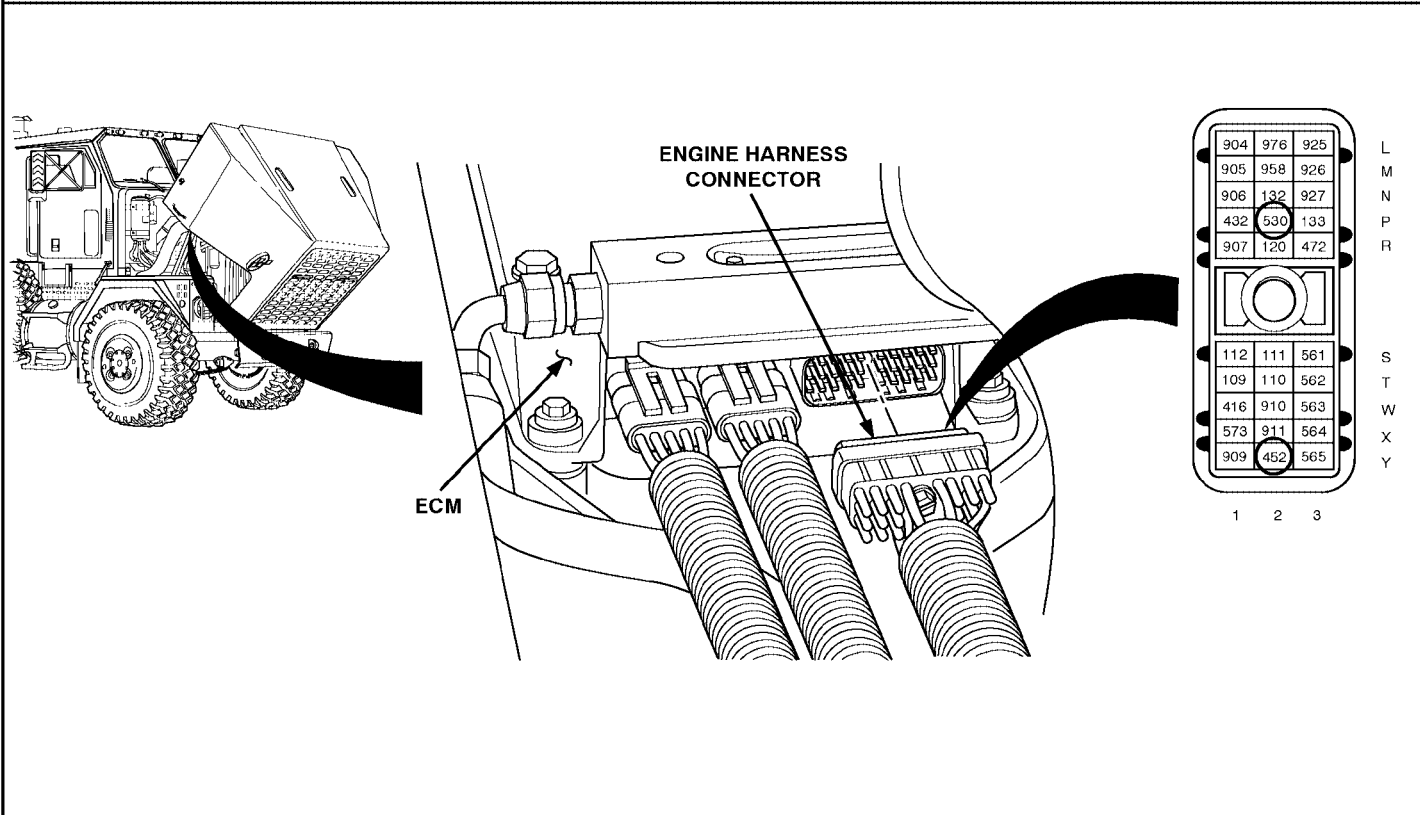
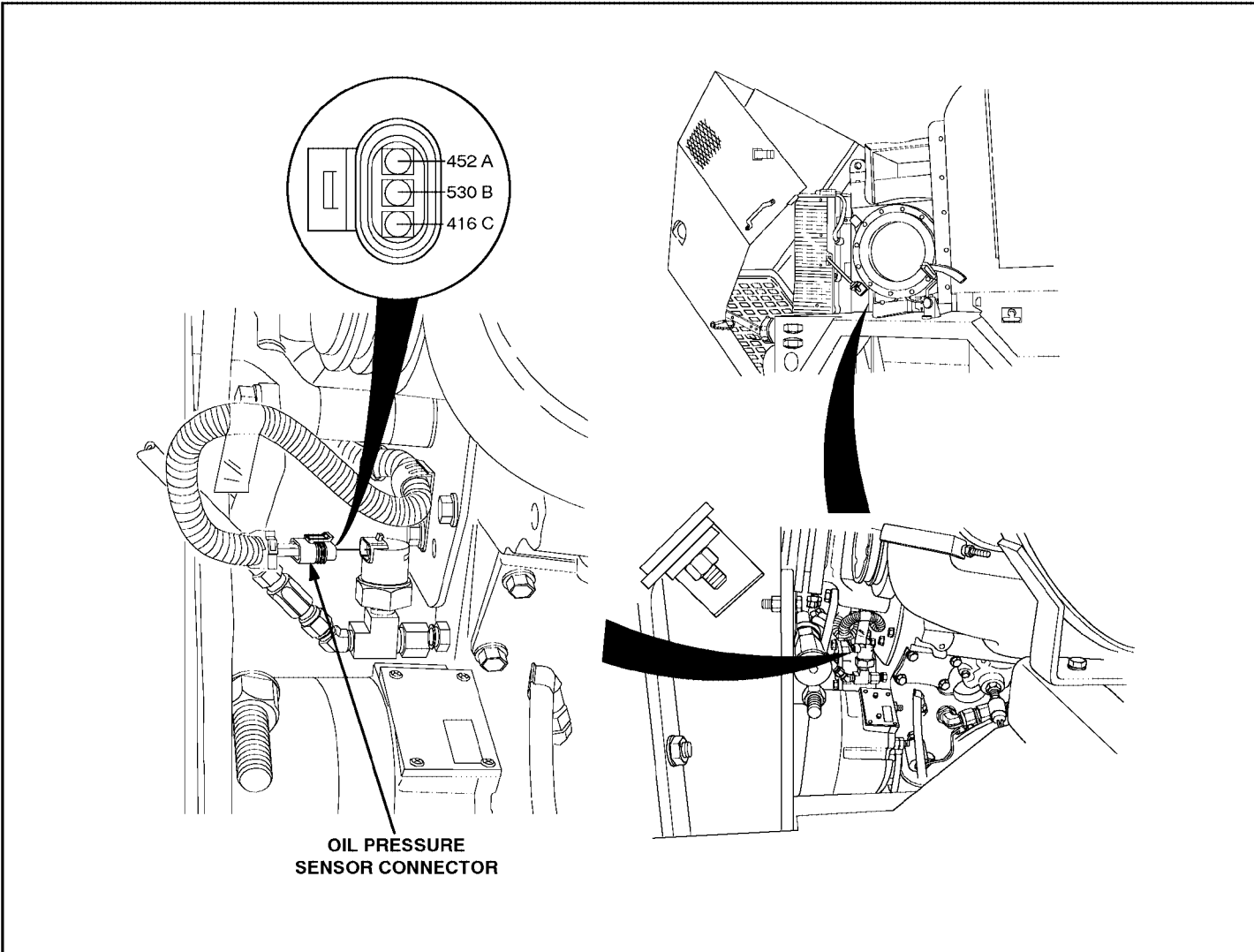

Section 4 TROUBLESHOOTING CHARTS

E. FLASH CODE: 35
J1587 CODE: P100 3 - OIL PRESSURE CIRCUIT FAILED HIGH (HIGH VOLTAGE)

NOTE - This chart is only to be used if:

- 1) All basic mechanical checks and physical inspections have been performed with no problem found, and
- 2) Diagnosis of DDEC-III/IV was started at step START-1, pg H-25 and you have now been referred here.

STEP/SEQUENCE	RESULT	WHAT TO DO NEXT
<p>35-1 Multiple Code Check</p> <ul style="list-style-type: none"> • Were there any other active codes besides Code 100/3? 	<p>No other codes. →</p> <p>Yes, any or all of the following codes: 110/3 or 4, 175/3 or 4, 174/3 or 4, 102/3 or 4, 100/4. →</p> <p>Yes - but none of the above. →</p>	<p>Go to 35-2.</p> <p>Go to ENG5V-1 (page H-241).</p> <p>Go to 35-2.</p>
<p>35-2 Sensor Check</p> <ul style="list-style-type: none"> • Turn ignition off. • Disconnect OPS connector. • Turn ignition on. • Start and run engine (TM 9-2320-360-10). • Select Engine Temperature (COOLANT TEMP or OIL TEMP) on the DDR. • Warm up engine until engine temperature reading is greater than 60 degrees C (140 degrees F). • Leave engine running at idle after warm up. • Read active codes. 	<p>Code 100/4 (and any codes except Code 100/3). →</p> <p>Code 100/3 (and any other codes). →</p>	<p>Go to 35-3.</p> <p>Go to 35-5.</p>
<p>35-3 Return Circuit Check</p> <ul style="list-style-type: none"> • Turn ignition off. • Disconnect engine harness connector at the ECM. • Install a jumper wire between pins A and B of the OPS connector. • Read resistance between sockets P2 and Y2 on the engine harness connector. 	<p>Less than or equal to 5 ohms. →</p> <p>Greater than 5 ohms or open. →</p>	<p>Go to 35-4.</p> <p>Return line (ckt #452) is open. Repair open. Then go to 35-30.</p>

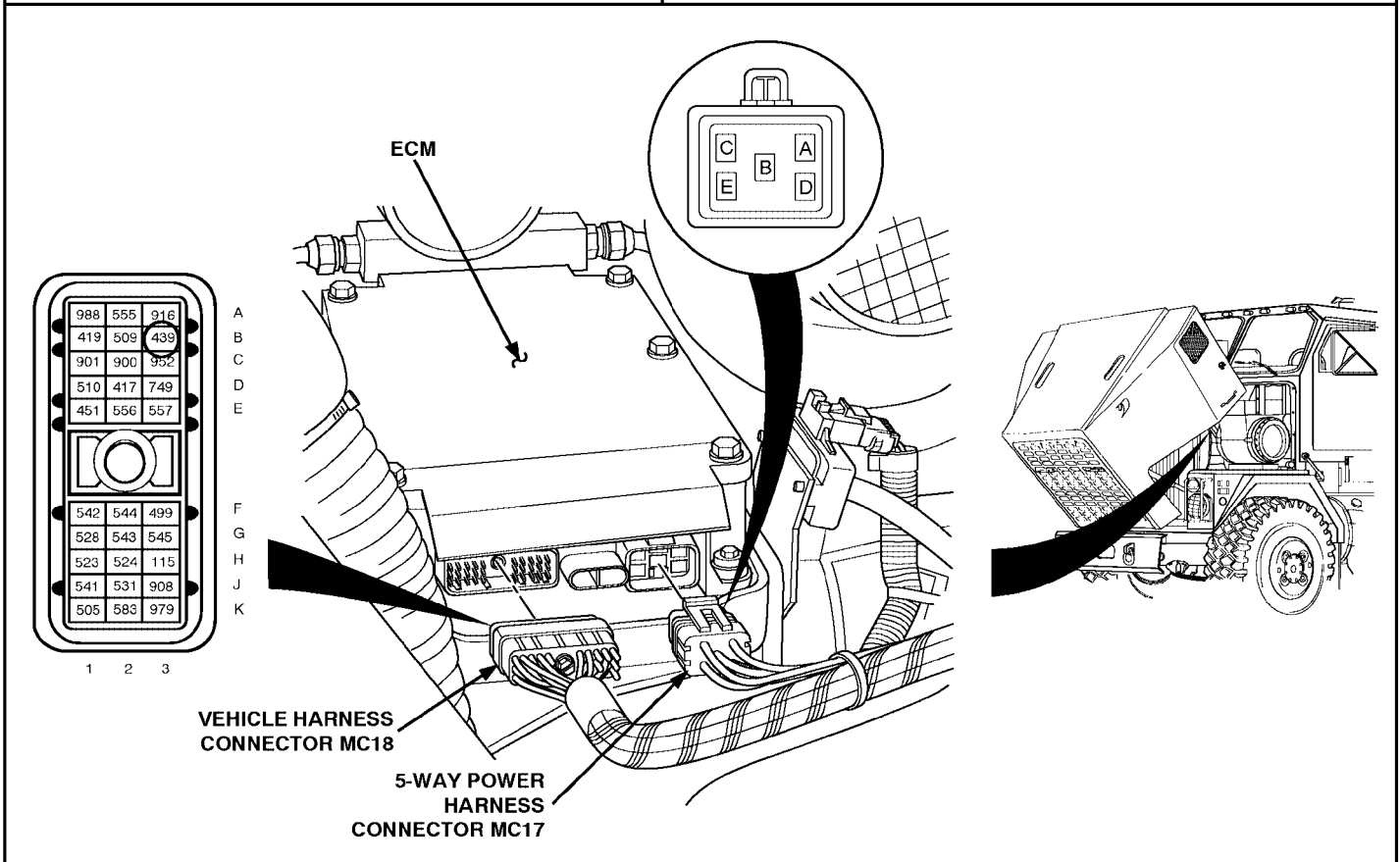
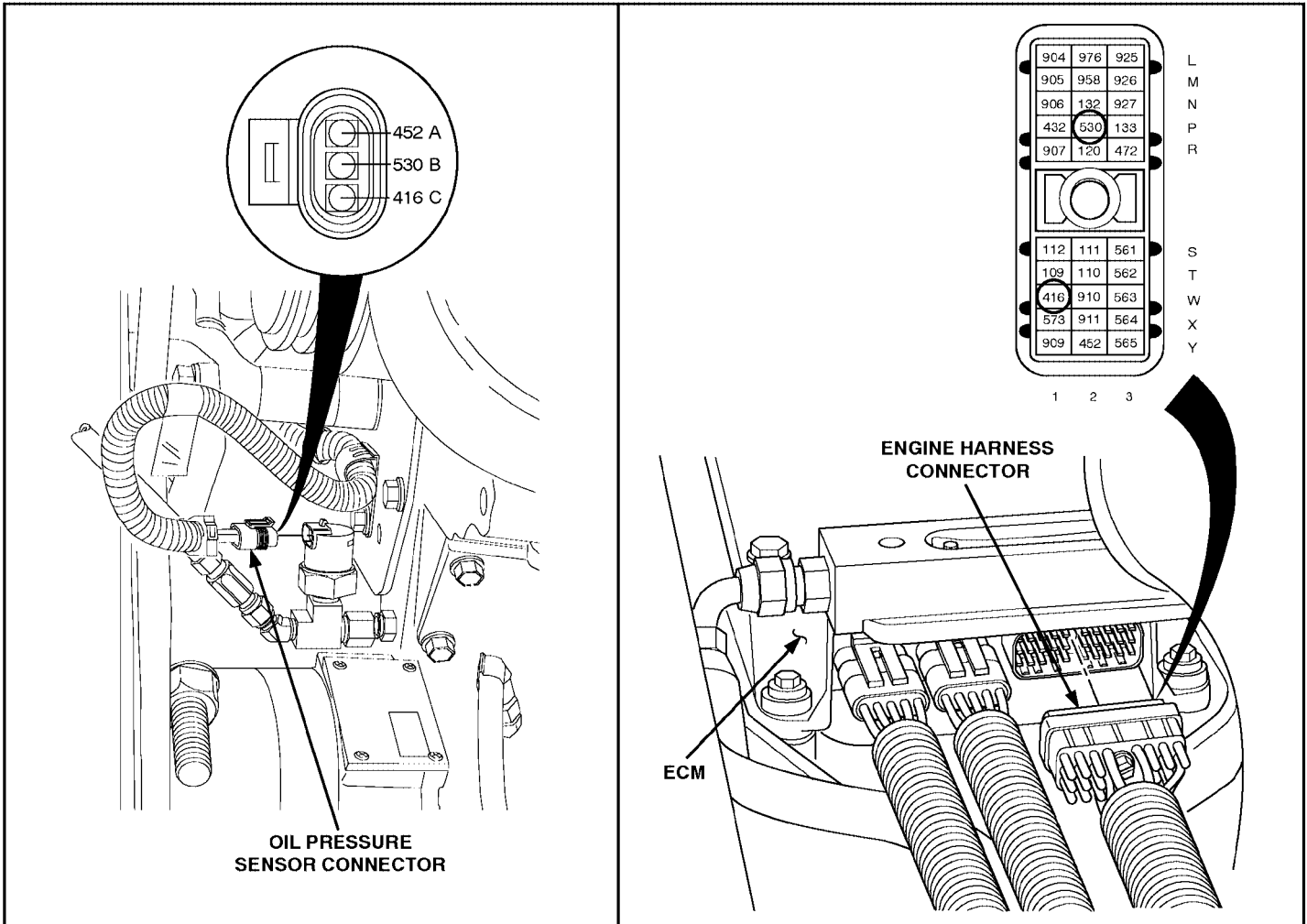

Section 4 TROUBLESHOOTING CHARTS

E. FLASH CODE: 35
J1587 CODE: P100 3 - OIL PRESSURE CIRCUIT FAILED HIGH (HIGH VOLTAGE)

STEP/SEQUENCE	RESULT	WHAT TO DO NEXT
<p>35-4 Check OPS Connectors</p> <ul style="list-style-type: none"> • Inspect terminals at the OPS connectors (both the sensor and harness side) for damage; bent, corroded, and unseated pins or sockets. 	<p>Terminals and connectors are okay. →</p> <p>Problem found. →</p>	<p>Replace OPS (para 7-35.1). Then go to 35-30.</p> <p>Repair terminals/connectors (para 7-77). Then go to 35-30.</p>
<p>35-5 Check for Short</p> <ul style="list-style-type: none"> • Turn ignition off. • Disconnect the engine harness connector at the ECM. • Read resistance between sockets W1 and P2 on the engine harness connector. 	<p>Less than or equal to 10,000 ohms. →</p> <p>Greater than 10,000 ohms or open. →</p>	<p>Signal line (ckt #530) is shorted to the engine +5 volt line (ckt #416). Repair short. Then go to 35-30.</p> <p>Go to 35-6.</p>
<p>35-6 Check for Short to Battery +</p> <ul style="list-style-type: none"> • Disconnect batteries (para 7-61). • Disconnect the vehicle harness and 5-way power harness connectors at the ECM. • Read resistance between socket P2 of the engine harness connector and socket B3 of the vehicle harness connector. • Also read resistance between socket P2 on the engine harness connector and the following sockets on the 5-way power harness connector: A and C. 	<p>All readings are greater than 10,000 ohms or open. →</p> <p>Any reading is less than or equal to 10,000 ohms. →</p>	<p>Go to 35-8.</p> <p>A short exists between the sockets where less than 10,000 ohms resistance was read. Repair short and connect batteries. Then go to 35-30.</p>

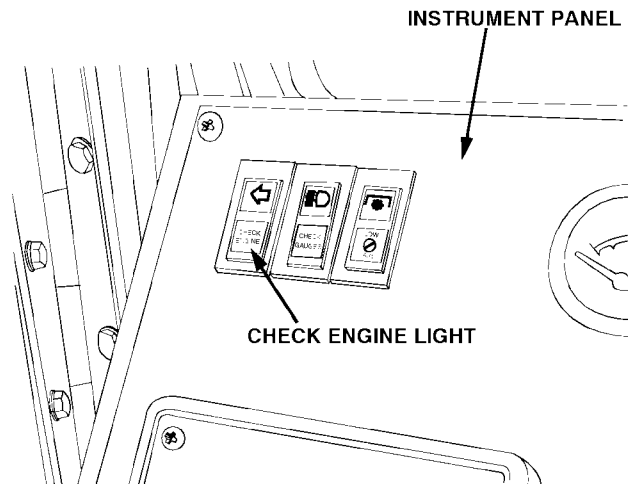
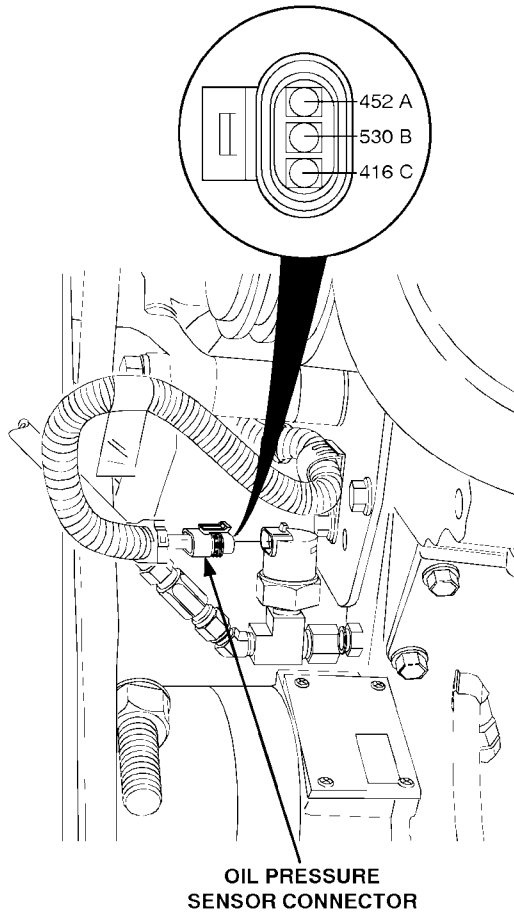

Section 4 TROUBLESHOOTING CHARTS

E. FLASH CODE: 35
 J1587 CODE: P100 3 - OIL PRESSURE CIRCUIT FAILED HIGH (HIGH VOLTAGE)

STEP/SEQUENCE	RESULT	WHAT TO DO NEXT
<p>35-7 Final Check</p> <ul style="list-style-type: none"> • Reconnect all connectors. • Turn ignition on. • Clear codes. • Start engine (TM 9-2320-360-10). Run for one minute or until "Check Engine" light comes on. • Stop engine. • Check active codes. 	<p>Code 100/3. →</p> <p>No codes. →</p> <p>Any other codes except Code 100/3. →</p>	<p>Replace ECM (para 7-29.1). Then go to 35-30.</p> <p>Repairs are complete.</p> <p>Go to START-1, pg H-25, to service other codes.</p>
<p>35-8 Check OPS Connectors</p> <ul style="list-style-type: none"> • Inspect terminals at OPS connectors (sensor and harness sides) for damage; bent, corroded and unseated pins or sockets. 	<p>Terminals and connectors are okay. →</p> <p>Problem found. →</p>	<p>Replace OPS (para 7-35.1). Then go to 35-7.</p> <p>Repair terminals/connectors (para 7-77). Then go to 35-30.</p>
<p>35-30 Verify Repairs</p> <ul style="list-style-type: none"> • Turn ignition off. • Reconnect all connectors. • Turn ignition on. • Clear codes. • Note status of "Check Engine" light. • If "Check Engine" light does not stay on, start engine and run (TM 9-2320-360-10) until "Check Engine" light comes on or engine has run warm (greater than 60 degrees C, 140 degrees F) 1 minute. • Read inactive codes. 	<p>No codes. →</p> <p>Code 100/3 (and any other codes). →</p> <p>Any other codes except Code 100/3 →</p>	<p>Repairs are complete.</p> <p>All system diagnostics are complete. Please review this section from the start to find the error.</p> <p>Go to START-1, pg H-25, to service other codes.</p>

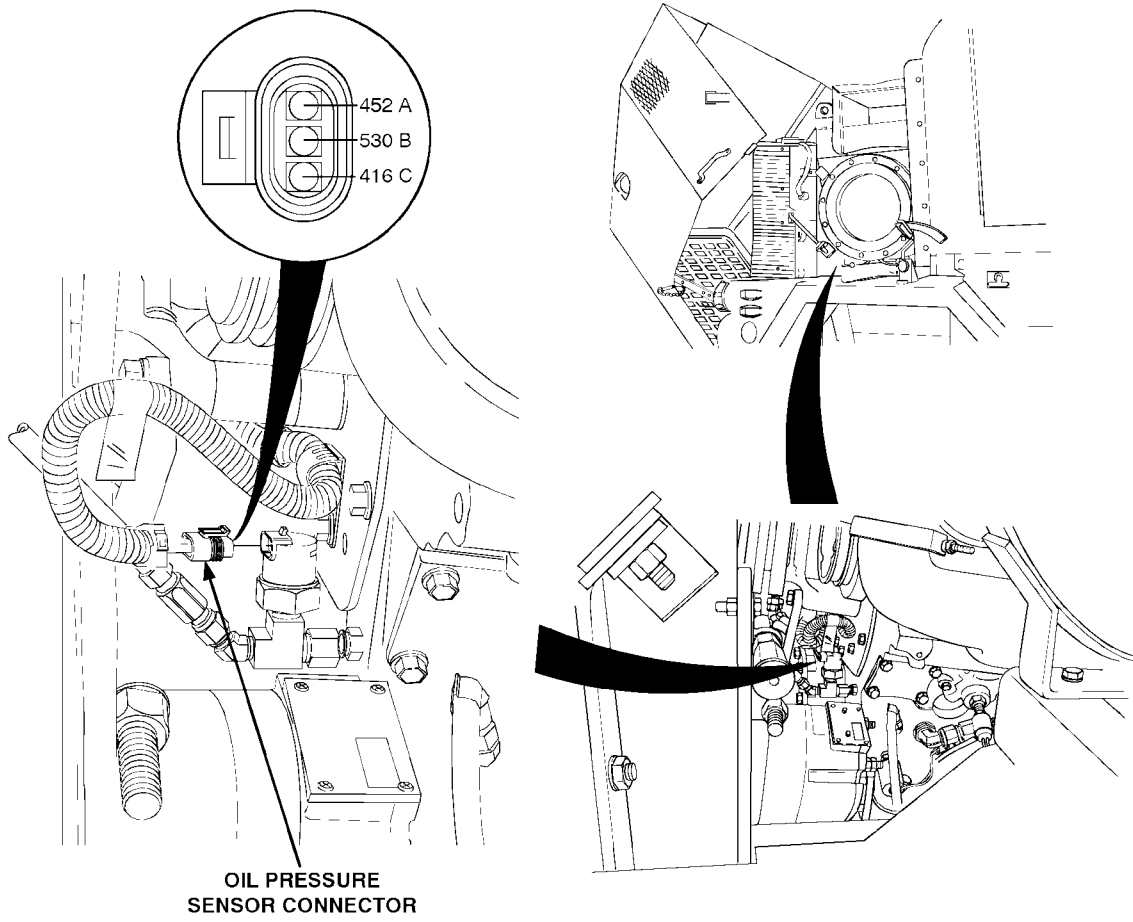

Section 4 TROUBLESHOOTING CHARTS

E. FLASH CODE: 36
J1587 CODE: P100 4 - OIL PRESSURE CIRCUIT FAILED LOW (LOW VOLTAGE)

NOTE - This chart is only to be used if:

- 1) All basic mechanical checks and physical inspections have been performed with no problem found, and
- 2) Diagnosis of DDEC-III/IV was started at step START-1, pg H-25 and you have now been referred here.

STEP/SEQUENCE	RESULT	WHAT TO DO NEXT
<p>36-1 Multiple Code Check</p> <ul style="list-style-type: none"> • Were there any other active codes besides Code 100/4? 	<p>No other codes. →</p> <p>Yes, any or all of the following codes: 110/3 or 4, 175/3 or 4, 174/3 or 4, 102/3 or 4, 100/3, 187/4, 91/4. →</p> <p>Yes - but none of the above. →</p>	<p>Go to 36-2.</p> <p>Go to ENG5V-1 (page H-241).</p> <p>Go to 36-2.</p>
<p>36-2 Sensor Check</p> <ul style="list-style-type: none"> • Turn ignition off. • Disconnect OPS connector and install a jumper wire between sockets B and C of the OPS connector. • Turn ignition on. • Read active codes. • If active Code 100/3 or 4 exists, go to RESULT column. • If no active Code 100/3 or 4 exists, start and run (TM 9-2320-360-10) engine until either active Code 100/3 or 4 appears or the engine temperature COOLANT TEMP or OIL TEMP or DDR has been greater than 60 degrees C (140 deg F) for more than 1 minute. 	<p>Code 100/3 (and any codes except Code 100/4). →</p> <p>Code 100/4 (and any other codes). →</p> <p>No codes. →</p>	<p>Check to be sure ECM and OPS connectors are wired properly. If wired properly then go to 36-3.</p> <p>Go to 36-4.</p> <p>Go to 36-4.</p>
<p>36-3 Check OPS Connectors</p> <ul style="list-style-type: none"> • Turn ignition off. • Inspect terminals at the OPS connectors (sensor side and harness side) for damage; bent, corroded, and unseated pins or sockets. 	<p>Terminals and connectors are okay. →</p> <p>Problem found. →</p>	<p>Replace OPS (para 7-35.1). Then go to 36-30.</p> <p>Repair terminals/connectors (para 7-77). Then go to 36-30.</p>

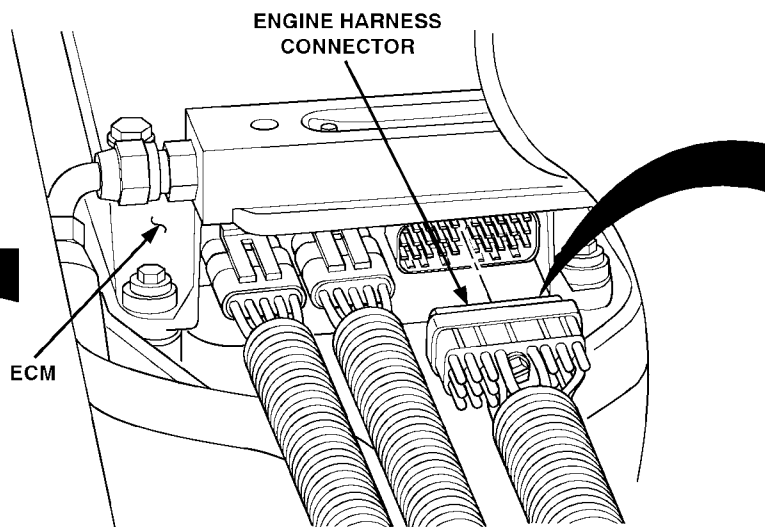
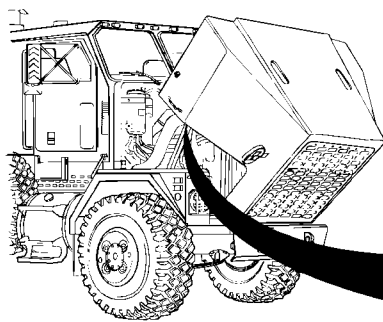
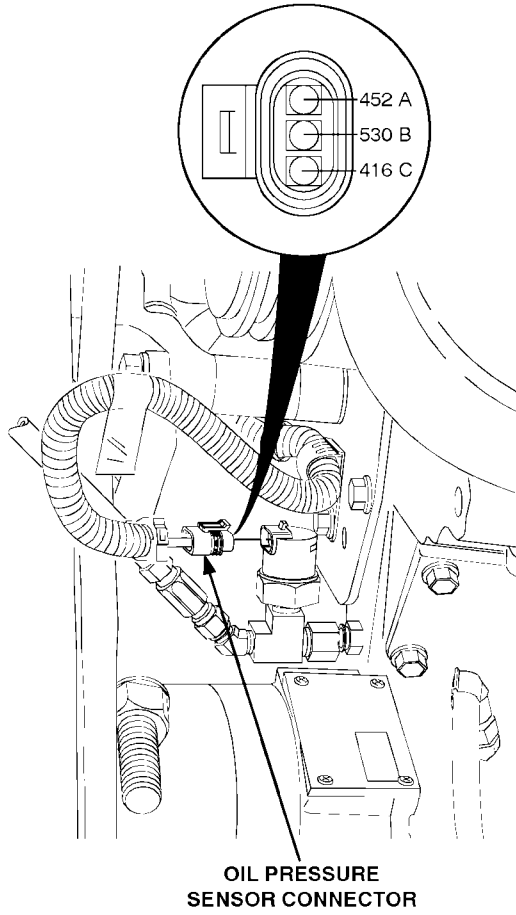

904	976	925
905	958	926
906	132	927
432	530	133
907	120	472
112	111	561
109	110	562
416	910	563
873	911	564
909	452	565

1 2 3

L
M
N
P
R

S
T
W
X
Y

Section 4 TROUBLESHOOTING CHARTS

E. FLASH CODE: 36
J1587 CODE: P100 4 - OIL PRESSURE CIRCUIT FAILED LOW (LOW VOLTAGE)

STEP/SEQUENCE	RESULT	WHAT TO DO NEXT
<p>36-4 Check for +5 Volts</p> <ul style="list-style-type: none"> • Turn ignition off. • Remove jumper wire. • Turn ignition on. • Read voltage on OPS connector, socket C (red lead) to socket A (black lead). 	<p>Between 4 to 6 volts. → Go to 36-5.</p> <p>Less than 4 volts. → Go to 36-8.</p> <p>Greater than 6 volts. → Go to 36-10.</p>	
<p>36-5 Check for Signal Open</p> <ul style="list-style-type: none"> • Turn ignition off. • Disconnect the engine harness connector at the ECM. • Install a jumper wire between sockets A and B of the OPS connector. • Read resistance between sockets P2 and Y2 on the engine harness connectors. 	<p>Less than or equal to 5 ohms on either reading. → Go to 36-11.</p> <p>Greater than 5 ohms or open. → Signal line (ckt #530) is open. Repair open. Then go to 36-30.</p>	
<p>36-6 Check for Short</p> <ul style="list-style-type: none"> • Remove jumper wire. • Disconnect the engine harness connector at the ECM. • Read resistance between sockets A and B on the OPS connector. • Also read resistance between socket B and a good ground. 	<p>Less than or equal to 10,000 ohms. → Signal line (ckt #530) is shorted to the return line (ckt #452) or battery ground. Repair short. Then go to 36-30.</p> <p>Greater than 10,000 ohms or open. on both readings. → Go to 36-12.</p>	
<p>36-7 Check ECM Connectors</p> <ul style="list-style-type: none"> • Check terminals at the engine harness connector (both the ECM and harness side) for damage; bent, corroded and unseated pins or sockets. Especially W1, P2, and Y2 terminals and pins at ECM. 	<p>Terminals and connectors are okay. → Replace ECM (para 7-29.1). Then go to 36-30.</p> <p>Problem found. → Repair terminals/connectors (para 7-77). Then go to 36-30.</p>	

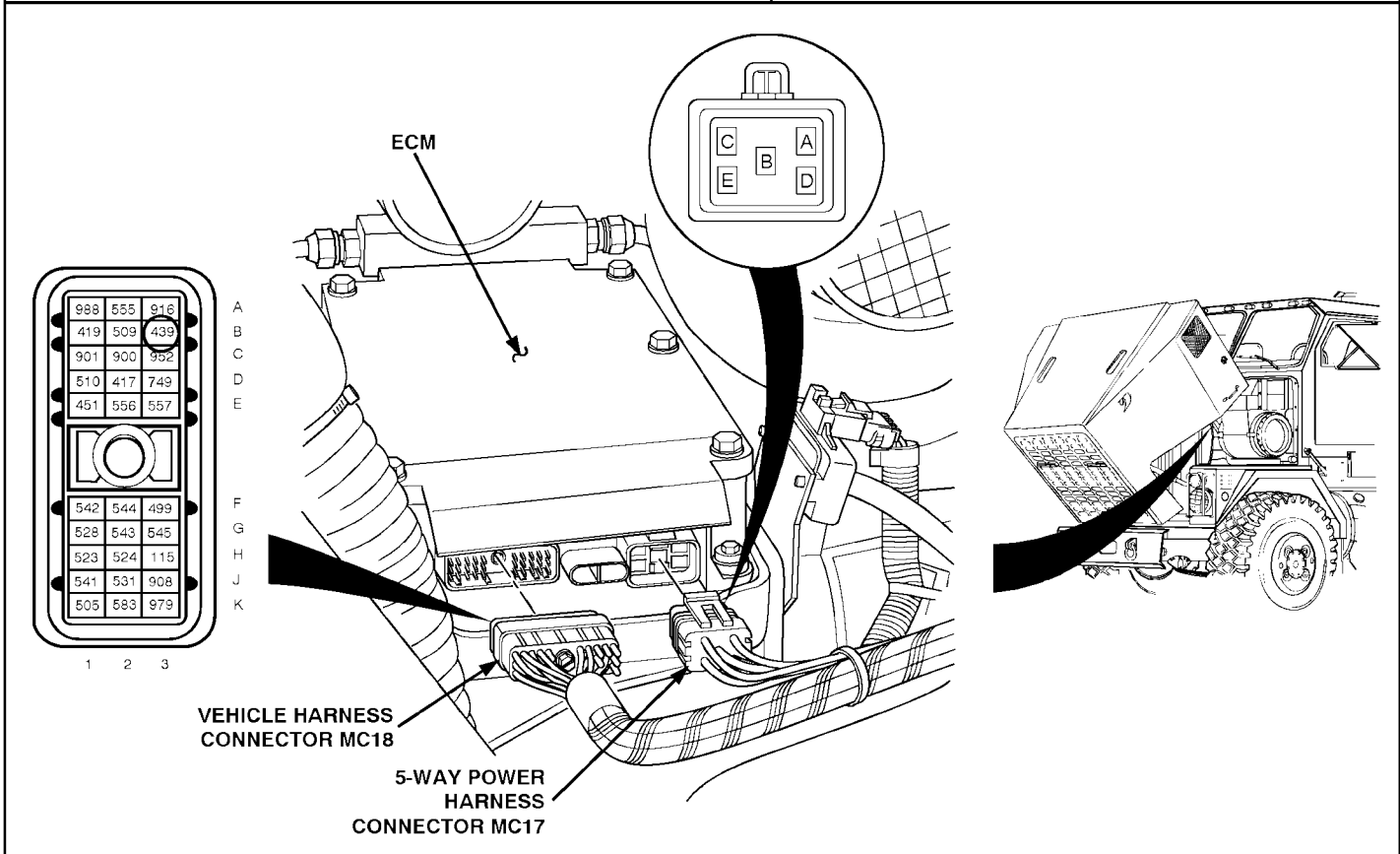
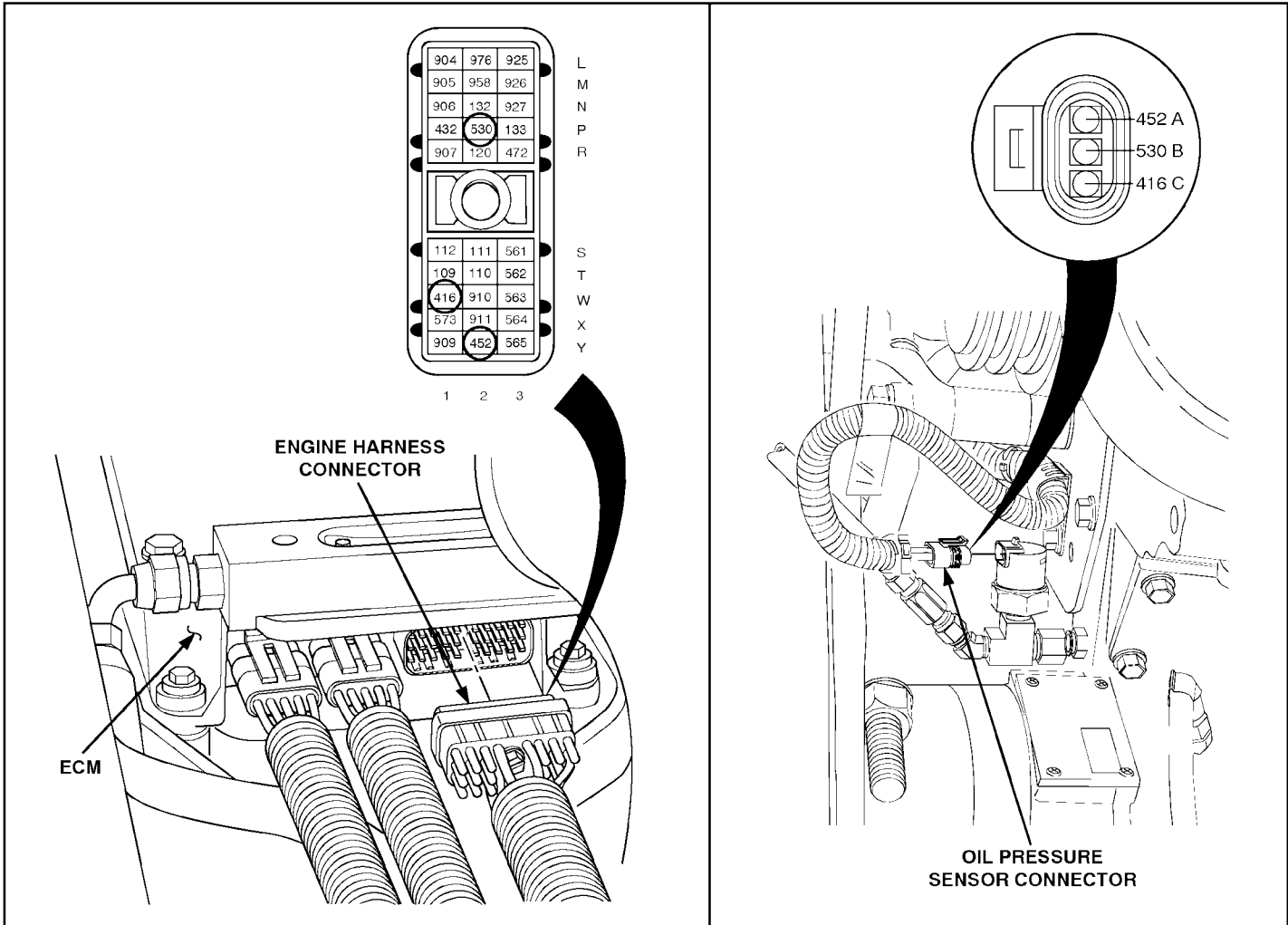

Section 4 TROUBLESHOOTING CHARTS

E. FLASH CODE: 36
J1587 CODE: P100 4 - OIL PRESSURE CIRCUIT FAILED LOW (LOW VOLTAGE)

STEP/SEQUENCE	RESULT	WHAT TO DO NEXT
<p>36-8 Check for Open +5 Volt Line</p> <ul style="list-style-type: none"> • Turn ignition off. • Disconnect the engine harness connector at the ECM. • Install a jumper wire between sockets A and C of the OPS connector. • Read resistance between sockets W1 and Y2 on the engine harness connector. 	<p>Less than or equal to 5 ohms. →</p> <p>Greater than 5 ohms or open. →</p>	<p>Go to 36-9.</p> <p>The engine +5 volt line (ckt #416) is open. Repair open. Then go to 36-30.</p>
<p>36-9 Check for Short</p> <ul style="list-style-type: none"> • Remove jumper wire. • Read resistance between sockets A and C of the OPS connector. 	<p>Less than or equal to 10,000 ohms. →</p> <p>Greater than 10,000 ohms or open. →</p>	<p>The engine +5 volt line (ckt #416) is shorted to the return line (ckt #452). Repair short. Then go to 36-12.</p> <p>Go to 36-12.</p>
<p>36-10 Check for Short to Battery +</p> <ul style="list-style-type: none"> • Disconnect batteries (para 7-61). • Disconnect the vehicle harness and 5-way power harness connectors at the ECM. • Read resistance between socket P2 of the engine harness connector and socket B3 of the vehicle harness connector. • Also read resistance between socket P2 on the engine harness connector and the following sockets on the 5-way power harness connector: A and C. 	<p>All readings are greater than 10,000 ohms or open. →</p> <p>Any reading is less than or equal to 10,000 ohms. →</p>	<p>Go to 36-12.</p> <p>A short exists between the sockets where less than 10,000 ohms resistance was read. Repair short and connect batteries. Then go to 36-30.</p>

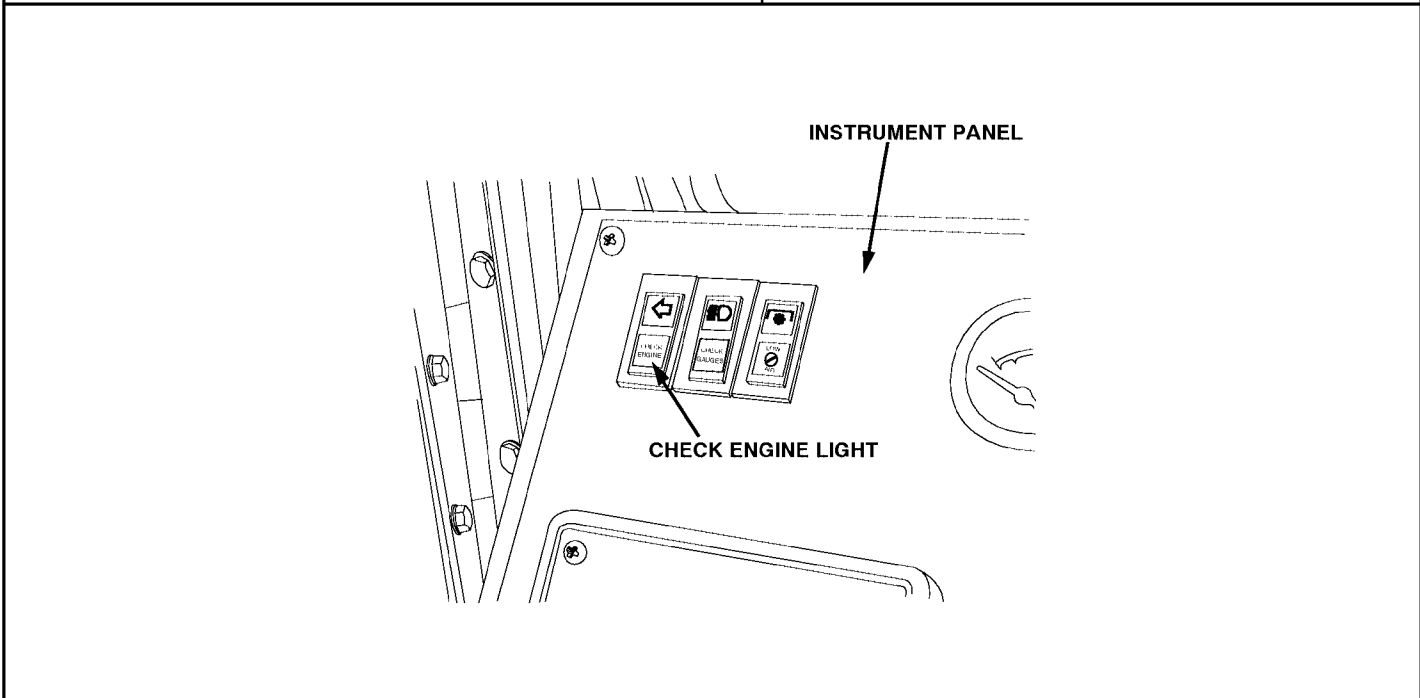
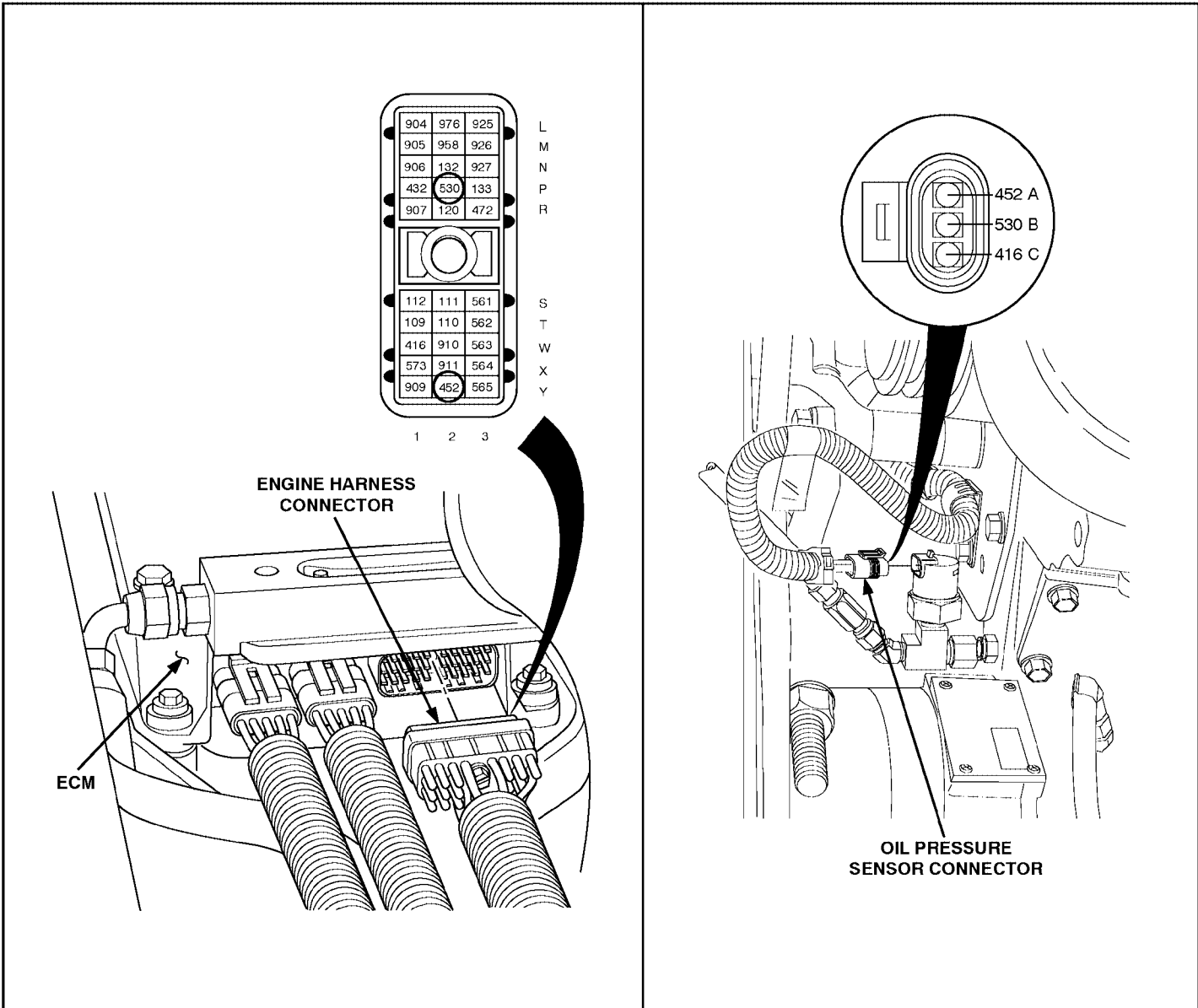

Section 4 TROUBLESHOOTING CHARTS

E. FLASH CODE: 36
J1587 CODE: P100 4 - OIL PRESSURE CIRCUIT FAILED LOW (LOW VOLTAGE)

STEP/SEQUENCE	RESULT	WHAT TO DO NEXT
<p>36-11 Check for Short on Ground</p> <ul style="list-style-type: none"> • Turn ignition off. • Remove jumper wires. • Measure resistance between sockets P2 and Y2 on the engine harness. 	<p>Greater than 10,000 ohms. →</p> <p>Less than or equal to 10,000 ohms. →</p>	<p>Go to 36-6.</p> <p>Signal line (ckt #530) and return line (ckt #452) are shorted together. Repair short. Then go to 36-30.</p>
<p>36-12 Replace OPS</p> <ul style="list-style-type: none"> • Turn ignition off. • Replace OPS (para 7-35.1). • Reconnect all connectors. • Turn ignition on. • Clear codes. • Start engine (TM 9-2320-360-10). Run until "Check Engine" light comes on or for 1 minute. 	<p>Check engine light comes on. →</p> <p>Check engine light does not come on. →</p>	<p>Go to 36-7.</p> <p>Go to 36-30.</p>
<p>36-30 Verify Repairs</p> <ul style="list-style-type: none"> • Turn ignition off. • Reconnect all connectors. • Turn ignition on. • Clear codes. • Note status of "Check Engine" light. • If "Check Engine" light does not stay on, start engine and run (TM 9-2320-360-10) until "Check Engine" light comes on or engine has run warm (greater than 60 degrees C, 140 degrees F) 1 minute. • Read inactive codes. 	<p>No codes. →</p> <p>Code 100/4 (and any other codes). →</p> <p>Any other codes except Code 100/4. →</p>	<p>Repairs are complete.</p> <p>All system diagnostics are complete. Please review this section from the start to find the error.</p> <p>Go to START-1, pg H-25, to service other codes.</p>

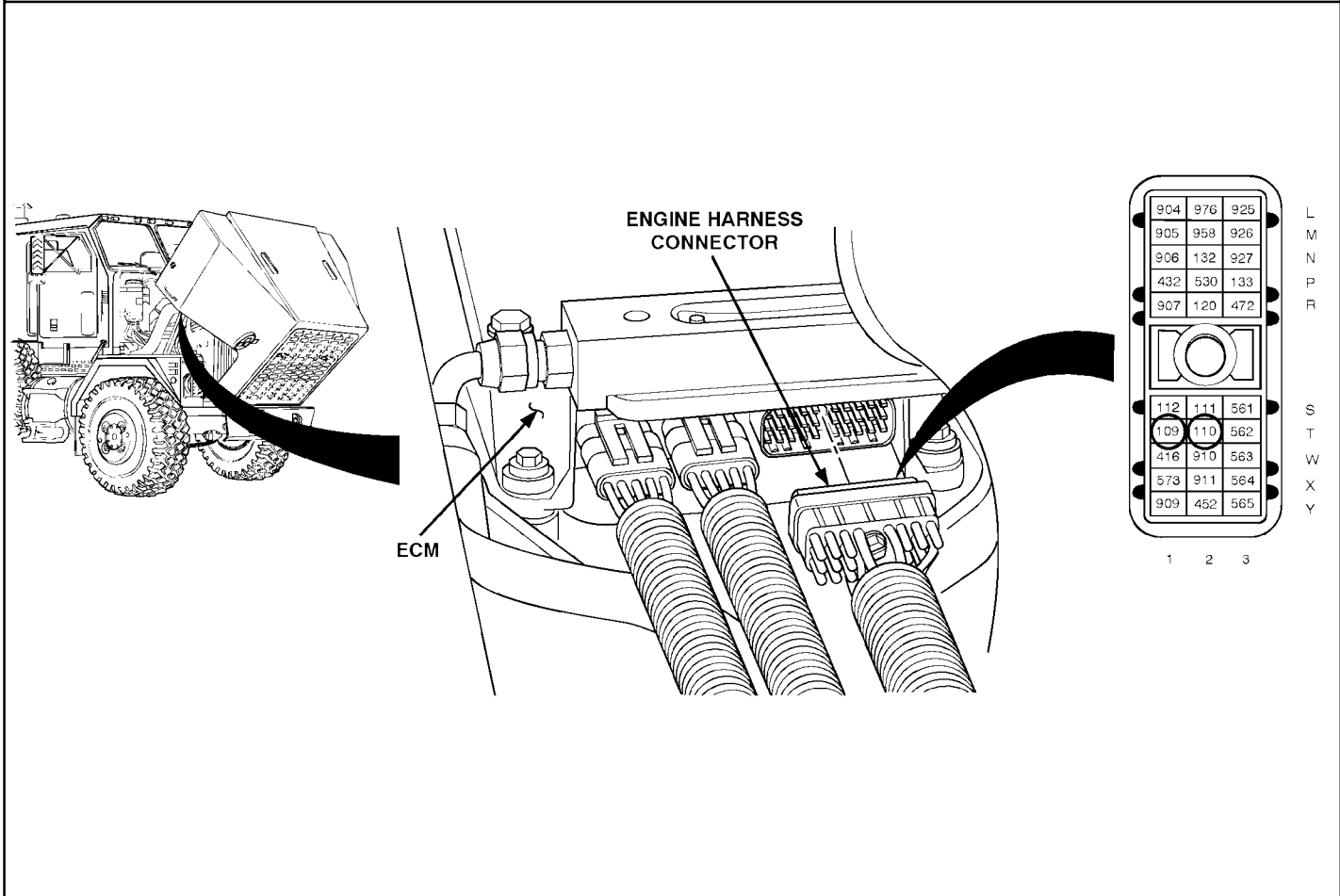
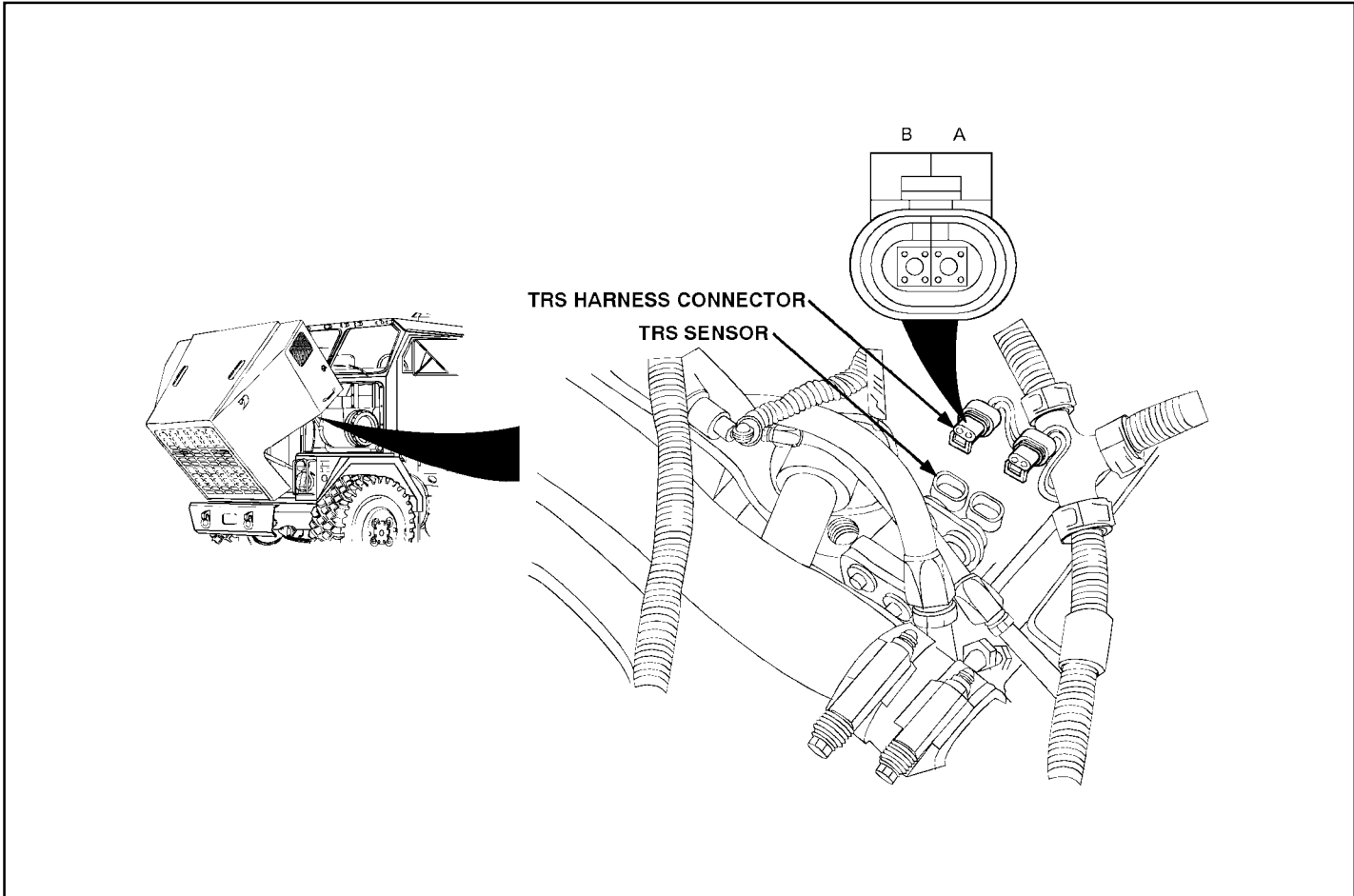

Section 4 TROUBLESHOOTING CHARTS

E. FLASH CODE: 41
J1587 CODE: S21 0 - TOO MANY SRS (MISSING TRS)

NOTE - This chart is only to be used if:

- 1) All basic mechanical checks and physical inspections have been performed with no problem found, and
- 2) Diagnosis of DDEC-III/IV was started at step START-1, pg H-25 and you have now been referred here.





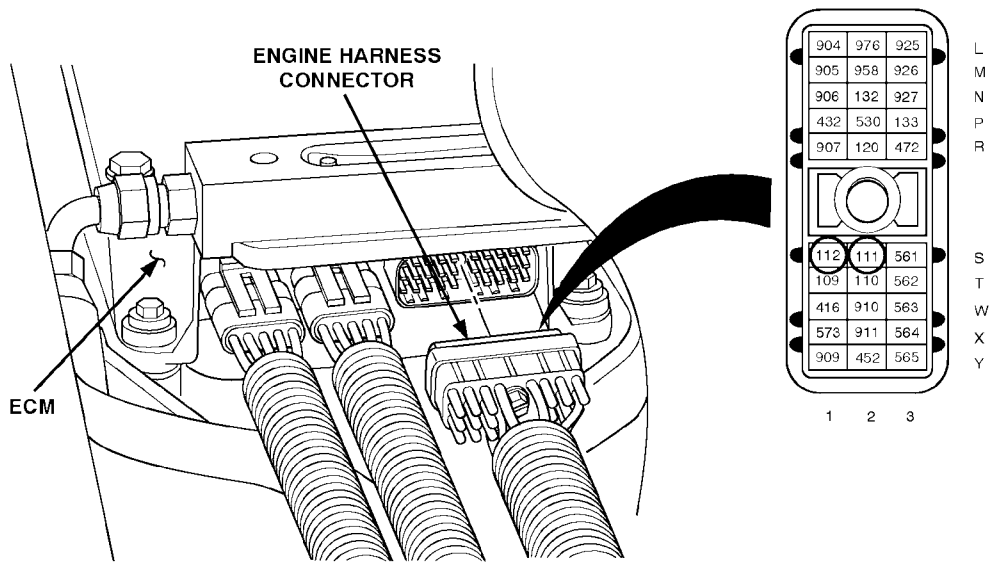
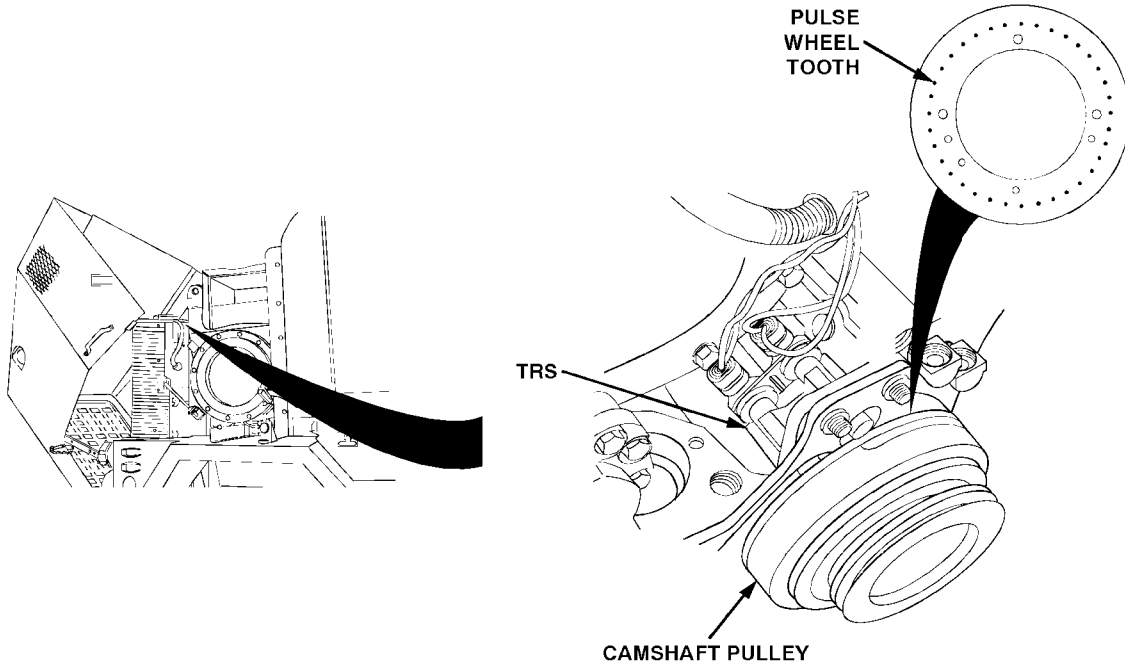



NOTE - ECM must be removed (para 7-29.1) for access to TRS/SRS connectors.

STEP/SEQUENCE	RESULT	WHAT TO DO NEXT
<p>41-5 Resistance Check</p> <ul style="list-style-type: none"> • Turn ignition off. • Disconnect engine harness connector at ECM. • Read resistance between socket T1 and T2 on engine harness connector. 	<p>Less than or equal to 200 ohms. → Go to 41-6.</p> <p>Greater than 200 ohms or open. → Go to 41-3.</p>	
<p>41-6 Check for Short</p> <ul style="list-style-type: none"> • Disconnect TRS connector. • Read resistance between sockets T1 and T2 on the engine harness connector. • Also read resistance between socket T1 and ground, then between socket T2 and ground. 	<p>Less than or equal to 10,000 ohms on any reading. → A short exists between (ckt #110) and (ckt #109) or where resistance was less than 10,000 ohms. Repair short. Then go to 41-30.</p> <p>Greater than 10,000 ohms or open on all readings. → Go to 41-4.</p>	
<p>41-7 Open TRS Line Check</p> <ul style="list-style-type: none"> • Disconnect TRS connector and install a jumper wire between sockets A and B of the TRS connector. • Read resistance between sockets T1 and T2 on the engine harness connector. 	<p>Less than or equal to 5 ohms. → Go to 41-4.</p> <p>Greater than 5 ohms or open. → Signal line (ckt #110) or return and (ckt #109) is open. Repair open. Then go to 41-30.</p>	
<p>41-8 Check TRS Resistance</p> <ul style="list-style-type: none"> • Read resistance of TRS across sensor pins A and B. 	<p>Less than 100 ohms. → Go to 41-12.</p> <p>From 100 to 200 ohms. → Go to 41-5.</p> <p>Greater than 200 ohms. → Go to 41-12.</p>	



Section 4 TROUBLESHOOTING CHARTS

E. FLASH CODE: 41
J1587 CODE: S21 0 - TOO MANY SRS (MISSING TRS)

STEP/SEQUENCE	RESULT	WHAT TO DO NEXT
41-5 Check TRS/SRS Gap <ul style="list-style-type: none"> • Turn camshaft counterclockwise until TRS is over a TRS "tooth" of pulse wheel. • Tap the front of pulse wheel rearward with a soft hammer (to remove camshaft end play). • Install TRS/SRS alignment tool and check gap. (nominal gap 0.020" or 0.5 mm). 	Incorrect gap.  Gap setting is correct. 	Loosen the screw at top of TRS/SRS mounting bracket. (Don't touch the two screws that go into block front end plate -they will affect engine timing.) Adjust the TRS/SRS until gap setting is correct. Tighten screw. (If problem returns, pulse wheel may be loose or bad, notify supervisor). Then go to 41-30. Go to 41-6.
41-6 Check for SRS Code <ul style="list-style-type: none"> • Was there also a Code 21/1? 	Yes.  No. 	Go to 41-8. Go to 41-15.
41-7 Check ECM Connectors <ul style="list-style-type: none"> • Check terminals at engine harness connector (both ECM and harness side) for damage, corrosion, and unseated pins or sockets. 	Terminals and connectors are okay.  Problem found. 	Replace ECM (para 7-29.1). Then go to 41-30. Repair terminals/connectors (para 7-77). Then go to 41-30.
41-8 SRS Resistance Check <ul style="list-style-type: none"> • Read resistance between sockets S1 and S2 on engine harness connector. 	Less than or equal to 200 ohms.  Greater than 200 ohms or open. 	Go to 41-9. Go to 41-10.

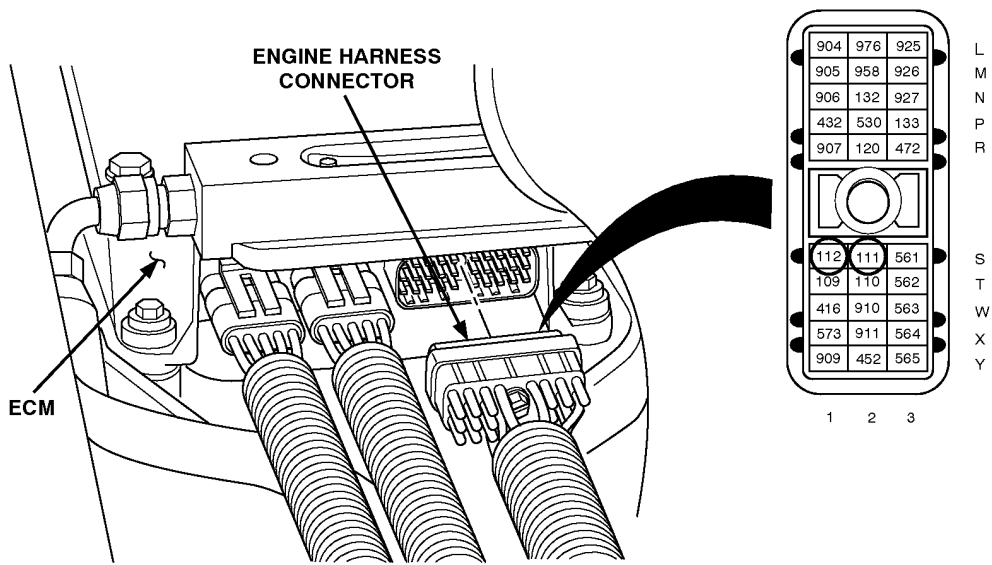
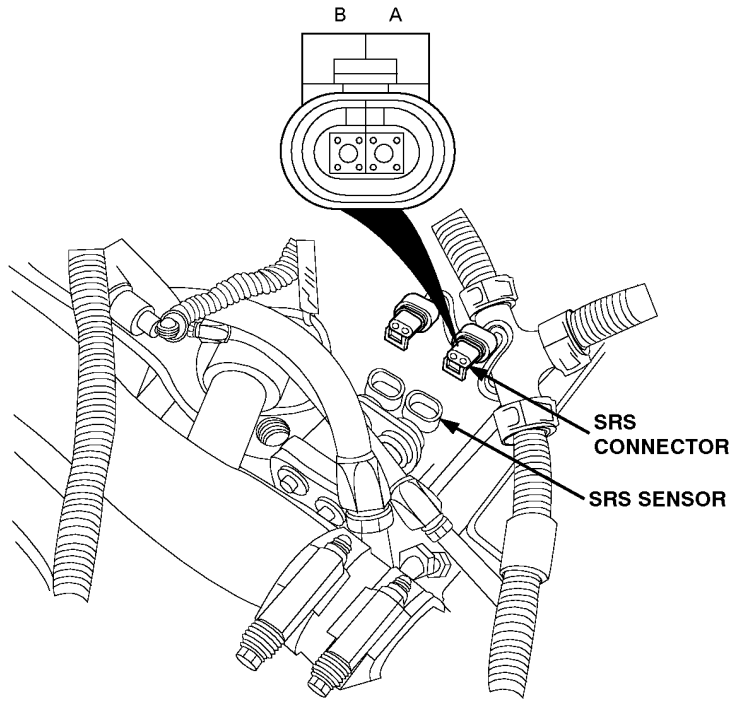

Section 4 TROUBLESHOOTING CHARTS

E. FLASH CODE: 41
 J1587 CODE: S21 0 - TOO MANY SRS (MISSING TRS)

STEP/SEQUENCE	RESULT	WHAT TO DO NEXT
<p>41-9 Check for Short</p> <ul style="list-style-type: none"> • Disconnect SRS connector. • Read resistance between sockets S1 and S2 on engine harness connector. 	<p>Less than or equal to 10,000 ohms. →</p> <p>Greater than 10,000 ohms or open. →</p>	<p>Signal line (ckt #111) is shorted to return line (ckt #112). Repair short. Then go to 41-30.</p> <p>Go to 41-11.</p>
<p>41-10 Open SRS Line Check</p> <ul style="list-style-type: none"> • Install a jumper wire between sockets A and B of SRS connector. • Read resistance between sockets S1 and S2 of engine harness connector. 	<p>Less than or equal to 5 ohms. →</p> <p>Greater than 5 ohms or open. →</p>	<p>Go to 41-11.</p> <p>Signal line (ckt #111) or return line (ckt #112) is open. Repair open. Then go to 41-30.</p>
<p>41-11 SRS Test</p> <ul style="list-style-type: none"> • Read resistance of the SRS across the sensor pins A and B. 	<p>Less than 100 ohms. →</p> <p>From 100 to 200 ohms. →</p> <p>Greater than 200 ohms. →</p>	<p>Go to 41-13.</p> <p>Go to 41-7.</p> <p>Go to 41-13.</p>
<p>41-12 Check TRS Connectors</p> <ul style="list-style-type: none"> • Check connectors at the TRS (both the harness side and the TRS side) for damage; bent, corroded or unseated pins or sockets, or bad contacts. 	<p>Connectors are okay. →</p> <p>Problem found. →</p>	<p>TRS requires replacement. Notify supervisor. Then go to 41-14.</p> <p>Repair terminals/connectors (para 7-77). Then go to 41-30.</p>

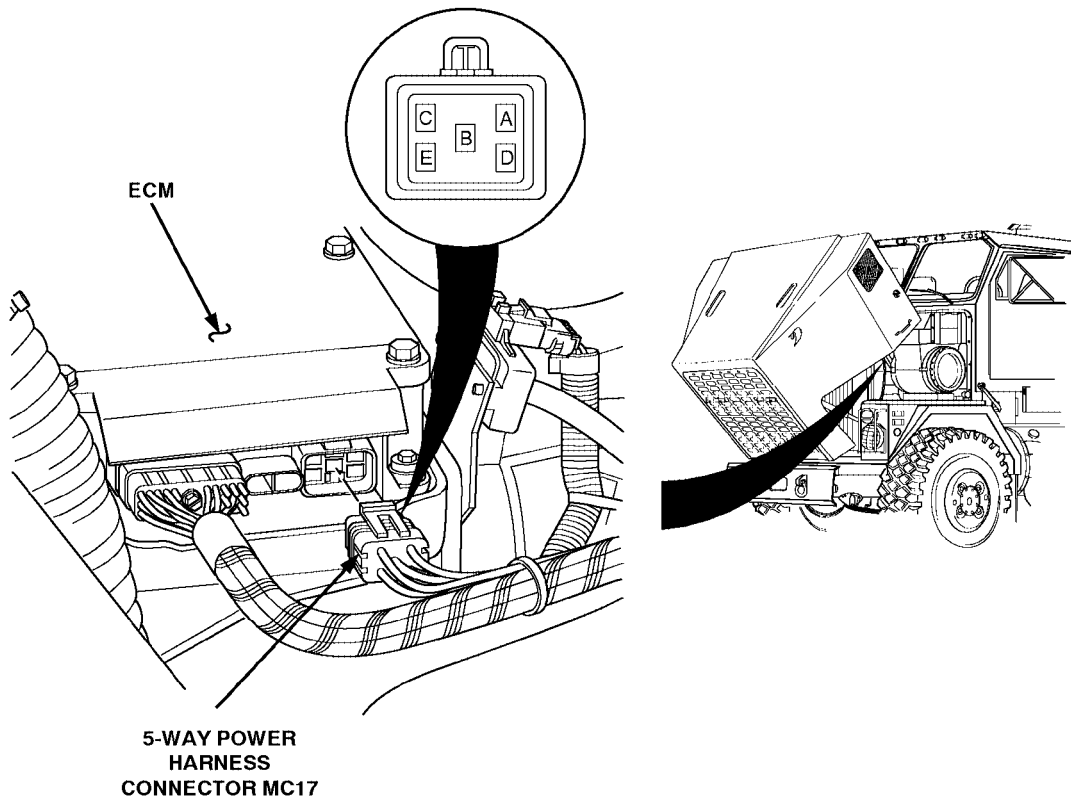
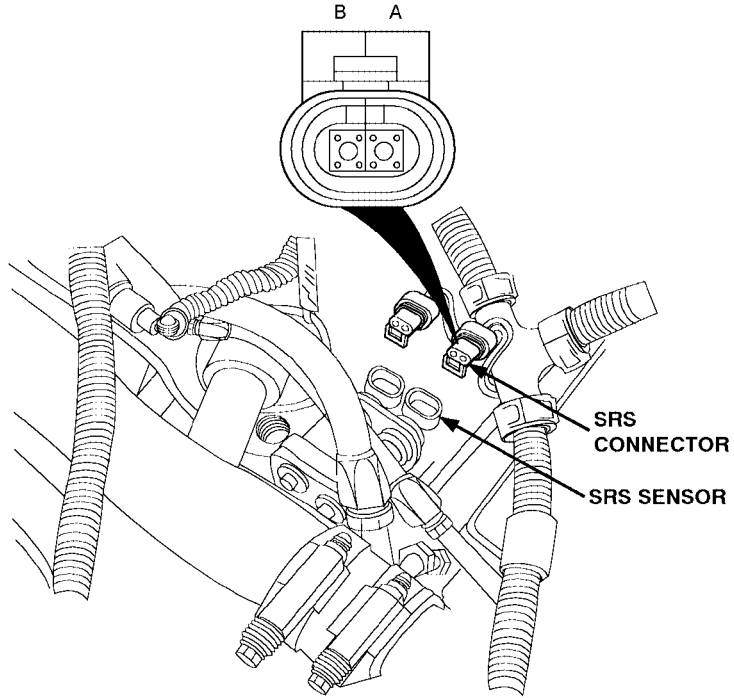

Section 4 TROUBLESHOOTING CHARTS

E. FLASH CODE: 41
J1587 CODE: S21 0 - TOO MANY SRS (MISSING TRS)

STEP/SEQUENCE	RESULT	WHAT TO DO NEXT
<p>41-13 Check SRS Connectors</p> <ul style="list-style-type: none"> • Check connectors at the SRS (both the harness side and the sensor side) for damage; bent, corroded or unseated pins or sockets, or bad contacts. 	<p>Connectors are okay. →</p> <p>Problem found. →</p>	<p>SRS requires replacement. Notify supervisor. Then go to 41-14.</p> <p>Repair terminals/connectors (para 7-77). Then go to 41-30.</p>
<p>41-14 Verify SRS/TRS</p> <ul style="list-style-type: none"> • Turn ignition off. • Reconnect all connectors. • Turn ignition on. • Clear codes (TM 9-2320-360-10). • Start and run engine until the "Check Engine" light comes on or for 1 minute. • Stop engine. • Read inactive codes. 	<p>No codes. →</p> <p>Code 21/0 reappears (and any other codes). →</p> <p>Code(s) other than Code 21/0 received. →</p>	<p>Repairs are complete.</p> <p>If the SRS was just replaced, go to 41-15. If the SRS was not replaced, go to 41-6.</p> <p>Go to START-1, pg H-25, to service other codes.</p>
<p>41-15 Check Cranking Voltage</p> <ul style="list-style-type: none"> • Turn ignition off. • Connect other connectors. • Fabricate temporary jumper harness per instructions in Appendix D, Figure D-24. • Connect jumper harness to fully charged battery (12 volt). • Connect jumper harness to ECM. • Turn ignition on. • Clear codes. • Start engine (TM 9-2320-360-10). Run until "Check Engine" light comes on or for 1 minute. • Stop engine. • Read active codes. 	<p>Engine won't start and/or Code 21/0 (and any other codes). →</p> <p>Engine starts and no Code 21/0. →</p>	<p>Go to 41-7.</p> <p>Service discharged battery (TM 9-6140-200-14). Repair, then to go 41-30.</p>

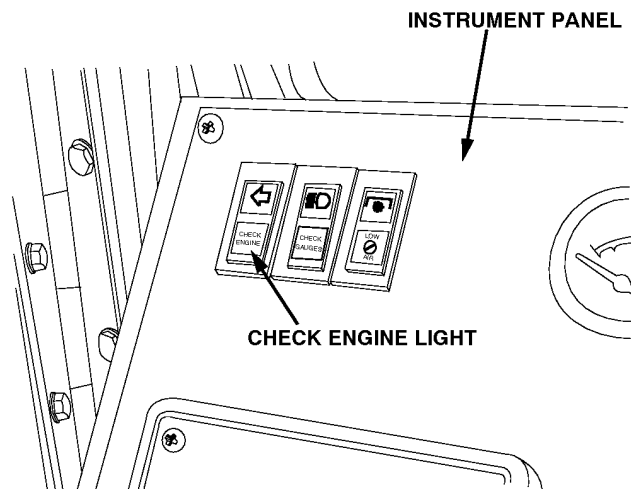

Section 4 TROUBLESHOOTING CHARTS

E. FLASH CODE: 41
 J1587 CODE: S21 0 - TOO MANY SRS (MISSING TRS)

STEP/SEQUENCE	RESULT	WHAT TO DO NEXT
<p>41-30 Verify Repairs</p>		
<ul style="list-style-type: none"> • Turn ignition off. • Reconnect all connectors. • Turn ignition on. • Clear codes. • Note status of "Check Engine" light. • If "Check Engine" light does not stay on, start engine and run (TM 9-2320-360-10) until "Check Engine" light comes on or for 1 minute. • Stop engine. • Read inactive codes. 	<p>No codes. →</p> <p>Code 21/0 (and any other codes). →</p> <p>Any other codes except Code 21/0. →</p>	<p>Repairs are complete.</p> <p>All system diagnostics are complete. Please review this section from the start to find error.</p> <p>Go to START-1, pg H-25 to service other codes.</p>

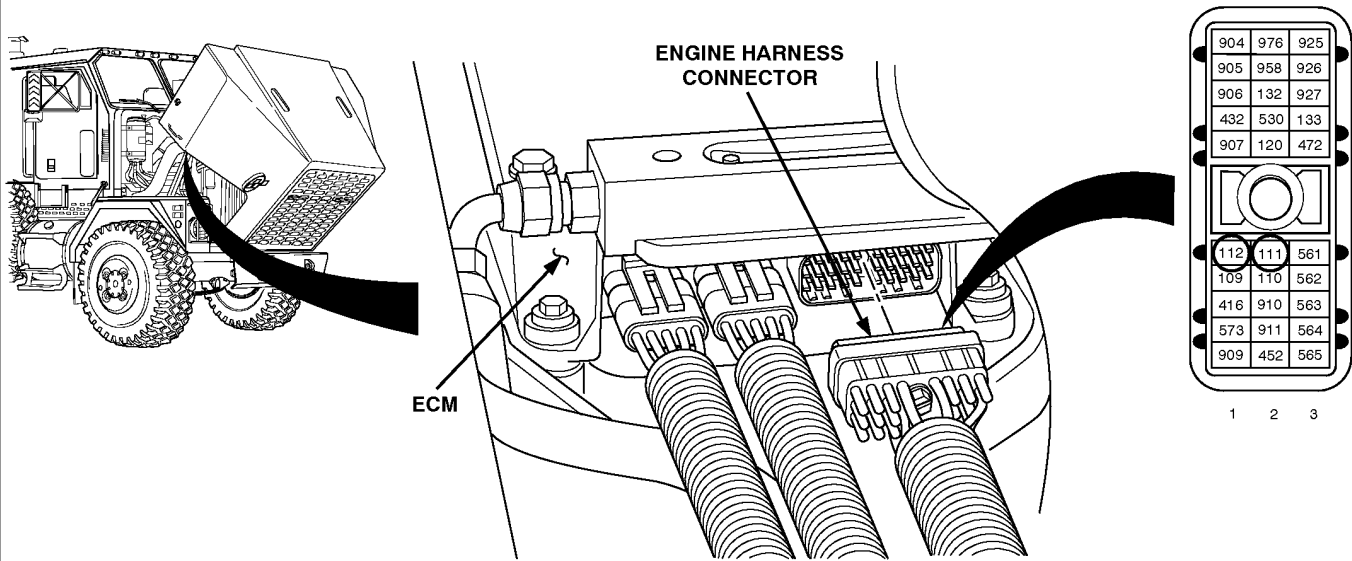
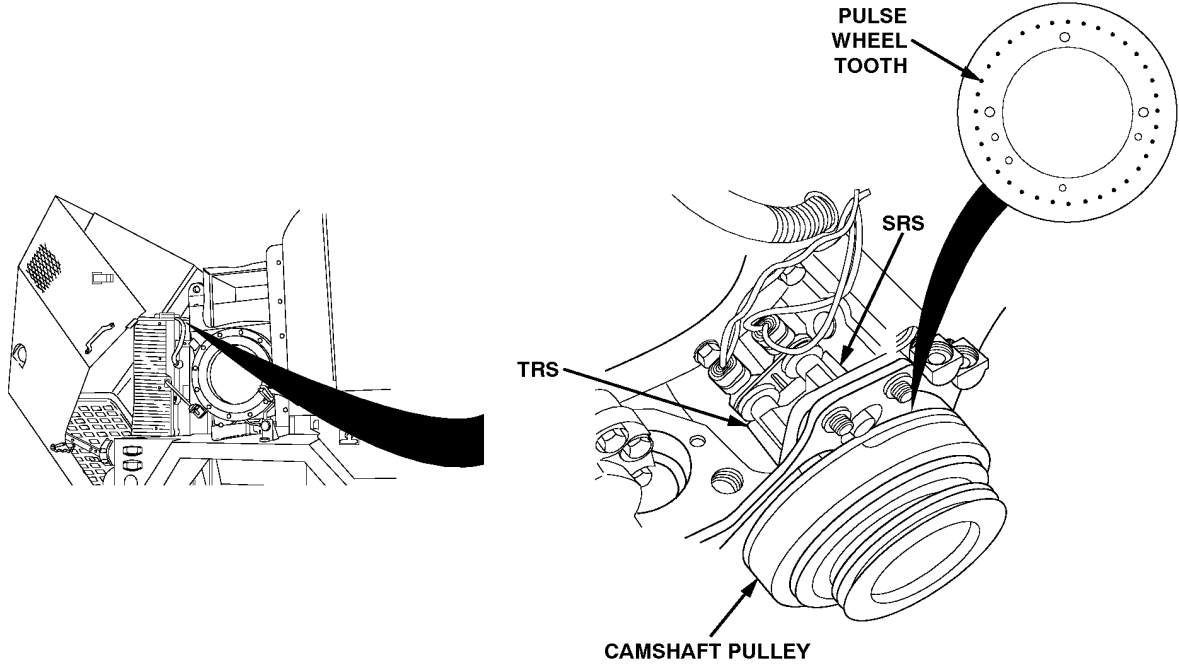

Section 4 TROUBLESHOOTING CHARTS

E. FLASH CODE: 42
J1587 CODE: S21 1 - TOO FEW SRS (MISSING SRS)

NOTE - This chart is only to be used if:

- 1) All basic mechanical checks and physical inspections have been performed with no problem found, and
- 2) Diagnosis of DDEC-III/IV was started at step START-1, pg H-25 and you have now been referred here.

NOTE - ECM must be removed (para 7-29.1) for access to TRS/SRS connectors.

STEP/SEQUENCE	RESULT	WHAT TO DO NEXT
<p>42-1 Resistance Check</p> <ul style="list-style-type: none"> • Turn ignition off. • Disconnect engine harness connector at ECM. • Read resistance between socket S1 and S2 on engine harness connector. 	<p>Less than or equal to 200 ohms. → Go to 42-2.</p> <p>Greater than 200 ohms or open. → Go to 42-3.</p>	
<p>42-2 Check for Short</p> <ul style="list-style-type: none"> • Disconnect SRS connector. • Read resistance between sockets S1 and S2 on engine harness connector. • Also read resistance between socket S1 and ground, then between socket S2 and ground. 	<p>Less than or equal to 10,000 ohms on any reading. → A short exists where resistance was less than 10,000 ohms. Repair short. Then go to 42-30.</p> <p>Greater than 10,000 ohms or open on all readings. → Go to 42-4.</p>	
<p>42-3 Open SRS Line Check</p> <ul style="list-style-type: none"> • Disconnect SRS connector and install a jumper wire between sockets A and B of the SRS connector. • Read resistance between sockets S1 and S2 on the engine harness connector. 	<p>Less than or equal to 5 ohms. → Go to 42-4.</p> <p>Greater than 5 ohms or open. → Signal line (ckt #111) or return line (ckt #112) is open. Repair open. Then go to 42-30.</p>	
<p>42-4 Check SRS Resistance</p> <ul style="list-style-type: none"> • Read resistance of SRS across sensor pins A and B. 	<p>Less than 100 ohms. → Go to 42-12.</p> <p>From 100 to 200 ohms. → Go to 42-5.</p> <p>Greater than 200 ohms. → Go to 42-12.</p>	

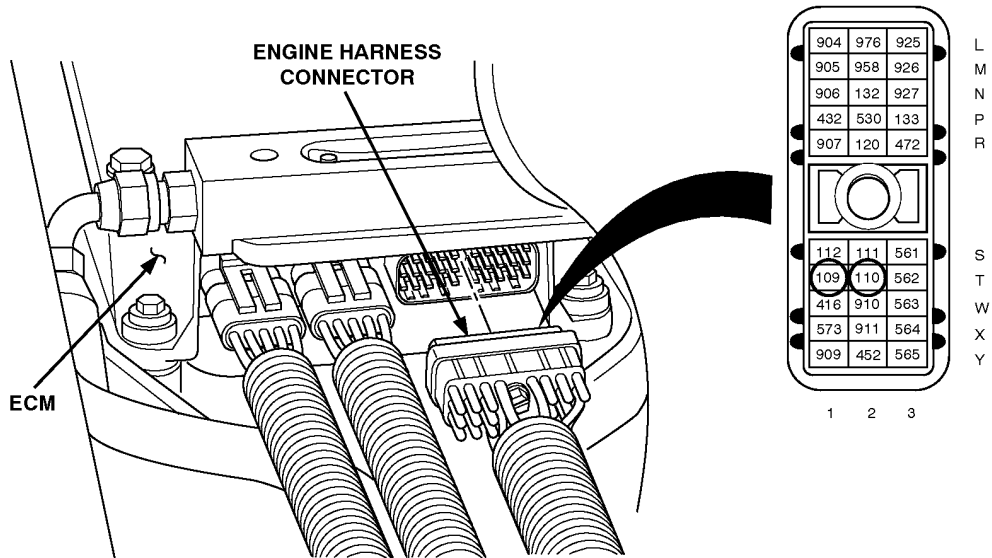
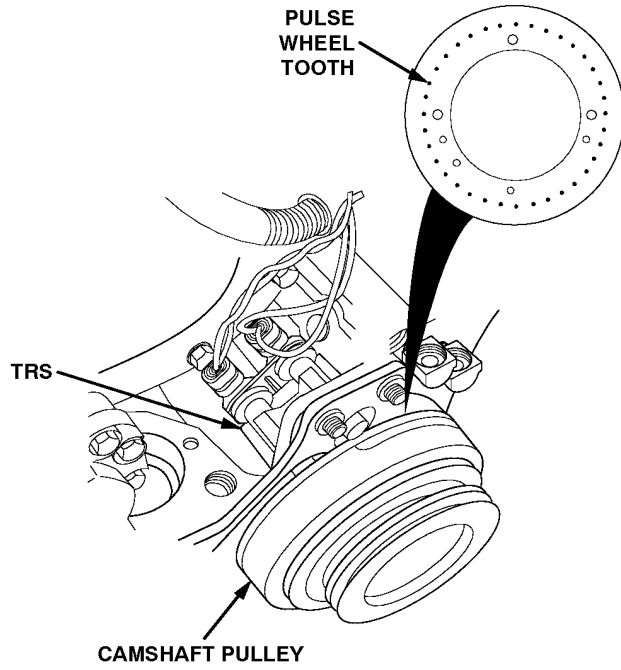

Section 4 TROUBLESHOOTING CHARTS

E. FLASH CODE: 42
 J1587 CODE: S21 1 - TOO FEW SRS (MISSING SRS)

STEP/SEQUENCE	RESULT	WHAT TO DO NEXT
<p>42-5 Check TRS/SRS Gap</p> <ul style="list-style-type: none"> • Turn camshaft counterclockwise until TRS is over a TRS "tooth" of pulse wheel. • Tap the front of pulse wheel rearward with a soft hammer (to remove camshaft end play). • Install TRS/SRS alignment tool and check gap. (nominal gap 0.020" or 0.5 mm). 	<p>Incorrect gap. →</p> <p>Gap setting is correct. →</p>	<p>Loosen the screw at top of TRS/SRS mounting bracket. (Don't touch the two screws that go into block front end plate -they will affect engine timing.) Adjust the TRS/SRS until gap setting is correct. Tighten screw. (If problem returns, pulse wheel may be loose or bad, notify supervisor). Then go to 42-30.</p> <p>Go to 42-6.</p>
<p>42-6 Check for TRS Code</p> <ul style="list-style-type: none"> • Was there also a Code 21/0? 	<p>Yes. →</p> <p>No. →</p>	<p>Go to 42-8.</p> <p>Go to 42-7.</p>
<p>42-7 Check ECM Connectors</p> <ul style="list-style-type: none"> • Check terminals at engine harness connector (both ECM and harness side) for damage, corrosion, and unseated pins or sockets. 	<p>Terminals and connectors are okay. →</p> <p>Problem found. →</p>	<p>Then go to 42-15.</p> <p>Repair terminals/connectors (para 7-77). Then go to 42-30.</p>
<p>42-8 TRS Resistance Check</p> <ul style="list-style-type: none"> • Read resistance between sockets T1 and T2 on engine harness connector. 	<p>Less than or equal to 200 ohms. →</p> <p>Greater than 200 ohms or open. →</p>	<p>Go to 42-9.</p> <p>Go to 42-10.</p>

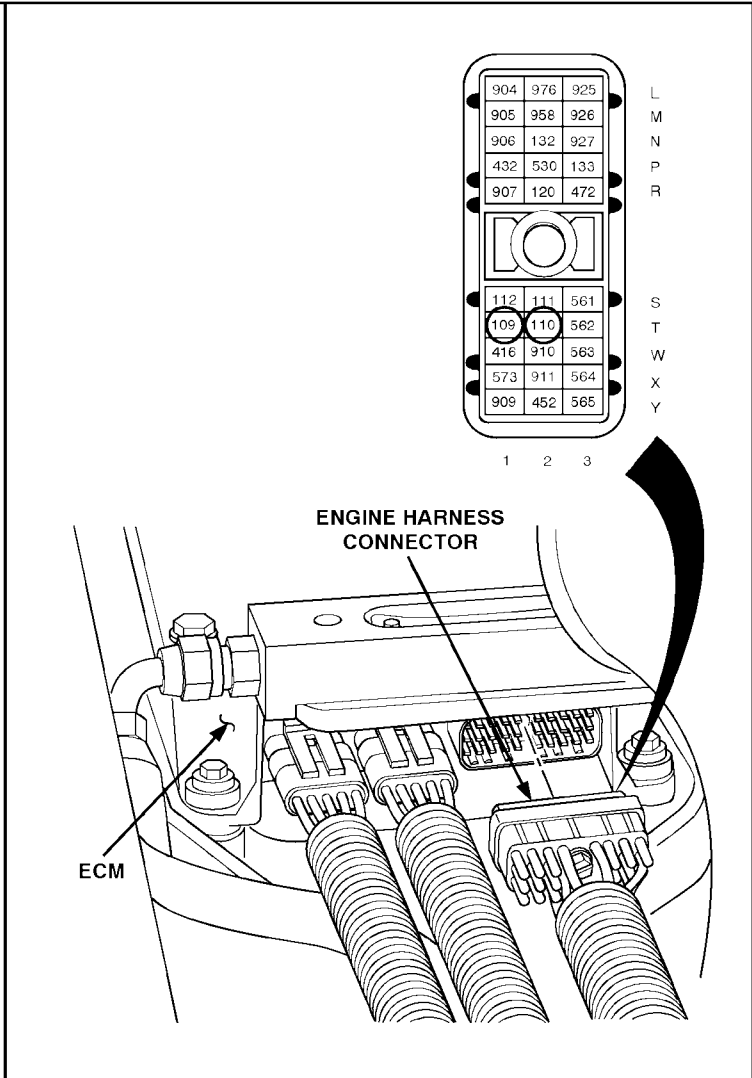
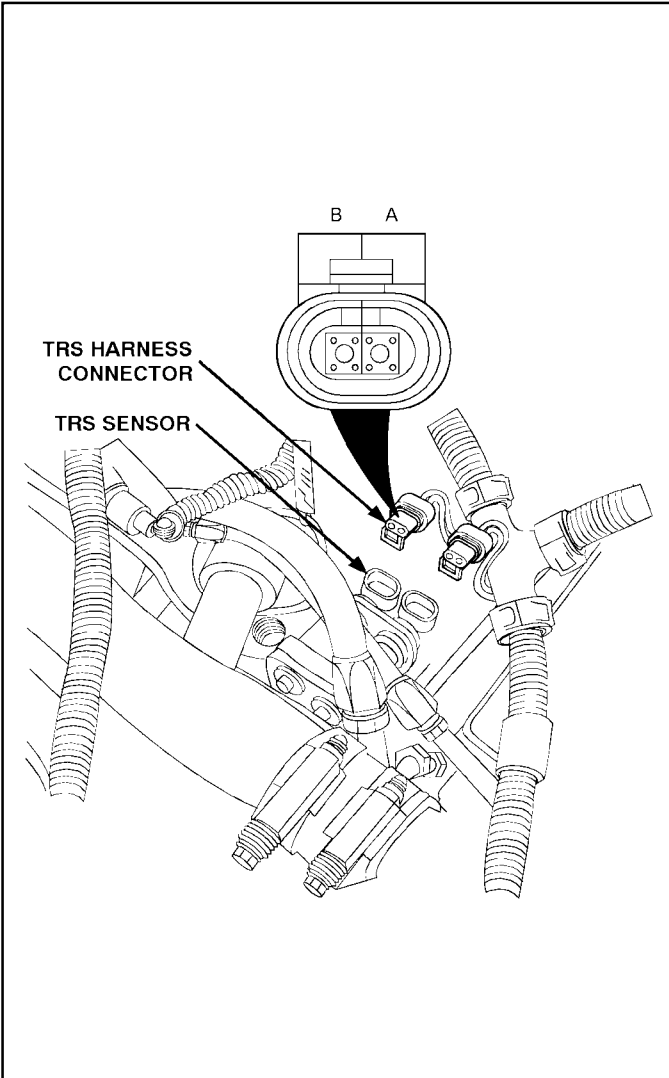

904	976	925	L M N P R
905	958	926	
906	132	927	
432	530	133	
907	120	472	
			S T W X Y
112	111	561	
109	110	562	
416	910	563	
573	911	564	
909	452	565	
1 2 3			

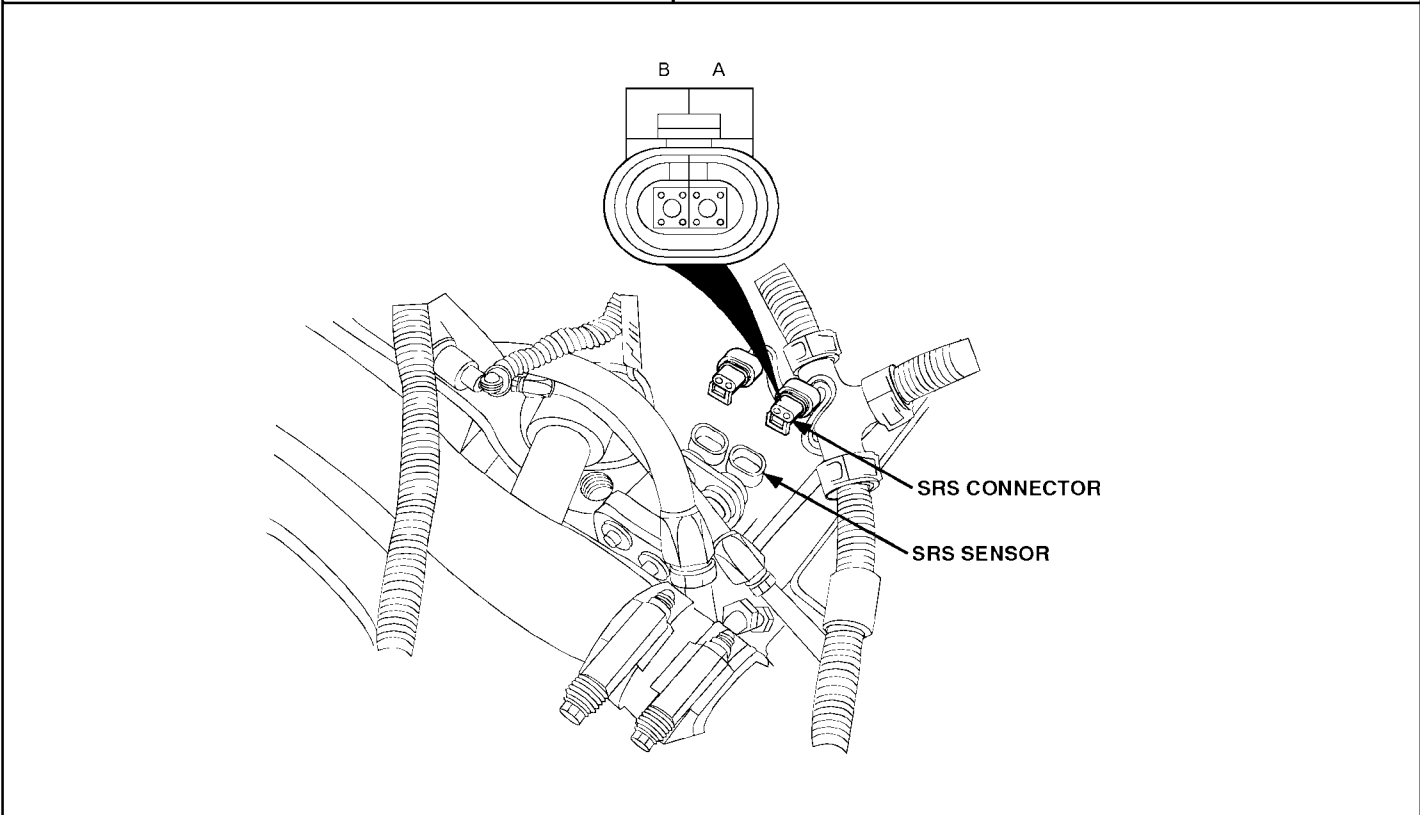

Section 4 TROUBLESHOOTING CHARTS

E. FLASH CODE: 42
J1587 CODE: S21 1 - TOO FEW SRS (MISSING SRS)

STEP/SEQUENCE	RESULT	WHAT TO DO NEXT
<p>42-9 Check for Short</p> <ul style="list-style-type: none"> • Disconnect TRS connector. • Read resistance between sockets T1 and T2 on engine harness connector. 	<p>Less than or equal to 10,000 ohms. →</p> <p>Greater than 10,000 ohms or open. →</p>	<p>Signal line (ckt #110) is shorted to return line (ckt #109). Repair short. Then go to 42-30.</p> <p>Go to 42-11.</p>
<p>42-10 Open TRS Line Check</p> <ul style="list-style-type: none"> • Install a jumper wire between sockets A and B of TRS connector. • Read resistance between sockets T1 and T2 of engine harness connector. 	<p>Less than or equal to 5 ohms. →</p> <p>Greater than 5 ohms or open. →</p>	<p>Go to 42-11.</p> <p>Signal line (ckt #110) or return line (ckt #109) is open. Repair open. Then go to 42-30.</p>
<p>42-11 TRS Test</p> <ul style="list-style-type: none"> • Read resistance of TRS across sensor connector pins A and B. 	<p>Less than or 100 ohms. →</p> <p>From 100 to 200 ohms. →</p> <p>Greater than 200 ohms. →</p>	<p>Go to 42-13.</p> <p>Go to 42-7.</p> <p>Go to 42-13.</p>
<p>42-12 Check SRS Connectors</p> <ul style="list-style-type: none"> • Check connectors at SRS (both harness side and SRS side) for corrosion, damaged or unseated pins or sockets, or bad contacts. 	<p>Connectors are okay. →</p> <p>Problem found. →</p>	<p>SRS requires replacement. Notify supervisor. Then go to 42-14.</p> <p>Repair terminals/connectors (para 7-77). Then go to 42-30.</p>

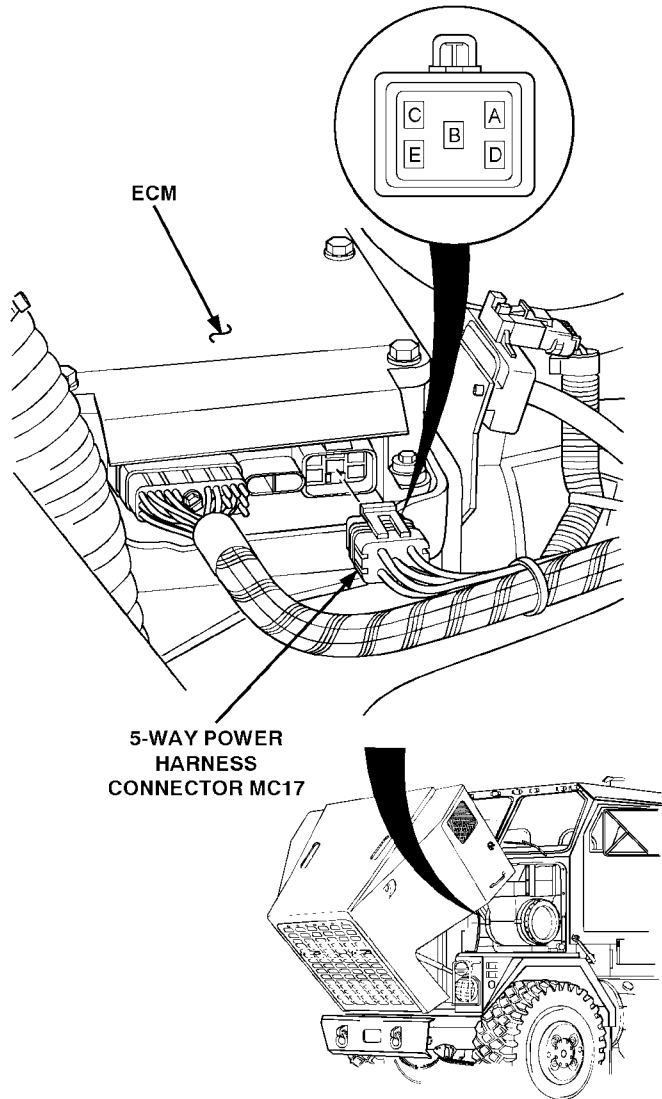
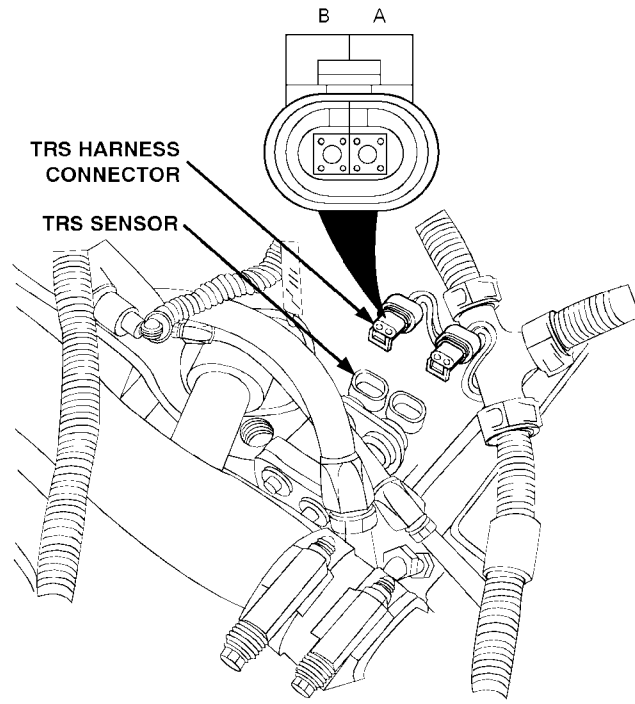

Section 4 TROUBLESHOOTING CHARTS

E. FLASH CODE: 42
J1587 CODE: S21 1 - TOO MANY SRS (MISSING SRS)

STEP/SEQUENCE	RESULT	WHAT TO DO NEXT
<p>42-13 Check TRS Connectors</p> <ul style="list-style-type: none"> • Check connectors at TRS (both harness side and sensor side) for damage; bent, corroded or unseated pins or sockets, or bad contracts. 	<p>Connectors are okay. →</p> <p>Problem found. →</p>	<p>TRS requires replacement. Notify supervisor. Then go to 42-14.</p> <p>Repair terminals/connectors (para 7-77). Then go to 42-30.</p>
<p>42-14 Verify SRS/TRS</p> <ul style="list-style-type: none"> • Turn ignition off. • Reconnect all connectors. • Clear codes. • Start and run (TM 9-2320-360-10) engine until "Check Engine" light comes on or for 1 minute. • Stop engine. • Read inactive codes. 	<p>No Codes. →</p> <p>Code 21/1 reappears (and any other codes.) →</p> <p>Code(s) other than Code 21/1 received. →</p>	<p>Repairs are complete.</p> <p>If TRS was just replaced, go to 42-7. If the TRS was not replaced, go to 42-6.</p> <p>Go to START-10, pg H-25, to service other codes.</p>
<p>42-15 Verify Cranking Voltage</p> <ul style="list-style-type: none"> • Turn ignition off. • Connect all connectors. • Fabricate temporary jumper harness per instructions in Appendix D, Figure D-24. • Connect jumper harness to fully charged battery (12 volt). • Connect jumper harness to ECM. • Try to start engine. 	<p>Engine starts. →</p> <p>Engine does not start. →</p>	<p>Service discharged battery (TM 9-6140-200-14). Then go to 42-30.</p> <p>Replace ECM (para 7-29.1). Then go to 42-30.</p>

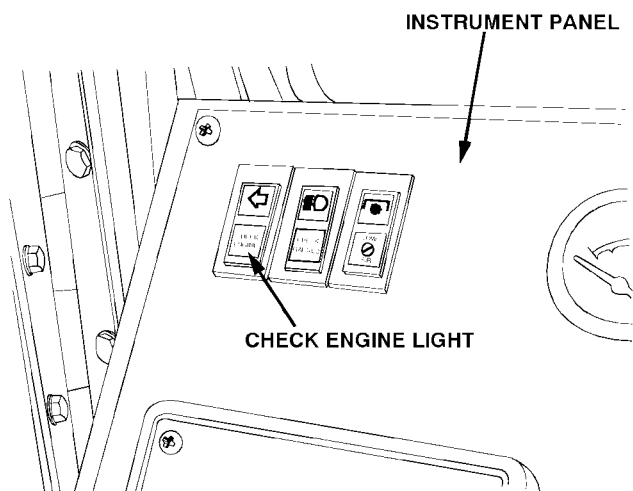

Section 4 TROUBLESHOOTING CHARTS

E. FLASH CODE: 42
 J1587 CODE: S21 1 - TOO FEW SRS (MISSING SRS)

STEP/SEQUENCE	RESULT	WHAT TO DO NEXT
<p>42-30 Verify Repairs</p>		
<ul style="list-style-type: none"> • Turn ignition off. • Reconnect all connectors. • Turn ignition on. • Clear codes. • Note status of "Check Engine" light. • If "Check Engine" light does not stay on, start engine and run (TM 9-2320-360-10) until "Check Engine" light comes on or for 1 minute. • Stop engine. • Read inactive codes. 	<p>No Codes. →</p> <p>Code 21/1 (and any other codes). →</p> <p>Any other codes except Code 21/1. →</p>	<p>Repairs are complete.</p> <p>All system diagnostics are complete. Please review this section from start to find error.</p> <p>Go to START-10, pg H-25, to service other codes.</p>

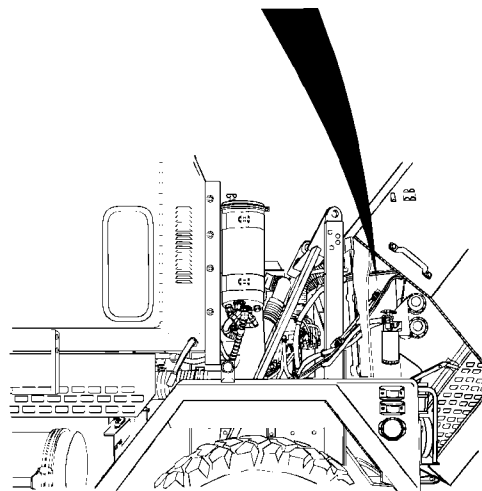
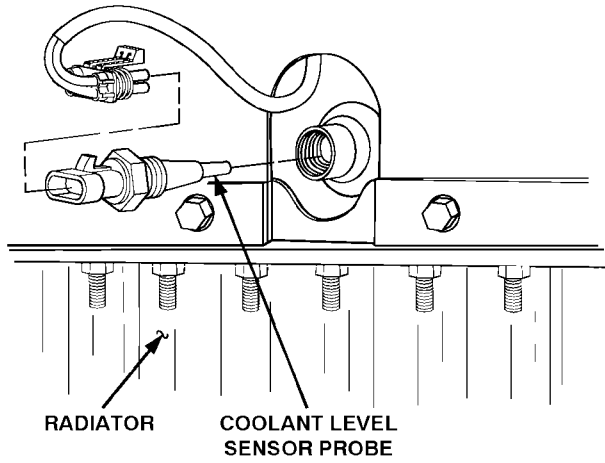

Section 4
TROUBLESHOOTING CHARTS

E. FLASH CODE: 43
J1587 CODE: P111 1 - COOLANT LEVEL LOW

NOTE - This chart is only to be used if:

- 1) All basic mechanical checks and physical inspections have been performed with no problem found, and
- 2) Diagnosis of DDEC-III/IV was started at step START-10, pg H-25 and you have now been referred here.

STEP/SEQUENCE	RESULT	WHAT TO DO NEXT
Code 111-1	Indicates a low coolant level condition.	Add coolant to ensure coolant level probe is immersed in coolant.

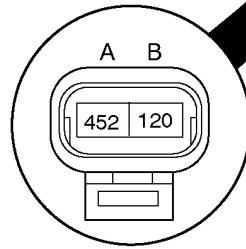
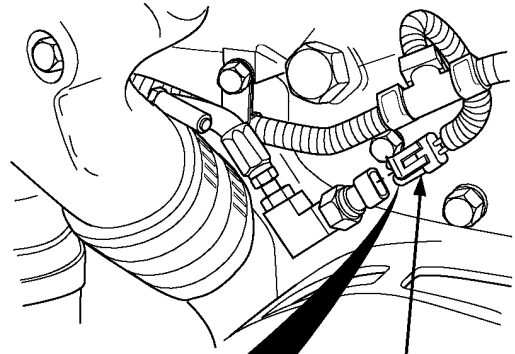
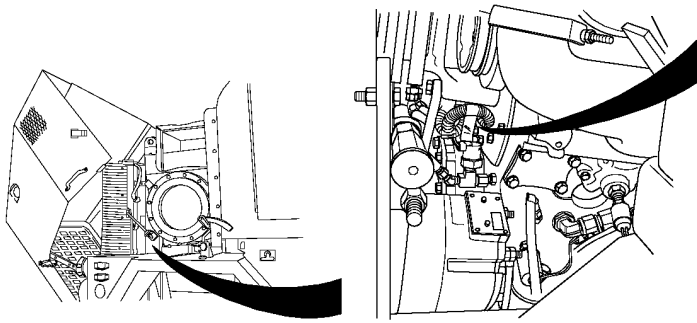

OIL TEMPERATURE
SENSOR CONNECTOR

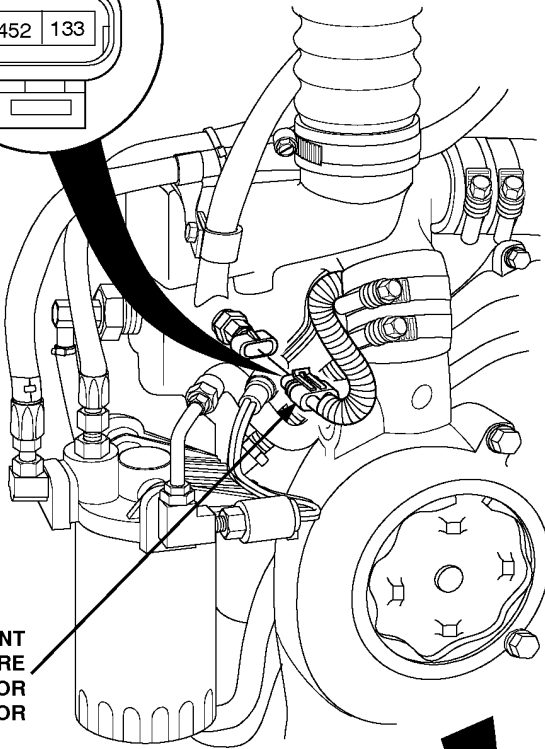
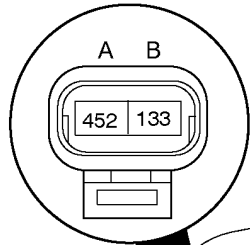

COOLANT
TEMPERATURE
SENSOR
CONNECTOR

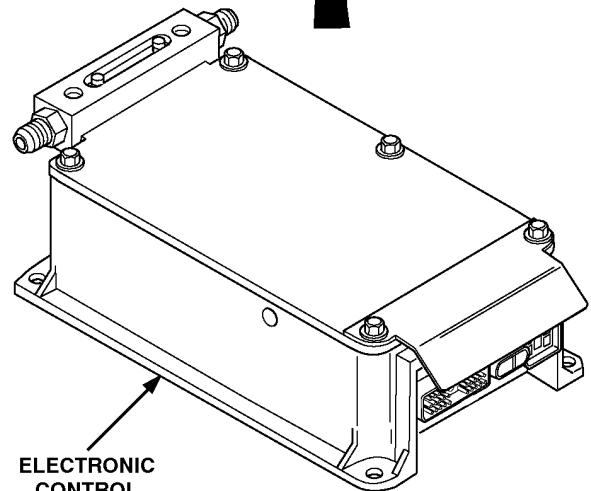
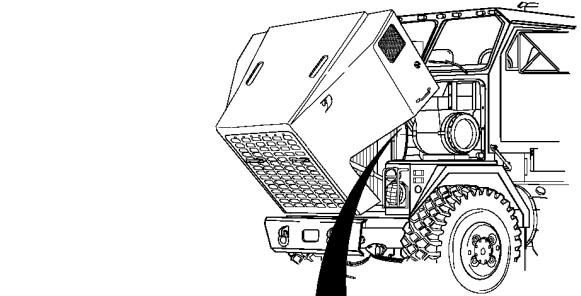
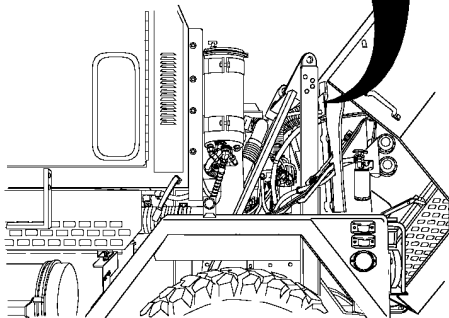

ELECTRONIC
CONTROL
MODULE

ECM SHOWN REMOVED FOR CLARITY

Section 4 TROUBLESHOOTING CHARTS

E. FLASH CODE: 44
J1587 CODE: P110 0 - COOLANT TEMPERATURE HIGH OR
P175 0 - OIL TEMPERATURE HIGH

NOTE - This chart is only to be used if:

- 1) All basic mechanical checks and physical inspections have been performed with no problem found, and
- 2) Diagnosis of DDEC-III/IV was started at step START-10, pg H-25 and you have now been referred here.

When (Inactive Codes) are displayed on DDR, additional audit trail information is also shown. For an understanding of this information refer to the example given in the Code 85 chart.

STEP/SEQUENCE	RESULT	WHAT TO DO NEXT
44-1 Multiple Code Check		
<ul style="list-style-type: none"> Were there any other codes besides 110/0 or 175/0? Plug in reader and determine if code is for high coolant or oil temperature. 	<p>Yes. </p> <p>No. </p>	<p>Service other codes first.</p> <p>This fault codes indicates oil or coolant temperature was higher than it should have been. Refer to Chapter 2, Vehicle Troubleshooting, to determine potential causes for high oil or coolant temperatures.</p>

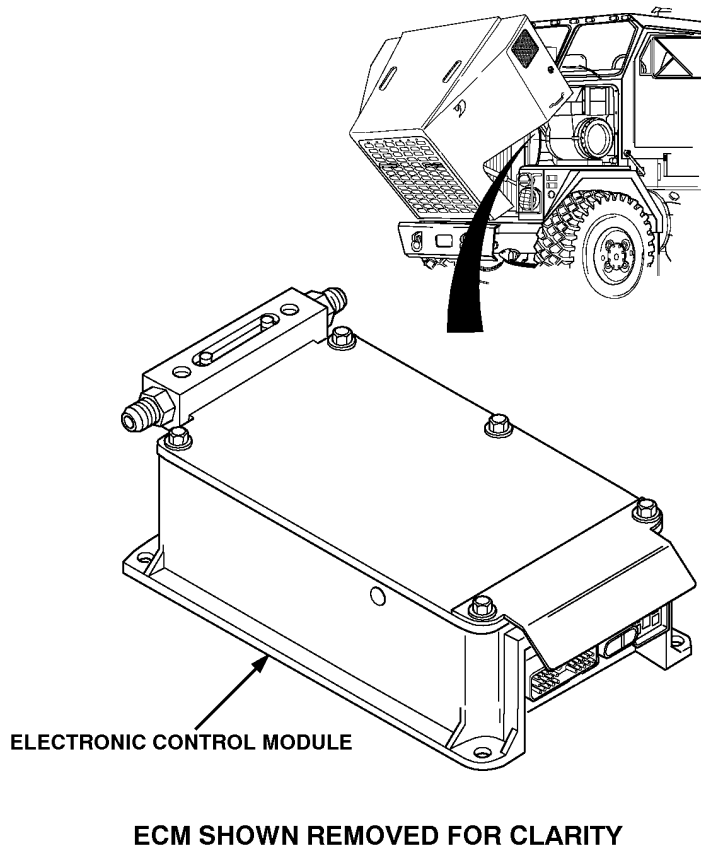
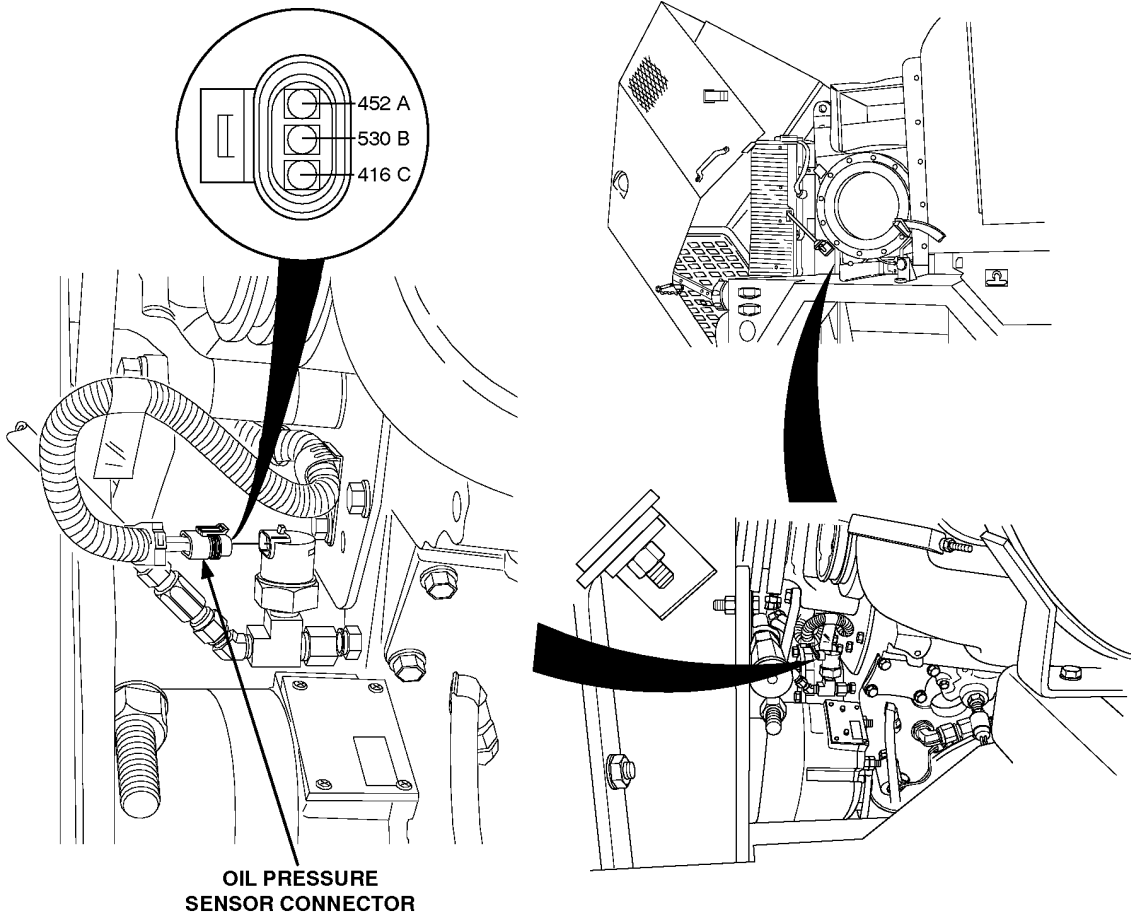

Section 4 TROUBLESHOOTING CHARTS

E. FLASH CODE: 45
J1587 CODE: P100 1 - OIL PRESSURE LOW

NOTE - This chart is only to be used if:

- 1) All basic mechanical checks and physical inspections have been performed with no problem found, and
- 2) Diagnosis of DDEC-III/IV was started at step START-10, pg H-25 and you have now been referred here.

STEP/SEQUENCE	RESULT	WHAT TO DO NEXT
45-1 Multiple Code Check		
<ul style="list-style-type: none"> • Were there any other codes besides 100/1? 	Yes. _____	→ Service other codes first.
	No. _____	→ This code indicates that there was an engine running condition at which oil pressure was lower than it should have been. Refer to Chapter 2, Vehicle Troubleshooting, to determine potential causes for low oil pressure.

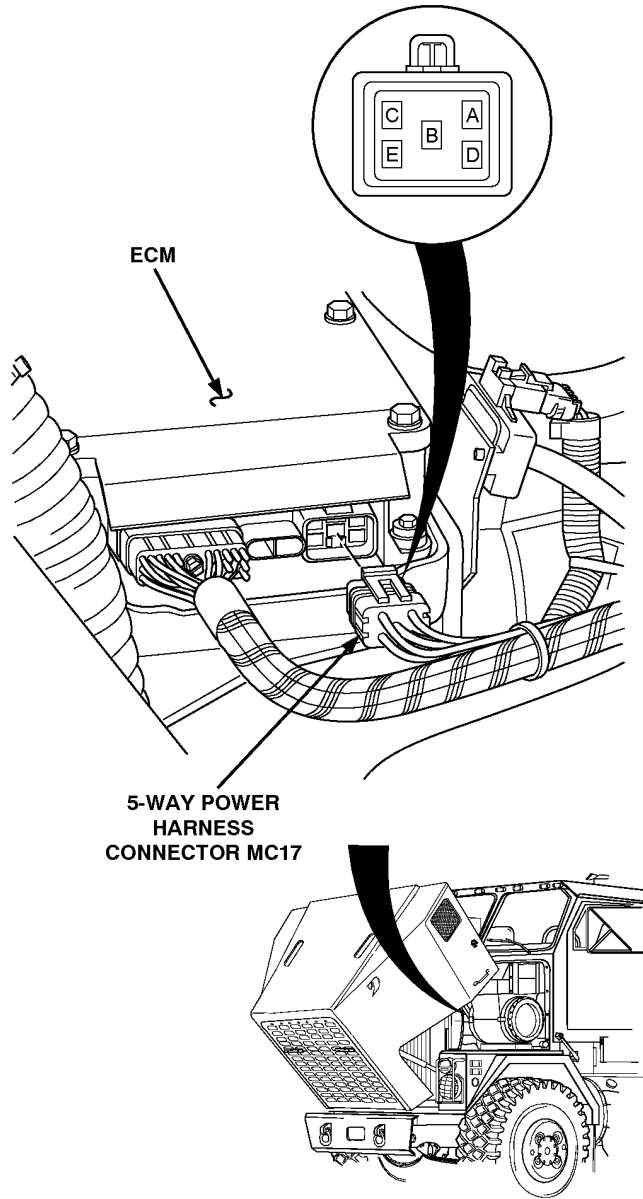

Section 4 TROUBLESHOOTING CHARTS

E. FLASH CODE: 46
J1587 CODE: P168 1 - BATTERY VOLTAGE LOW

NOTE - This chart is only to be used if:

- 1) All basic mechanical checks and physical inspections have been performed with no problem found, and
- 2) Diagnosis of DDEC-III/IV was started at step START-10, pg H-25 and you have now been referred here.

STEP/SEQUENCE	RESULT	WHAT TO DO NEXT
<p>46-2 Battery Check</p> <ul style="list-style-type: none"> • Start and run (TM 9-2320-360-10) engine for 1 minute. • Measure voltage on Battery + terminal (red lead) to Battery - terminal (black lead). 	<p>Engine does not start. →</p> <p>Less than or equal to 10.0 volts. →</p> <p>Greater than 10.0 volts. →</p>	<p>Determine cause for no-start.</p> <p>Start with an inspection of the battery (possibly discharged) and/or starting/charging system. Refer to Chart 2, page H-43, as a further aid in no-start diagnosis if battery and starting/charging system are okay.</p> <p>Service discharged battery (TM 9-6140-200-14) and/or starting/charging system.</p> <p>Go to 46-2.</p>
<p>46-2 Voltage Check at ECM</p> <ul style="list-style-type: none"> • Keep engine running. • Select ECM VOLTS on DDR for display. • Observe ECM voltage reading on DDR. 	<p>Less than or equal to 10.0 volts. →</p> <p>Greater than 10.0 volts. →</p>	<p>Go to 46-3.</p> <p>Go to 46-5.</p>
<p>46-3 Voltage Check at ECM</p> <ul style="list-style-type: none"> • Turn ignition off. • Disconnect 5-way power harness connector at the ECM. • Read voltage from socket A and C of 5-way power harness connector and a good battery ground (black lead). Don't use (ckt #150) as ground reference. 	<p>Less than or equal to 11.5 volts. →</p> <p>Greater than 11.5 volts. →</p>	<p>Go to 46-4.</p> <p>Go to 46-5.</p>

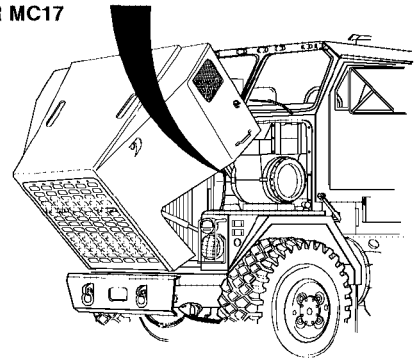
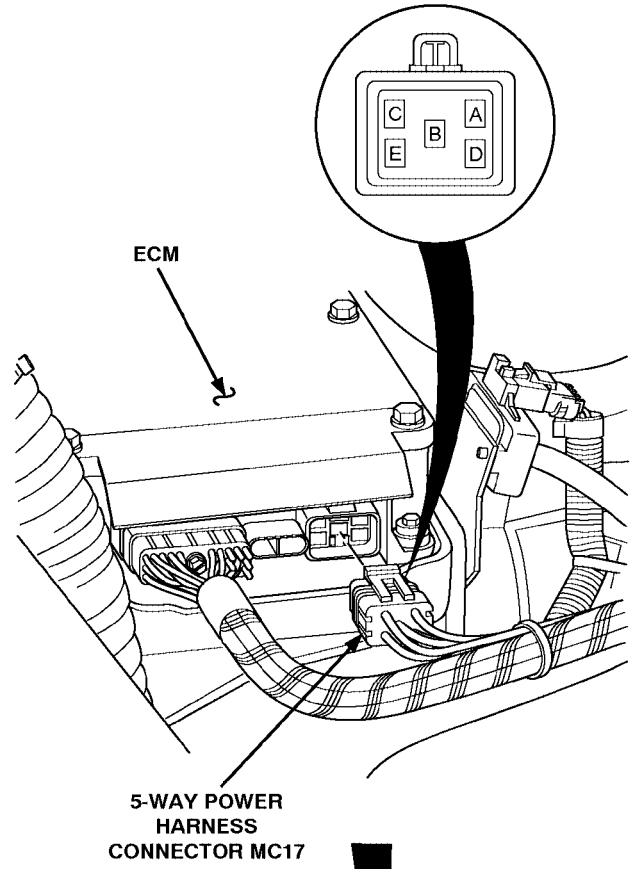
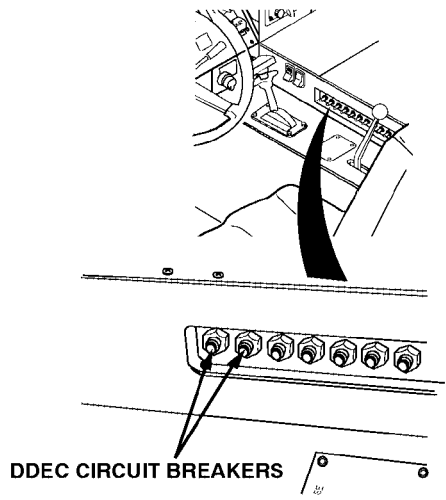

Section 4 TROUBLESHOOTING CHARTS

E. FLASH CODE: 46
J1587 CODE: P168 1 - BATTERY VOLTAGE LOW

STEP/SEQUENCE	RESULT	WHAT TO DO NEXT
<p>46-4 Check for Bad Battery + Line</p> <ul style="list-style-type: none"> • Deleted • Read voltage between battery side (hot side) of DDEC circuit breaker (red lead) and good ground (black lead). • Repeat voltage reading at other DDEC circuit breaker. 	<p>Less than or equal to 11.5 volts on either reading. →</p> <p>Greater than 11.5 volts on both readings. harness connector has a →</p>	<p>The Battery + line near Battery is open, or a corroded connection exists at Battery + terminal. Repair problem. Then go to 46-30.</p> <p>The Battery + line between the DDEC circuit breaker and ECM has an open, or 5-way power corroded connection. Repair problem. Then go to 46-30.</p>
<p>46-5 Ground Check at ECM</p> <ul style="list-style-type: none"> • Disconnect the 5-way power harness connector at ECM (if you have not previously done so). • Read voltage on socket C of 5-way power harness connector (red lead) to socket (black lead). • Also read voltage on socket A (red lead) to socket D (black lead). 	<p>Less than or equal to 11.5 volts on either reading. →</p> <p>Greater than 11.5 volts on both readings. →</p>	<p>The ground wire (ckt #150) is open or has a corroded connection. Repair ground wire. Then go to 46-30.</p> <p>Go to 46-6.</p>
<p>46-6 Check ECM Connectors</p> <ul style="list-style-type: none"> • Check terminals at 5-way power harness connector (both the ECM and harness side) for damage; bent, corroded, and unseated pins or sockets. 	<p>Terminals and connectors are okay. →</p> <p>Problem found. →</p>	<p>Replace ECM (para 7-29.1). Then go to 46-30.</p> <p>Repair terminals/connectors (para 7-77). Then go to 46-30.</p>

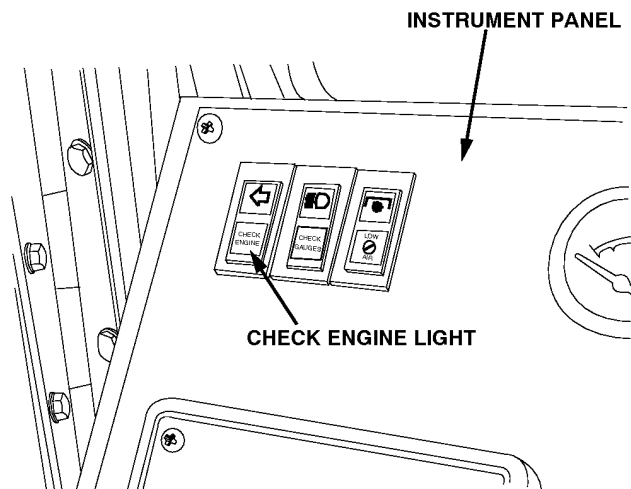

Section 4 TROUBLESHOOTING CHARTS

E. FLASH CODE: 46
 J1587 CODE: P168 1 - BATTERY VOLTAGE LOW

STEP/SEQUENCE	RESULT	WHAT TO DO NEXT
46-30 Verify Repairs		
<ul style="list-style-type: none"> • Turn ignition off. • Reconnect all connectors. • Turn ignition on. • Clear codes. • Note status of "Check Engine" light. • If "Check Engine" light does not stay on, start engine and run until (TM 9-2320-360-10) "Check Engine" light comes on or for 1 minute. • Stop engine. • Read inactive codes. 	No Codes. →	Repairs are complete.
	Code 168/1 (and any other codes). →	All system diagnostics are complete. Please review this section from start to find error.
	Any other codes except Code 168/1. →	Go to START-10, pg H-25, to service other codes.

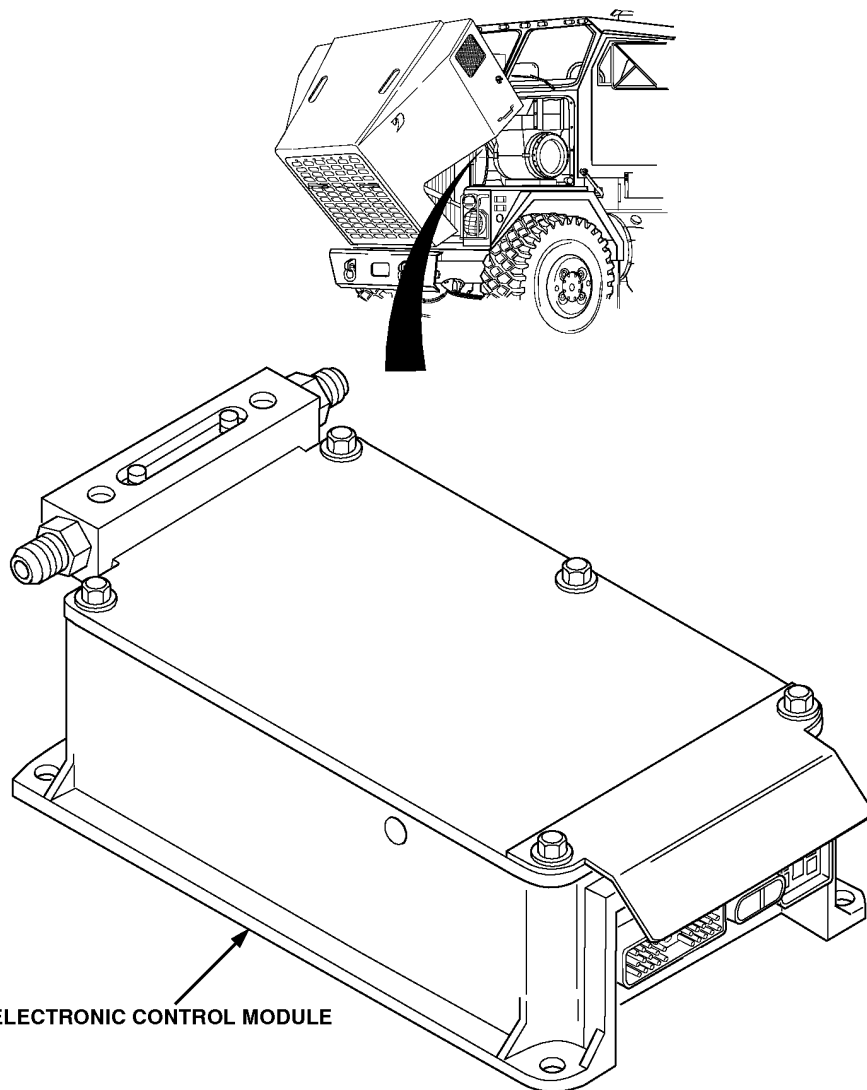

ELECTRONIC CONTROL MODULE

ECM SHOWN REMOVED FOR CLARITY

Section 4 TROUBLESHOOTING CHARTS

E. FLASH CODE: 52
J1587 CODE: S254 12 ANALOG TO DIGITAL (A/D) CONVERSION FAILURE

NOTE - This chart is only to be used if:

- 1) All basic mechanical checks and physical inspections have been performed with no problem found, and
- 2) Diagnosis of DDEC-III/IV was started at step START-10, pg H-25 and you have now been referred here.

STEP/SEQUENCE	RESULT	WHAT TO DO NEXT
52-1 Multiple Code Check		
<ul style="list-style-type: none"> • Were there any other codes besides 254/12? 	Yes. _____ → No. _____ →	Service other codes first. Replace ECM (para 7-29.1). Then go to START-10, pg H-25.

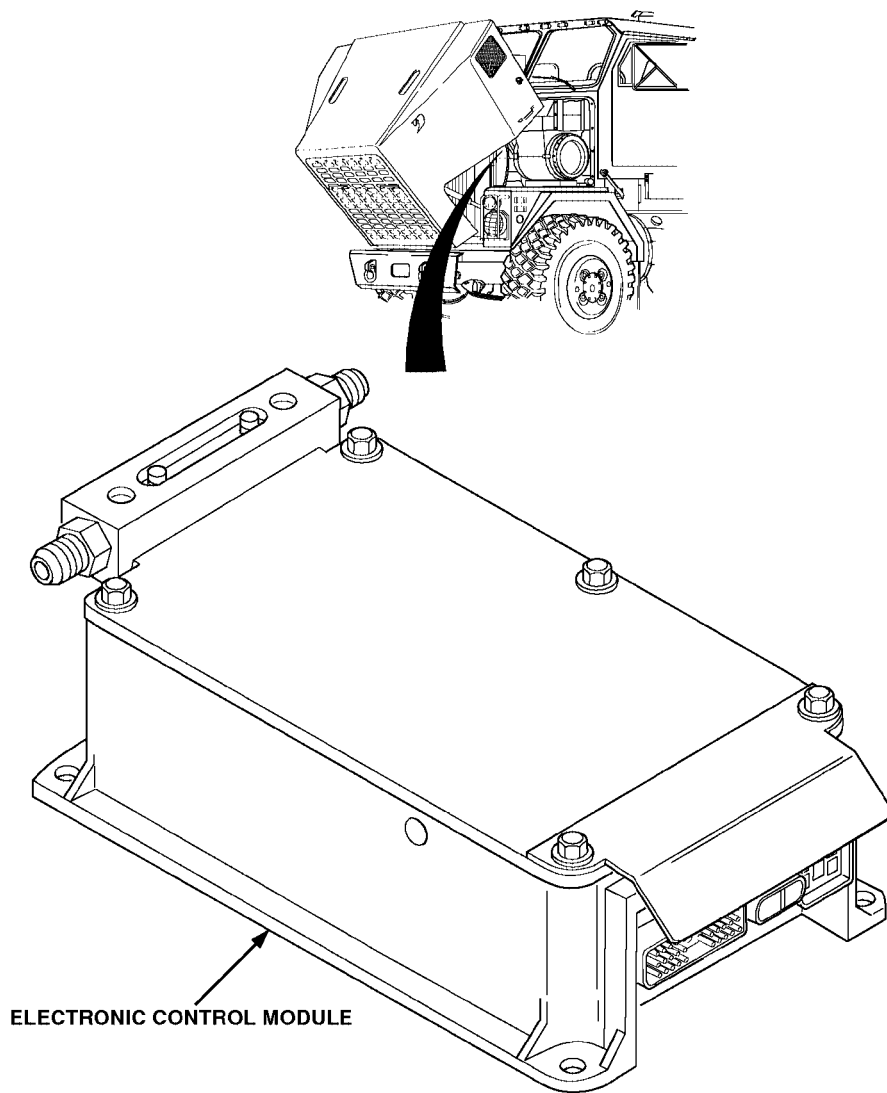

ELECTRONIC CONTROL MODULE

ECM SHOWN REMOVED FOR CLARITY

**Section 4
TROUBLESHOOTING CHARTS**

E. FLASH CODE: 53
J1587 CODE: S253 12 NONVOLATILE MEMORY FAILURE

NOTE - This chart is only to be used if:

- 1) All basic mechanical checks and physical inspections have been performed with no problem found, and
- 2) Diagnosis of DDEC-III/IV was started at step START-10, pg H-25 and you have now been referred here.

STEP/SEQUENCE	RESULT	WHAT TO DO NEXT
<p>53-1 Replace ECM</p>		<p>Replace ECM (para 7-29.1).</p>
<ul style="list-style-type: none"> • An error has been detected in EEPROM in the ECM which will cause it to not log codes correctly or at all. 		

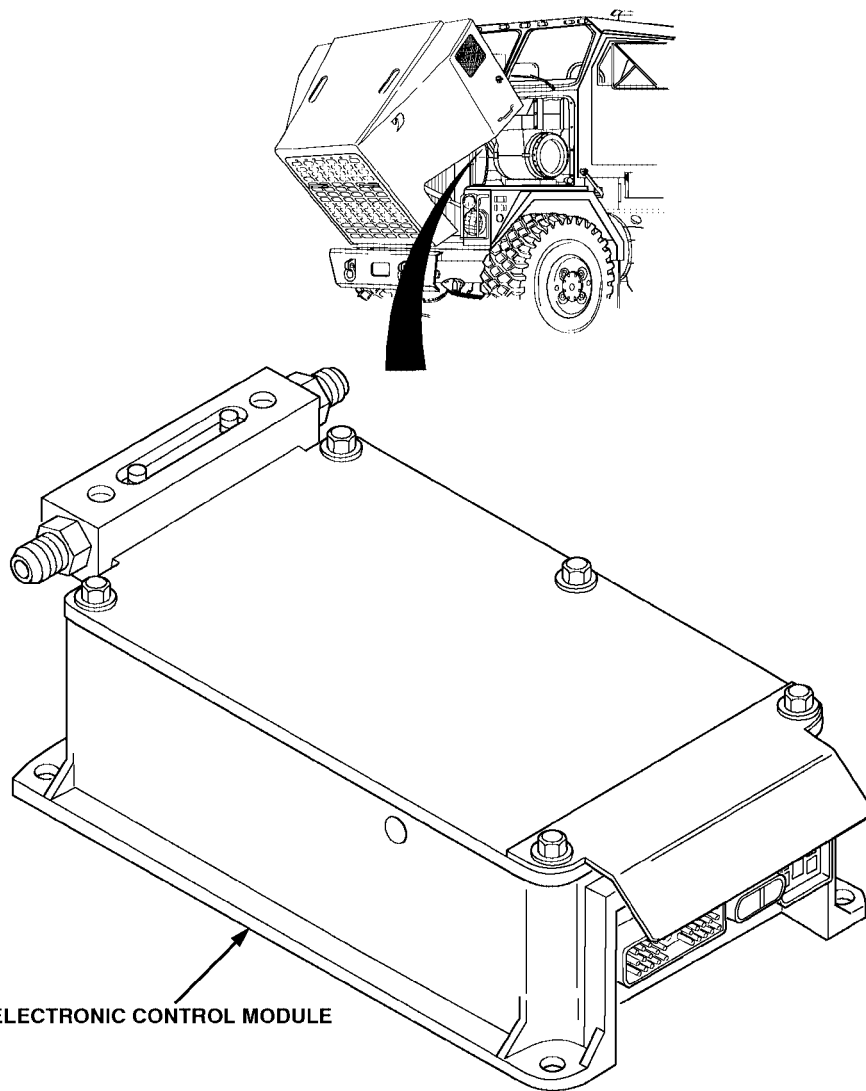

ELECTRONIC CONTROL MODULE

ECM SHOWN REMOVED FOR CLARITY

Section 4 TROUBLESHOOTING CHARTS

E. FLASH CODE: 56
J1587 CODE: S250 12 - J1587 DATA LINK FAULT

NOTE - This chart is only to be used if:

- 1) All basic mechanical checks and physical inspections have been performed with no problem found, and
- 2) Diagnosis of DDEC-III/IV was started at step START-10, pg H-25 and you have now been referred here.

STEP/SEQUENCE	RESULT	WHAT TO DO NEXT
<p>56-1 Check for Codes</p> <hr/> <ul style="list-style-type: none"> • Plug in DDR. • Turn ignition on. • Read codes. 	<p>No Data Received. →</p> <p>Code 250/12 only. →</p> <p>Any other codes present? →</p>	<p>Go to C 7-8.</p> <p>Go to 56-2.</p> <p>Service other codes first.</p>
<p>56-2 Clear Codes</p> <hr/> <ul style="list-style-type: none"> • Clear codes. • Start and run engine (TM 9-2320-360-10) observe CEL code. 	<p>CEL on w/code 250/12. →</p> <p>No CEL code. →</p>	<p>Replace ECM (para 7-29.1). Then go to 56-30.</p> <p>Go to 56-30.</p>
<p>56-30 Verify Repairs</p> <hr/> <ul style="list-style-type: none"> • Turn ignition off. • Turn ignition on and observe "Check Engine" light. 	<p>"Check Engine" light comes on for 5 seconds and goes out. →</p> <p>"Check Engine" light comes on and stays on. →</p>	<p>Repairs are complete.</p> <p>All system diagnostics are complete. Please review this section to find the error.</p>

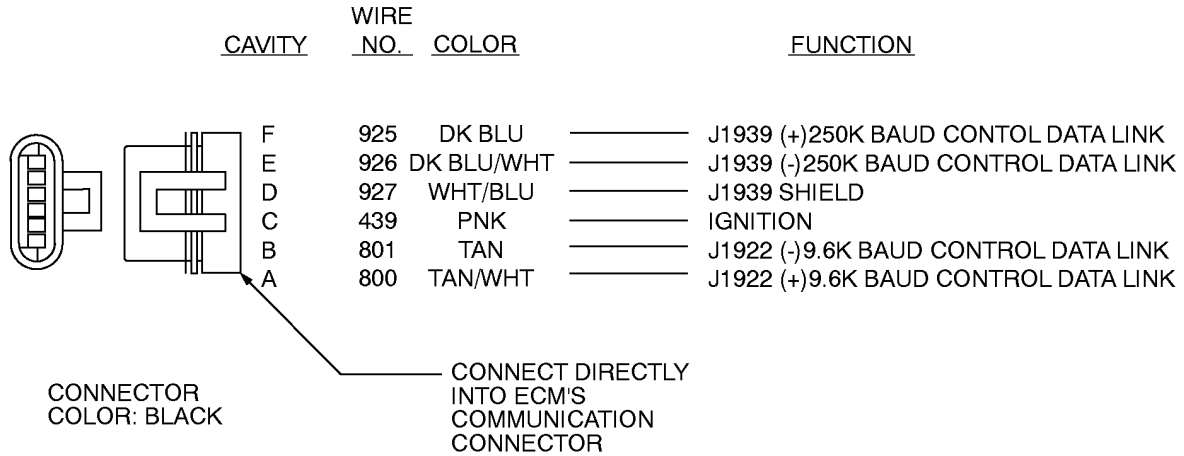

**COMMUNICATION HARNESS
(NOT CURRENTLY ON HET M1070)**

Section 4 TROUBLESHOOTING CHARTS

E. FLASH CODE: 57
J1587 CODE: S249 12 - J 1922 DATA LINK FAULT

NOTE - This chart is only to be used if:

- 1) All basic mechanical checks and physical inspections have been performed with no problem found, and
- 2) Diagnosis of DDEC-III/IV was started at step START-10, pg H-25 and you have now been referred here.

STEP/SEQUENCE	RESULT	WHAT TO DO NEXT
<p>57-1 Multiple code check</p> <ul style="list-style-type: none"> • Were there any codes beside 249/12? 	<p>Yes. —————→</p> <p>No. —————→</p>	<p>Service other codes first.</p> <p>Go to 57-2.</p>
<p>57-2 Check for open</p> <ul style="list-style-type: none"> • Turn ignition off. • Unplug the 6-pin communications connector. • Place a jumper wire across pins A (#800) and B (#801) • Locate other ends of wire #800 and #801. Measure resistance between wires. 	<p>Greater than 5 ohms. —————→</p> <p>Less than 5 ohms. —————→</p>	<p>One or both data lines are open. Repair open. Go to 57-30.</p> <p>Go to 57-3.</p>
<p>57-3 Check for short</p> <ul style="list-style-type: none"> • Remove jumper wire. • Read resistance between pin A (#800) and B (#801) of the communications connector. 	<p>Less than 5 ohms. —————→</p> <p>Greater than 5 ohms. —————→</p>	<p>The two data wires are shorted together repair short and go to 57-30.</p> <p>Replace ECM (7-29.1). Then go to 57-30.</p>
<p>57-30 Verify repairs</p> <ul style="list-style-type: none"> • Turn ignition off. • Reconnect all connections. • Turn ignition on. • Clear codes. • Start and run engine (TM 9-2320-360-10) for 1 minute. • Note status of "Check Engine" light. • Check for codes. 	<p>No codes. —————→</p> <p>Codes appears. —————→</p>	<p>Repairs are complete.</p> <p>Go to START-1, pg H-25. All diagnostics are complete. Review to find the error.</p>

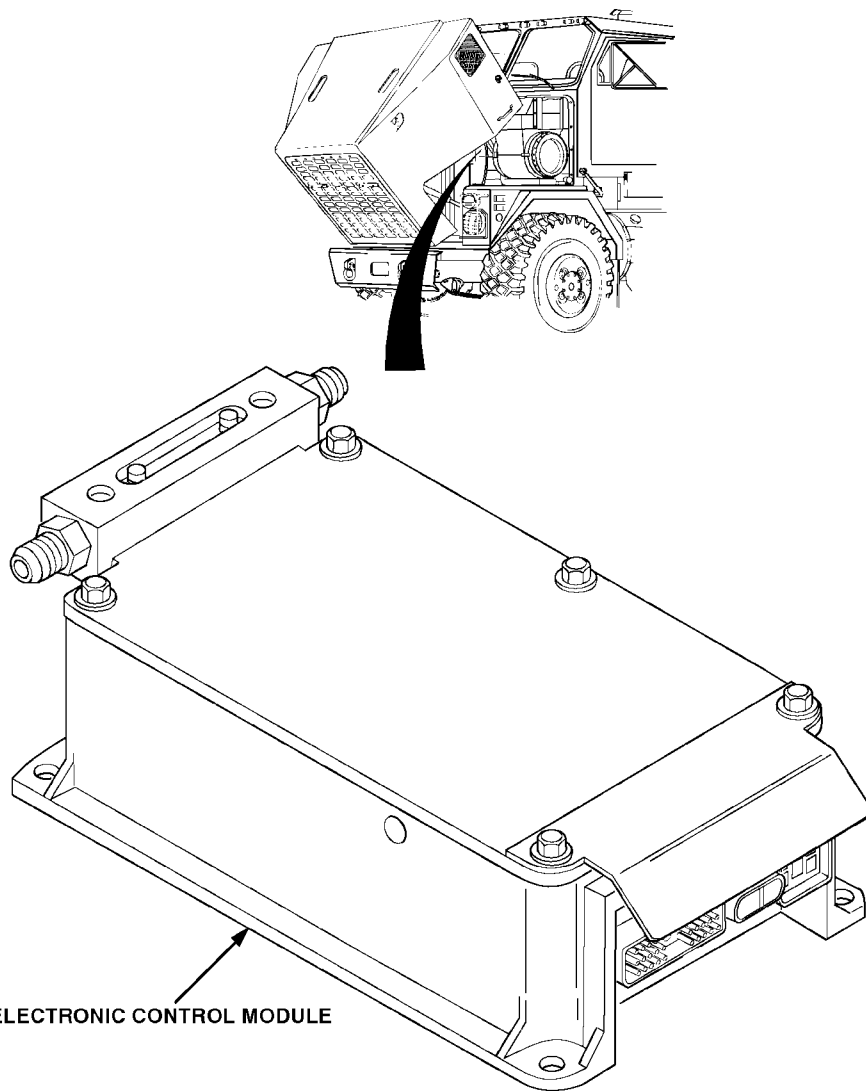

ELECTRONIC CONTROL MODULE

ECM SHOWN REMOVED FOR CLARITY

Section 4
TROUBLESHOOTING CHARTS

E. FLASH CODE: 62
**J1587 CODE: S026 3/4 - AUXILIARY OUTPUT SHORT TO BATTERY,
AUXILIARY OUTPUT OPEN CIRCUIT**

NOTE - This chart is only to be used if:

- 1) All basic mechanical checks and physical inspections have been performed with no problem found, and
- 2) Diagnosis of DDEC-III/IV was started at step START-10, pg H-25 and you have now been referred here.

STEP/SEQUENCE		
62-1 Determine SAE Codes		
<ul style="list-style-type: none"> • 26-3 • 26-4 	Auxiliary ouput Auxiliary ouput	#1 short to battery (ckt 988). #1 open circuit (ckt 988).

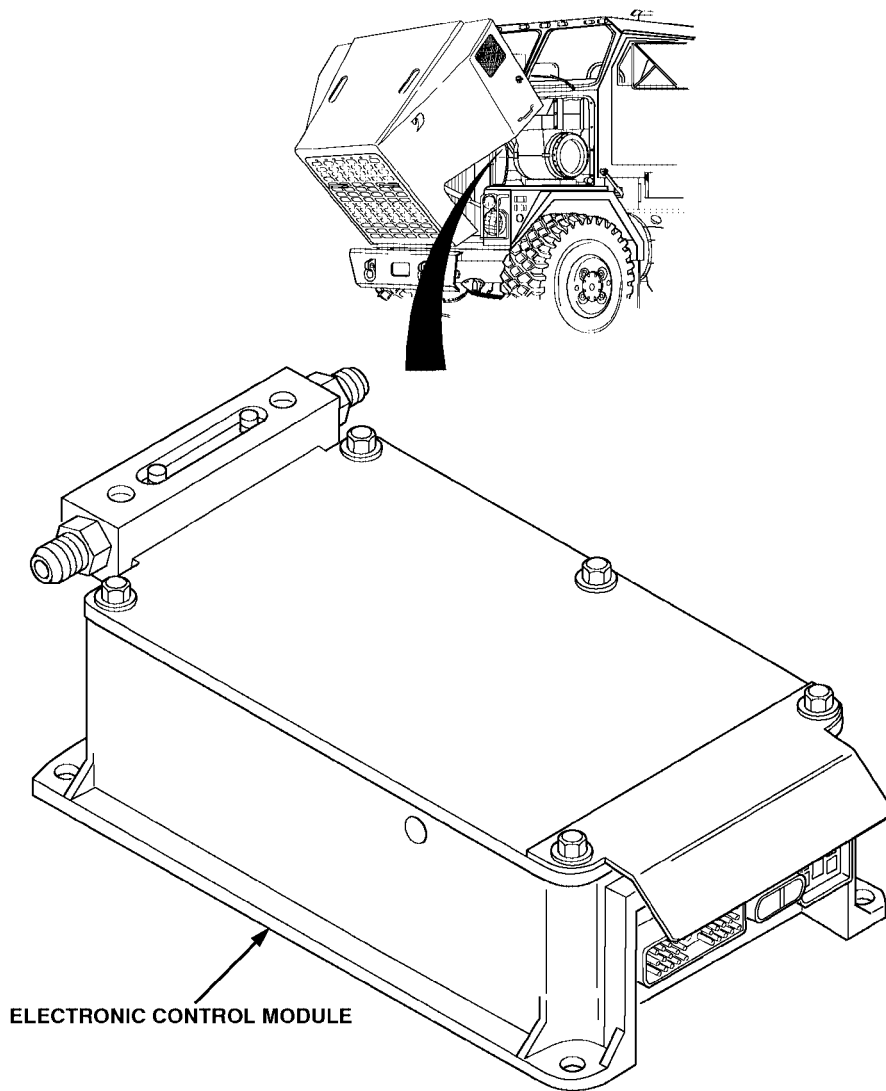

ELECTRONIC CONTROL MODULE

ECM SHOWN REMOVED FOR CLARITY

Section 4 TROUBLESHOOTING CHARTS

E. FLASH CODE: 63
J1587 CODE: S057 3/4 - PWM SHORT TO BATTERY/PWM OPEN CIRCUIT

NOTE - This chart is only to be used if:

- 1) All basic mechanical checks and physical inspections have been performed with no problem found, and
- 2) Diagnosis of DDEC-III/IV was started at step START-10, pg H-25 and you have now been referred here.

STEP/SEQUENCE					
63 Determine SAE Codes					
<ul style="list-style-type: none"> • 57-3 • 57-4 	<table style="width: 100%; border: none;"> <tr> <td style="width: 30%; border: none;">PWM #1</td> <td style="border: none;">Short to battery (ckt 908).</td> </tr> <tr> <td style="border: none;">PWM #1</td> <td style="border: none;">Open circuit (ckt 908).</td> </tr> </table>	PWM #1	Short to battery (ckt 908).	PWM #1	Open circuit (ckt 908).
PWM #1	Short to battery (ckt 908).				
PWM #1	Open circuit (ckt 908).				

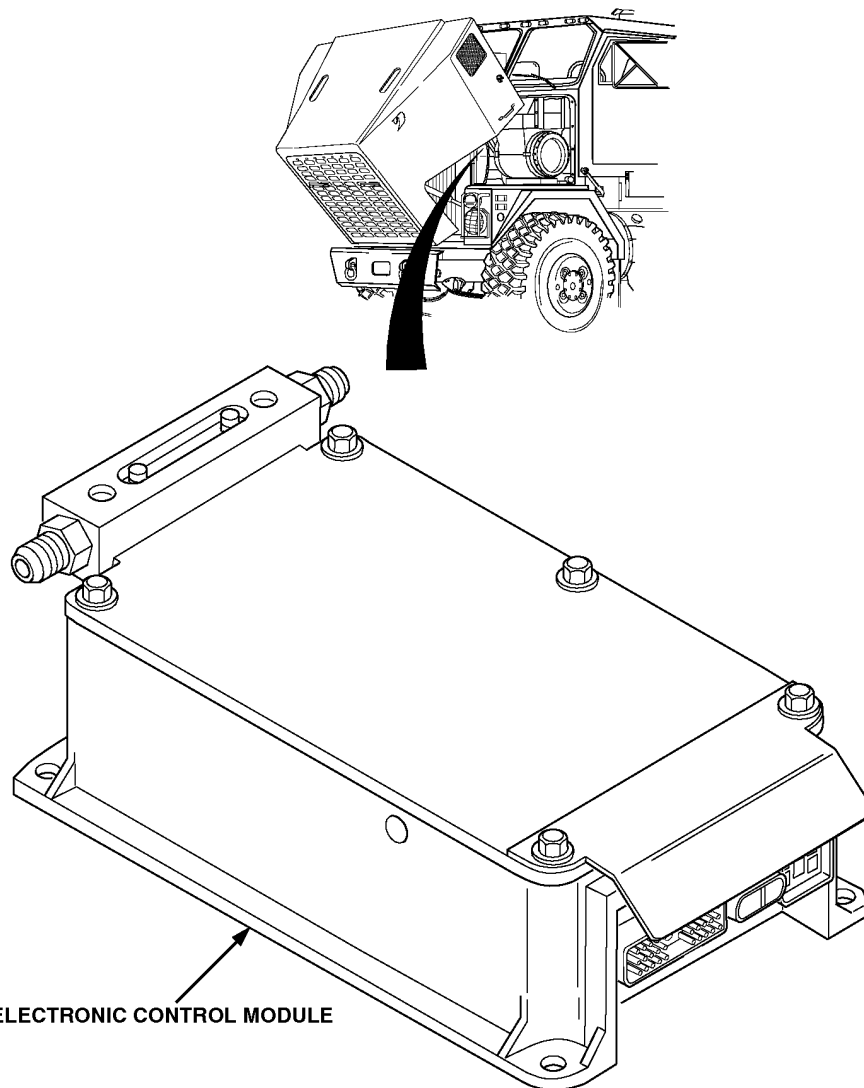

ELECTRONIC CONTROL MODULE

ECM SHOWN REMOVED FOR CLARITY

Section 4 TROUBLESHOOTING CHARTS

E. FLASH CODE: 75
J1587 CODE: P168 0 - BATTERY VOLTAGE HIGH

NOTE - This chart is only to be used if:

- 1) All basic mechanical checks and physical inspections have been performed with no problem found, and
- 2) Diagnosis of DDEC-III/IV was started at step START-10, pg H-25 and you have now been referred here.

STEP/SEQUENCE	RESULT	WHAT TO DO NEXT
75-1 High Voltage		
<ul style="list-style-type: none"> • Turn ignition on. • Plug in DDR. • Read codes. 	<p>Any code(s) other 168/0. →</p> <p>Code 168/0. →</p>	<p>Service other codes first.</p> <p>Code 168/0 indicates too high a voltage to the ECM. Check batteries and/or vehicle charging system.</p>

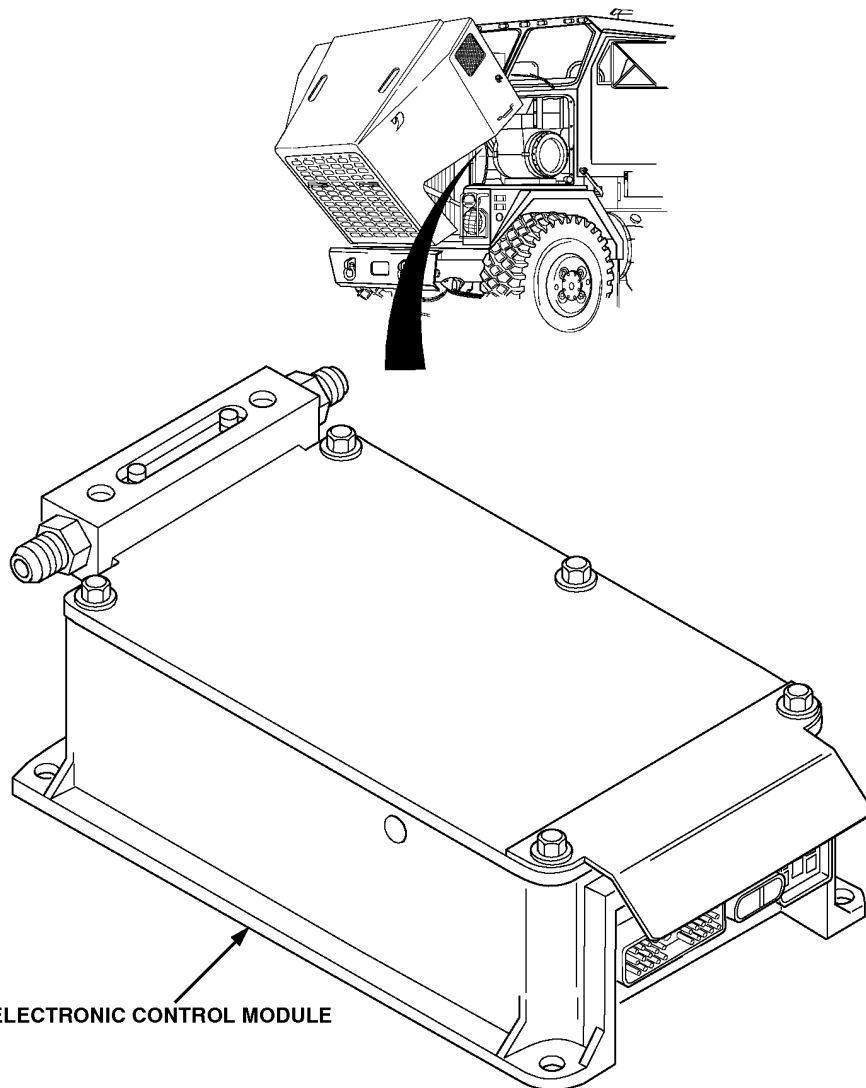

ELECTRONIC CONTROL MODULE

ECM SHOWN REMOVED FOR CLARITY

Section 4 TROUBLESHOOTING CHARTS

E. FLASH CODE: 76
J1587 CODE: P121 0 - ENGINE OVERSPEED WITH ENGINE BRAKE

NOTE - This chart is only to be used if:

- 1) All basic mechanical checks and physical inspections have been performed with no problem found, and
- 2) Diagnosis of DDEC-III/IV was started at step START-10, pg H-25 and you have now been referred here.

76-2 Code Information	
------------------------------	--

This code is for information purposes only. It is logged whenever the engine has been operating over 2500 rpm for at least 2 seconds with engine brake operation. To get complete information, do the following.

- Turn ignition on.
- Plug in DDR.
- Select inactive codes.
- At least part of the display will look like the following example:

First Occurrence

Last Occurrence

Total Number

Total Time

(For some) Min/Max Value that caused the code to be logged.

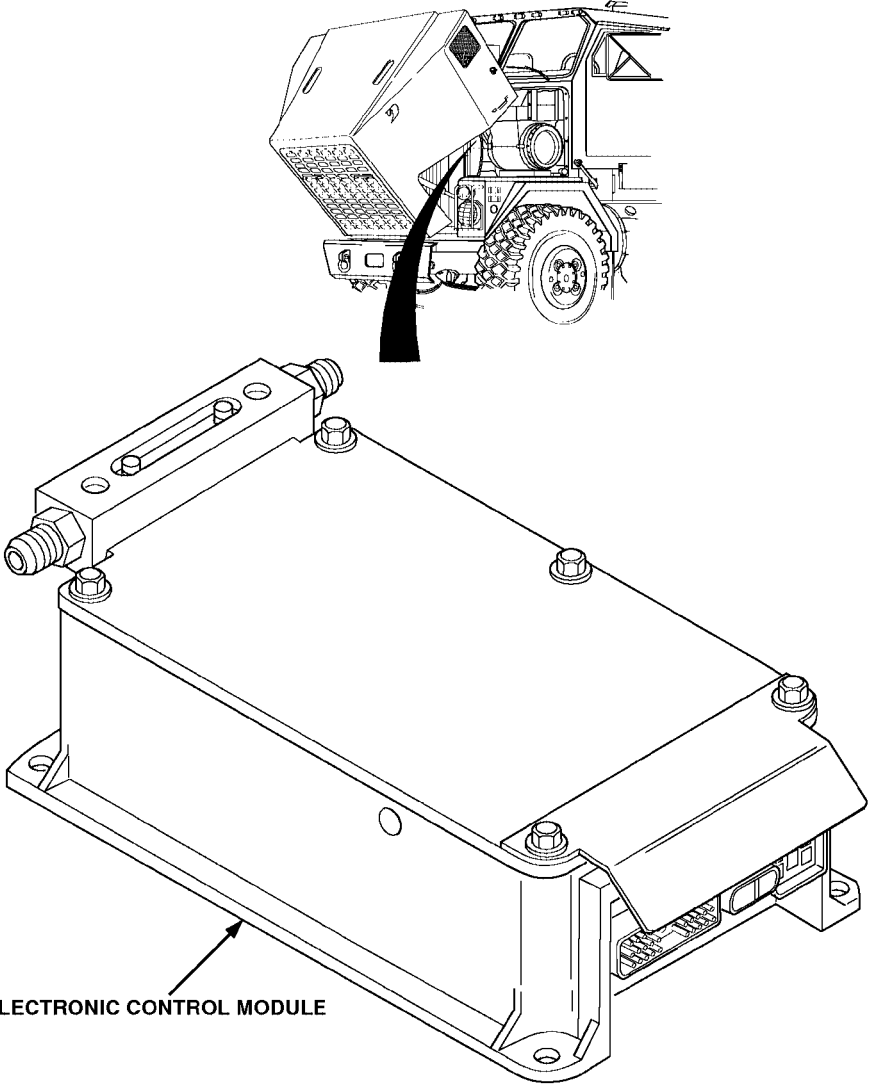

ELECTRONIC CONTROL MODULE

ECM SHOWN REMOVED FOR CLARITY

Section 4 TROUBLESHOOTING CHARTS

E. FLASH CODE: 85
J1587 CODE: P190 0 - ENGINE OVERSPEED

NOTE - This chart is only to be used if:

- 1) All basic mechanical checks and physical inspections have been performed with no problem found, and
- 2) Diagnosis of DDEC-III/IV was started at step START-10, pg H-25 and you have now been referred here.

85-2 Code Information	
------------------------------	--

This code is for information purposes only. It is logged whenever the engine has been operating over 2500 rpm for at least 2 seconds. To get complete information, do the following.

- Turn ignition on.
- Plug in DDR.
- Select inactive codes.
- At least part of the display will look like the following example:

First Occurrence

Last Occurrence

Total Number

Total Time

(For some) Min/Max Value that caused the code to be logged.

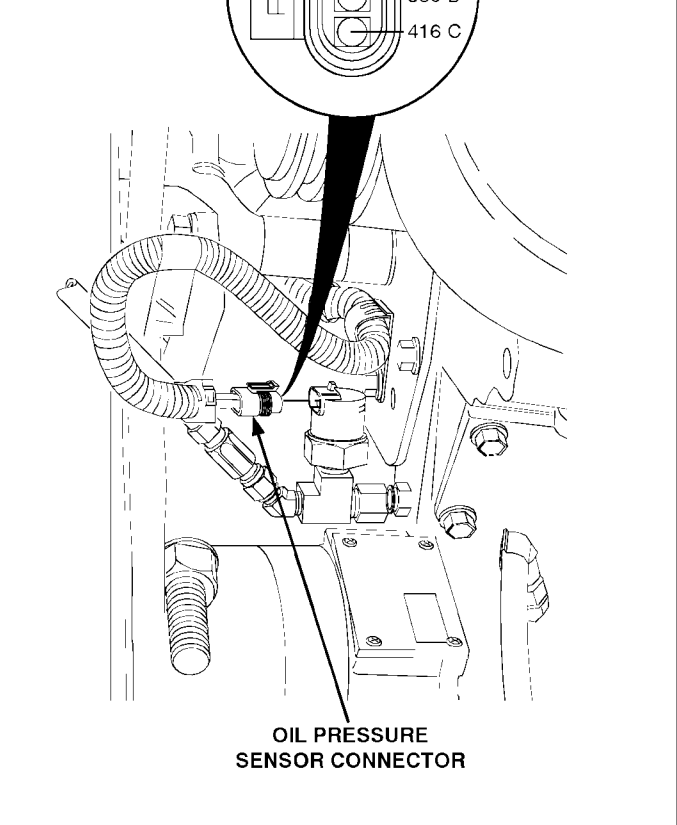
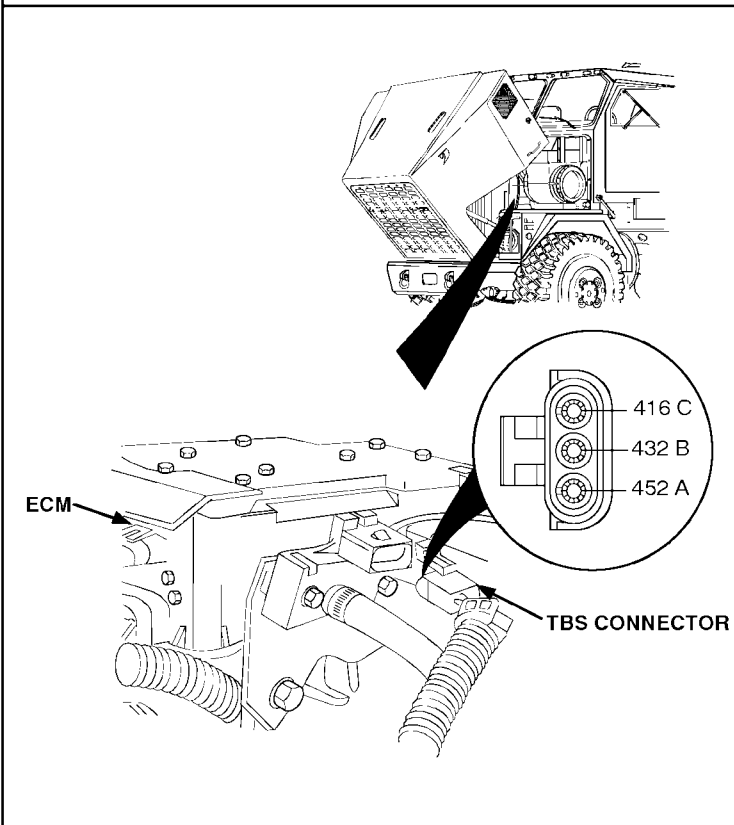
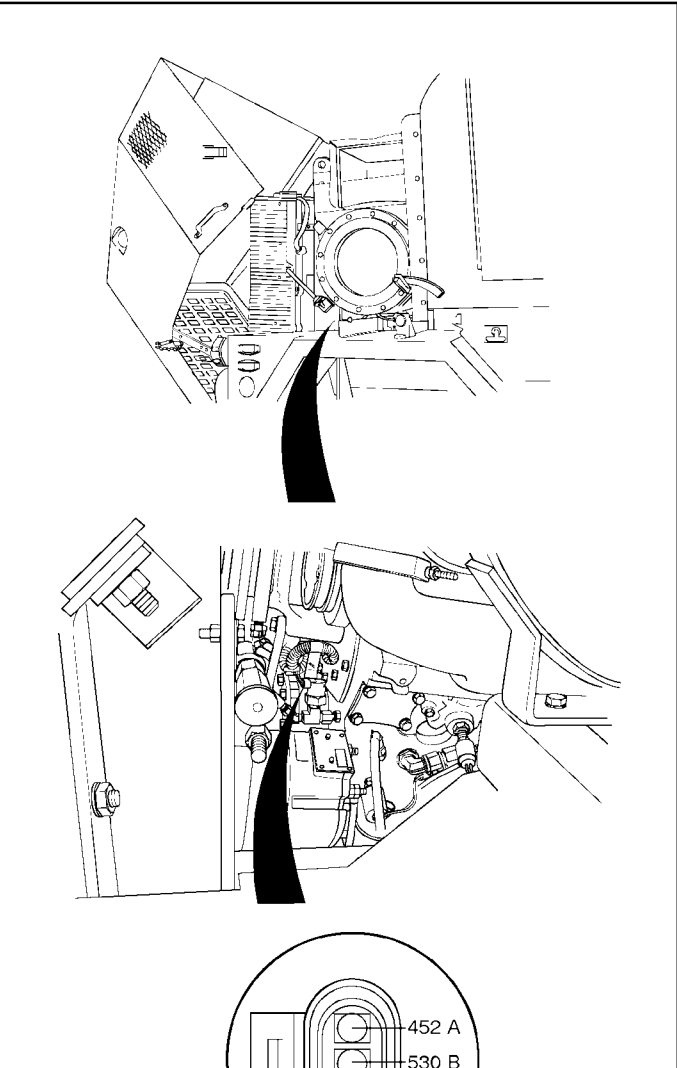
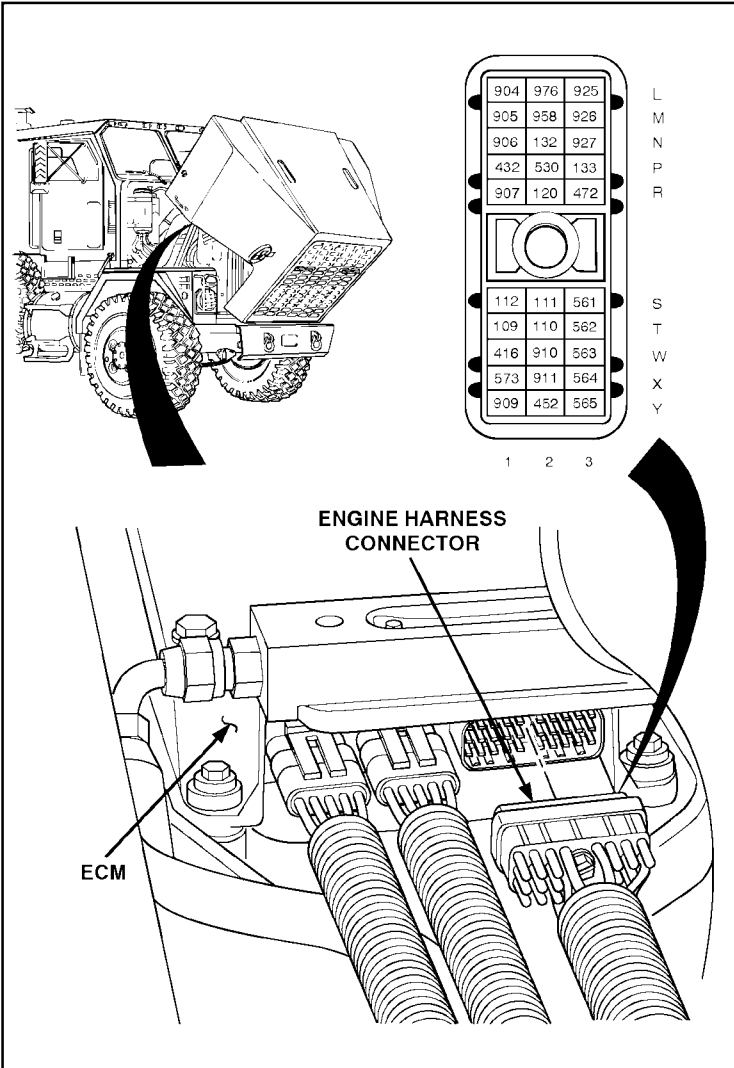

Section 4 TROUBLESHOOTING CHARTS

E. ENG5V - ENGINE HARNESS +5 VOLTS SUPPLY

NOTE - This chart is only to be used if:

- 1) All basic mechanical checks and physical inspections have been performed with no problem found, and
- 2) Diagnosis of DDEC-III/IV was started at step START-10, pg H-25 and you have now been referred here.

STEP/SEQUENCE	RESULT	WHAT TO DO NEXT
ENG5V-2 Check for Low Battery Voltage		
<ul style="list-style-type: none"> • Was there also a Code 168/1? 	<p>Yes. </p> <p>No. </p>	<p>Go to 46-2 (page H-217).</p> <p>Go to ENG5V-2.</p>
ENG5V-2 Check for + 5 Volts		
<ul style="list-style-type: none"> • Turn ignition off. • Disconnect the Oil Pressure Sensor (OPS) and Turbo Boost Sensor (TBS) connectors. • Turn ignition on. <p>At each sensors harness connector, read voltage between socket C (red lead) and sockets A (black lead).</p>	<p>Between 4.7 and 5.2 volts.</p> <p>Less than 4.7 volts at any or all connectors.</p> <p>Greater than 5.2 volts at all connectors.</p>	<p>Voltage reading is correct. Check voltage at next connector. If all connector voltage readings are correct, go to ENG5V-3.</p> <p>Go to ENG5V-4.</p> <p>Go to ENG5V-6.</p>
ENG5V-3 Check ECM Connectors		
<ul style="list-style-type: none"> • Check terminals at the engine harness connector (both the ECM and harness side) for damaged, bent, corroded and unseated pins or sockets. 	<p>Terminals and connectors are okay.</p> <p>Problems found. </p>	<p>Replace ECM (para 7-29.1). Then go to ENG5V-30.</p> <p>Repair terminals/connectors (para 7-77. Then go to ENG5V-30.</p>

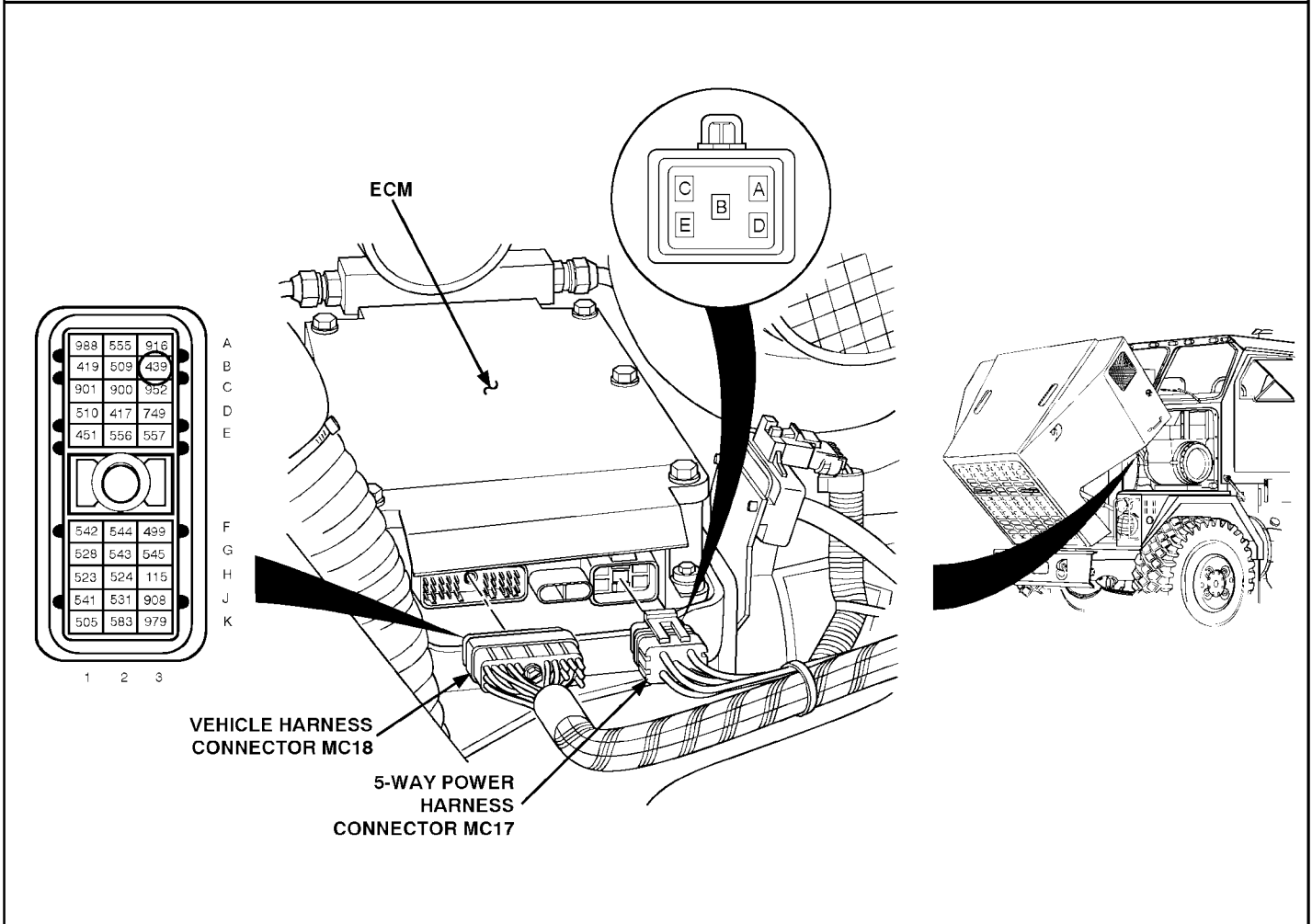
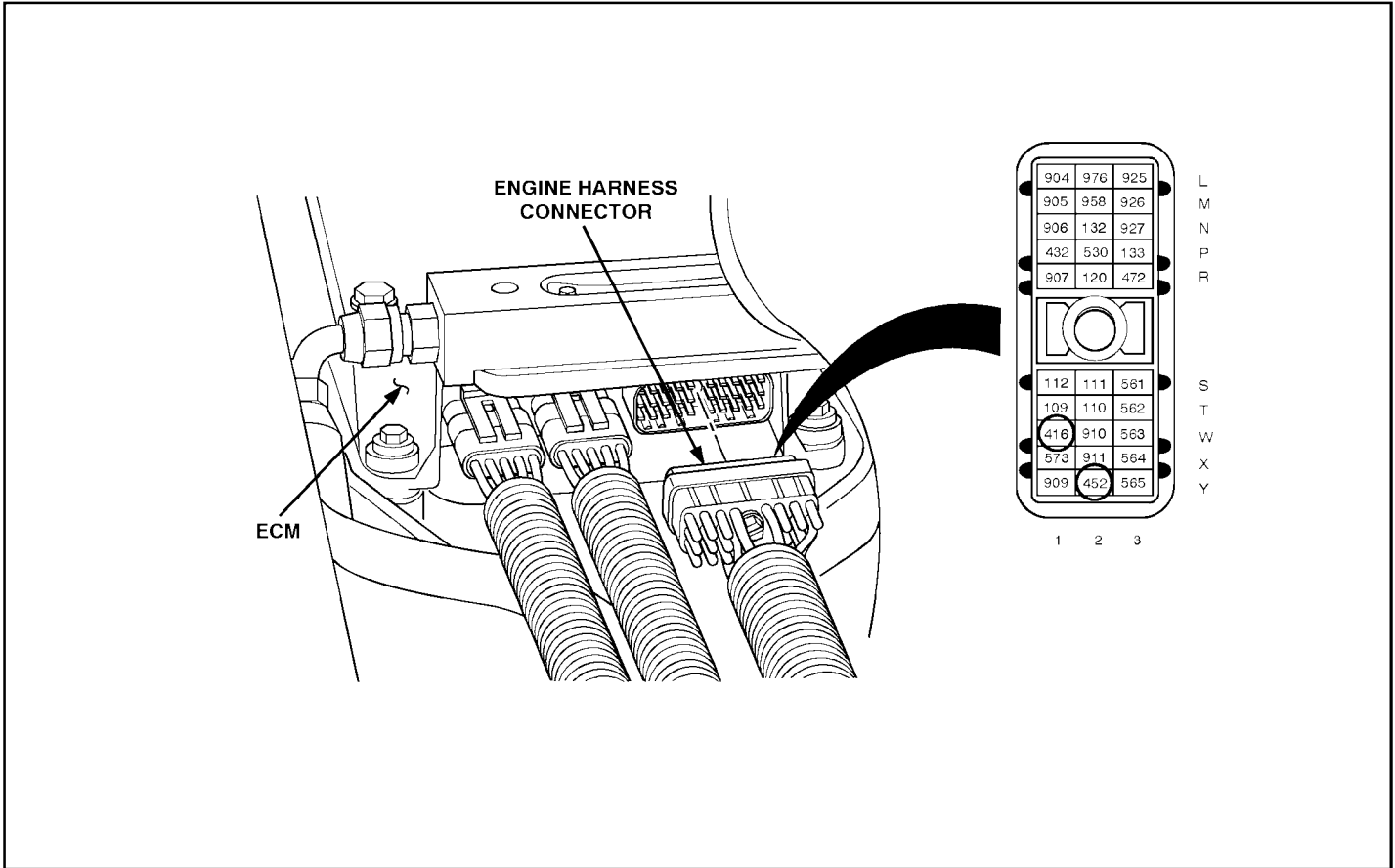

Section 4 TROUBLESHOOTING CHARTS

E. ENG5V - ENGINE HARNESS +5 VOLTS SUPPLY (CONT'D)

STEP/SEQUENCE	RESULT	WHAT TO DO NEXT
ENG5V-4 Check for +5 Volts or Return Open		
<ul style="list-style-type: none"> • Turn ignition off. • Disconnect the engine harness connector at the ECM. • Install a jumper wire between sockets A and C of any sensor connector that reads less than 4.7 volts in Step ENG5V-2. • Read resistance between sockets W1 and Y2 of the engine harness connector. 	<p>Less than or equal to 5 ohms. → Go to ENG5V-5.</p> <p>Greater than 5 ohms or open. → Either the engine +5 volt line (ckt #416) or the sensor return line (ckt #452) is open. Repair open. Then go to ENG5V-30.</p>	
ENG5V-5 Check for Short to Ground		
<ul style="list-style-type: none"> • Turn ignition off. • Remove jumper wire. • Read resistance between sockets A and C of the sensor connector. • Also read resistance between socket C of the sensor connector and a good ground. 	<p>Both readings are greater than 10,000 ohms or open. → Go to ENG5V-3.</p> <p>Either reading is less than or equal to 10,000 ohms. → The engine +5 volt line (ckt #416) is shorted to either the sensor return line (ckt #452) or to chassis ground. Repair short. Then go to ENG5V-30.</p>	
ENG5V-6 Check for Short to Battery +		
<ul style="list-style-type: none"> • Turn ignition off. • Disconnect batteries (para 7-61). • Disconnect all six connectors at the ECM. • Read resistance between socket W1 on the engine harness connector and B3 on the vehicle harness connector. • Also read resistance between socket W1 on the engine harness connector and the following sockets on the 5-way power harness connector: A and C. 	<p>All readings are greater than 10,000 ohms or open. → Go to ENG5V-3.</p> <p>Any reading is less than or equal to 10,000 ohms. → A short exists between sockets where less than 10,000 ohms resistance was read. Repair short. Then go to ENG5V-30.</p>	

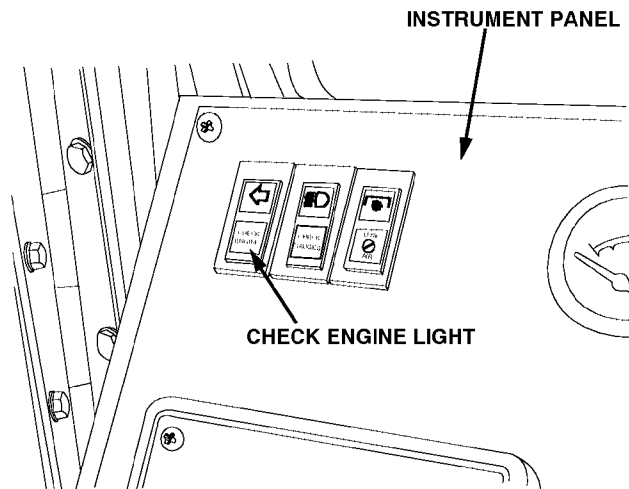

Section 4 TROUBLESHOOTING CHARTS

E. ENG5V - ENGINE HARNESS +5 VOLTS SUPPLY (CONT'D)

STEP/SEQUENCE	RESULT	WHAT TO DO NEXT
<p>ENG5V-30 Verify Repairs</p> <ul style="list-style-type: none"> • Turn ignition off. • Reconnect all connectors. • Turn ignition on. • Clear codes. • If "Check Engine" light does not stay on, start engine and run (TM 9-2320-360-10) for 1 minute or until "Check Engine" light comes on. • Stop engine. • Read inactive codes. 	<p>No codes. </p> <p>Codes which brought you to Chart ENG5V are still there. </p> <p>Any codes except those which brought you to Chart ENG5V. </p>	<p>Repairs are complete.</p> <p>Go to VEH5V, page H-247.</p> <p>Go to START-10, pg H-25, to service other codes.</p>

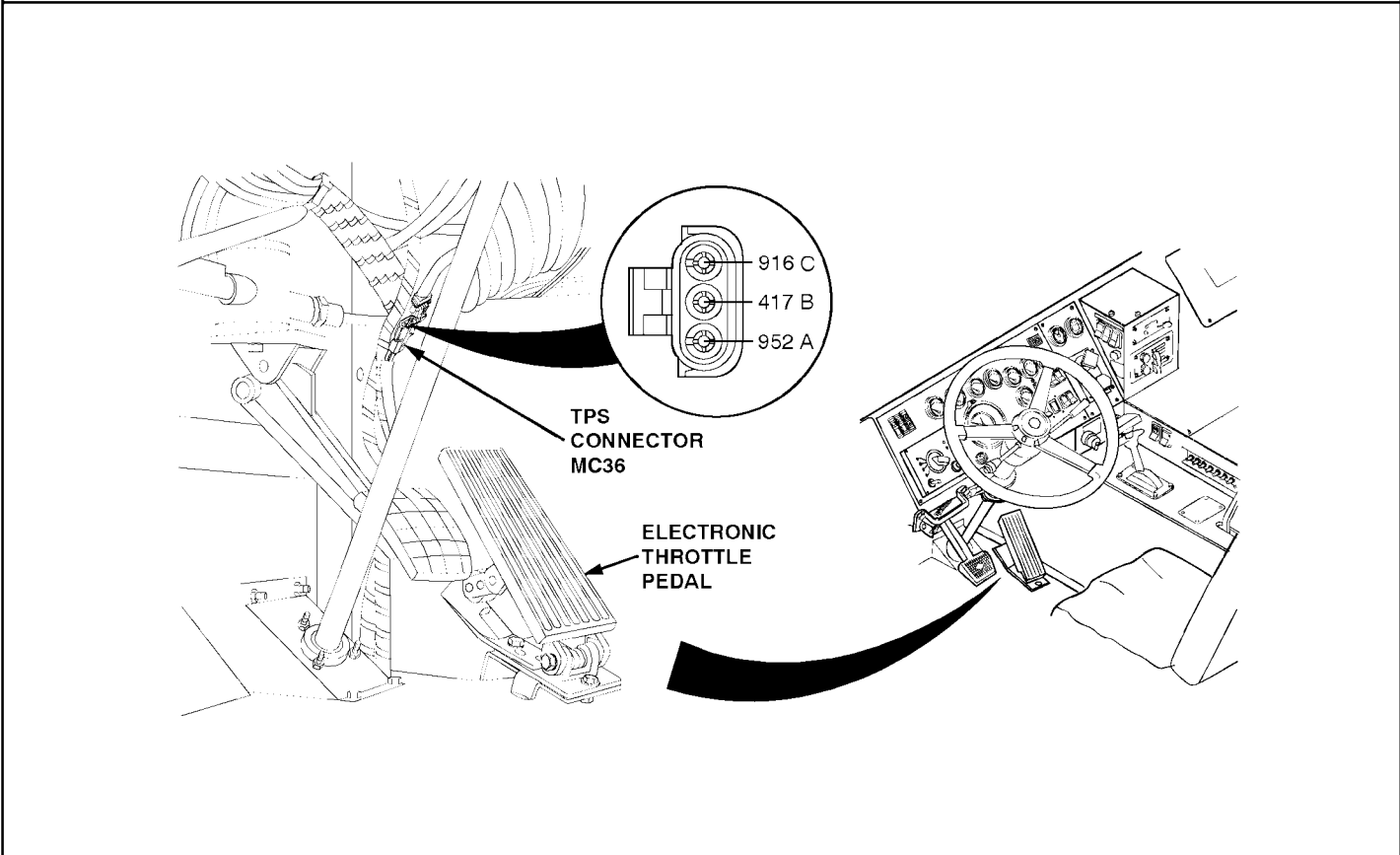
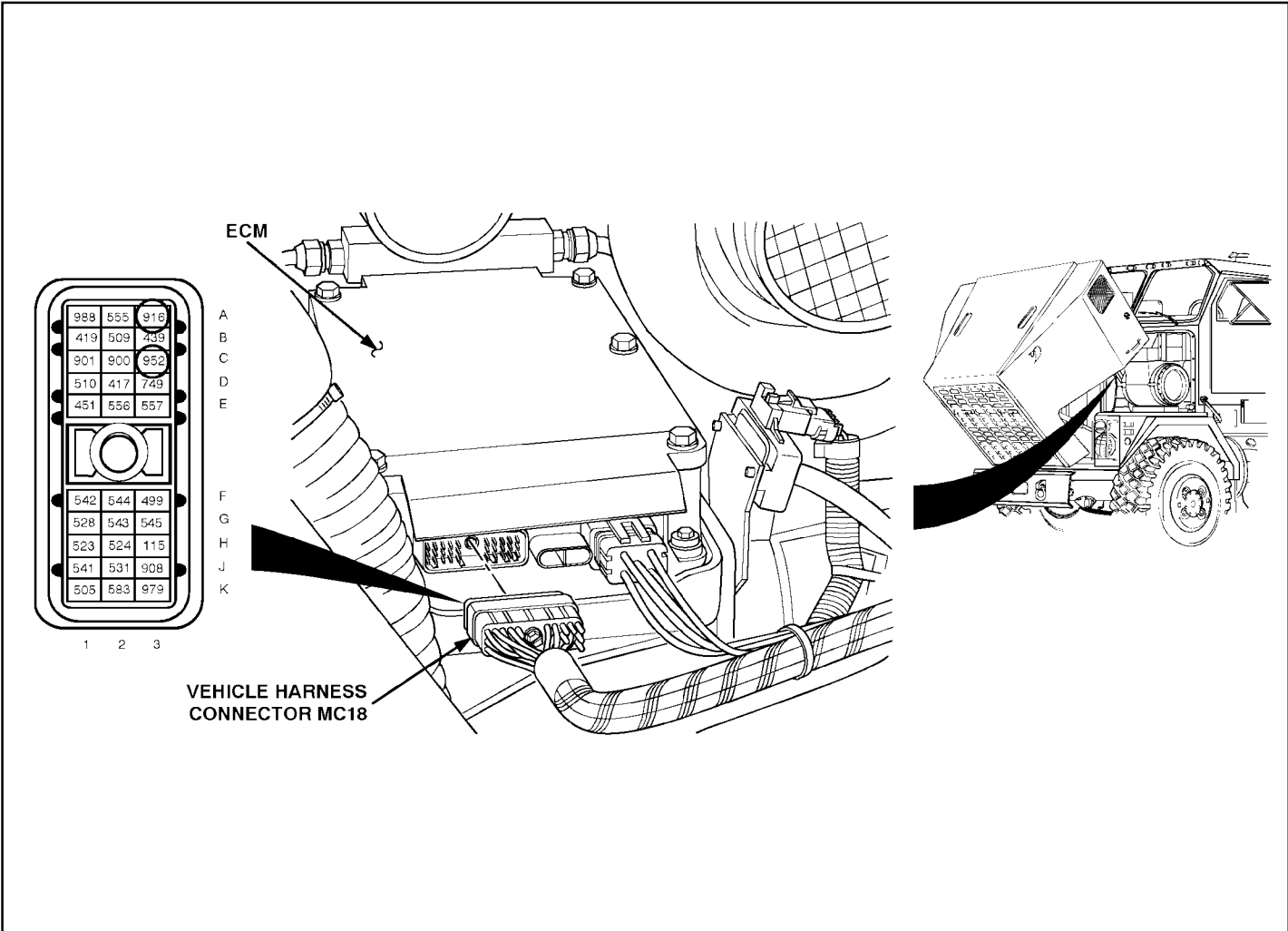

Section 4 TROUBLESHOOTING CHARTS

E. VEH5V - VEHICLE HARNESS +5 VOLTS SUPPLY

NOTE - This chart is only to be used if:

- 1) All basic mechanical checks and physical inspections have been performed with no problem found, and
- 2) Diagnosis of DDEC-III/IV was started at step START-10, pg H-25 and you have now been referred here.

STEP/SEQUENCE	RESULT	WHAT TO DO NEXT
<p>VEH5V-2 Check for Low Battery Voltage</p>		
<ul style="list-style-type: none"> • Was there also a Code 168/1? 	<p>Yes. </p> <p>No. </p>	<p>Go to 46-2 (page H-217).</p> <p>Go to VEH5V-2.</p>
<p>VEH5V-2 Check for +5 Volts at TPS</p>		
<ul style="list-style-type: none"> • Turn ignition off. • Disconnect the Throttle Position Sensor (TPS) connector. • Turn ignition on. • Read voltage on the TPS connector, pin C (red lead) to pin A (black lead). 	<p>Less than 4.7 volts.</p> <p>Greater than 5.2 volts.</p> <p>Between 4.7 and 5.2 volts.</p>	<p>Go to VEH5V-3.</p> <p>Go to VEH5V-11.</p> <p>Go to VEH5V-8.</p>
<p>VEH5V-3 Check for +5 Volts or Return Open</p>		
<ul style="list-style-type: none"> • Turn ignition off. • Disconnect the vehicle harness connector at the ECM. • Install a jumper wire between pins A and C of the TPS connector. • Read resistance between sockets A3 and C3 of the vehicle harness connector. 	<p>Less than or equal to 5 ohms.</p> <p>Greater than 5 ohms or open.</p>	<p>Go to VEH5V-4.</p> <p>Either the engine +5 volt line (ckt #916) or the sensor return line (ckt #952) is open. Repair open. Then go to VEH5V-30.</p>

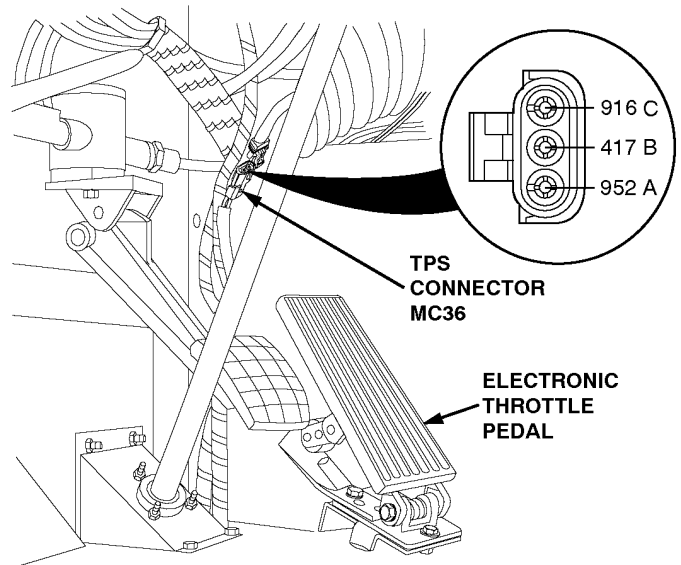
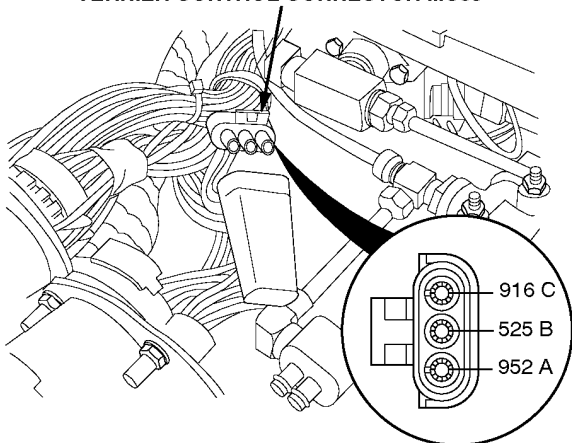
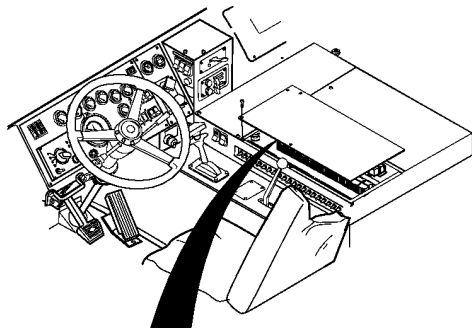
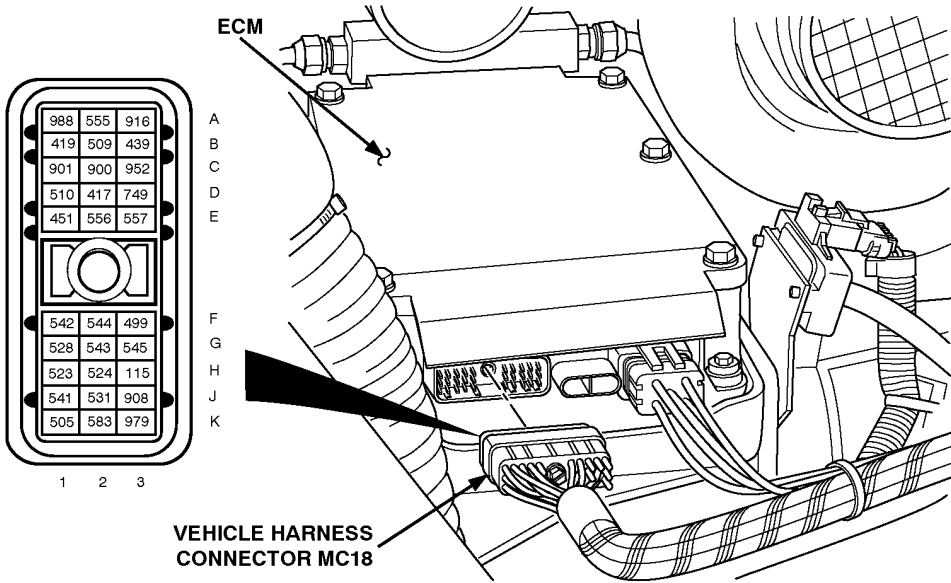

Section 4 TROUBLESHOOTING CHARTS

E. VEH5V - VEHICLE HARNESS +5 VOLTS SUPPLY (CONT'D)

STEP/SEQUENCE	RESULT	WHAT TO DO NEXT
<p>VEH5V-4 Check for +5 Volt Short Ground</p>		
<ul style="list-style-type: none"> • Remove jumper wire. • Disconnect vernier control (para 7-76). • Read resistance between pins A and C of the TPS connector. • Also read resistance between pin C or the TPS connector and a good ground. 	<p>Both readings are greater than 10,000 ohms or open. →</p> <p>Either reading is less than or equal to 10,000 ohms. →</p>	<p>Go to VEH5V-10.</p> <p>Go to VEH5V-6.</p>
<p>VEH5V-5 (Deleted)</p>		
<p>VEH5V-6 +5 Volts Check Using the Vernier Control</p>		
<ul style="list-style-type: none"> • Turn ignition on. • Read voltage on the vernier control connector, socket C (red lead) to socket A (black lead). 	<p>Less than 4.7 volts. →</p> <p>Greater than or equal to 4.7 volts. →</p>	<p>The engine +5 volt line (ckt #916) is shorted to either the sensor return line (ckt #952) or to chassis ground. Repair short. Then go to VEH5V-30.</p> <p>Go to VEH5V-12.</p>

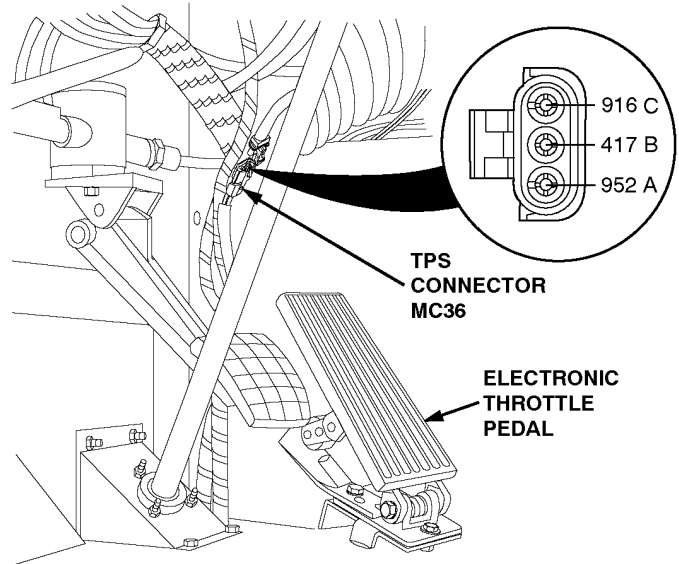
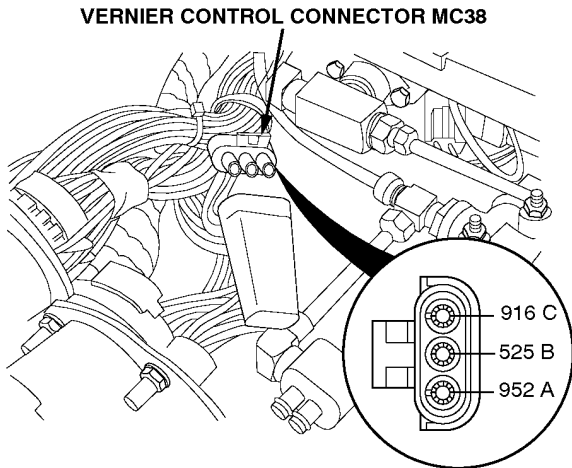
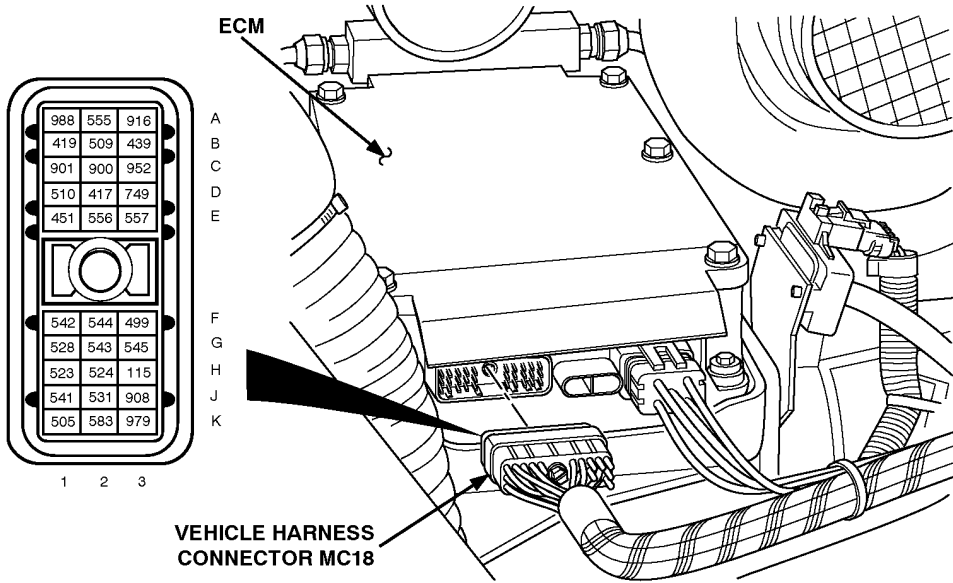

Section 4 TROUBLESHOOTING CHARTS

E. VEH5V - VEHICLE HARNESS +5 VOLTS SUPPLY (CONT'D)

STEP/SEQUENCE	RESULT	WHAT TO DO NEXT
<p>VEH5V-7 Check Vernier Control Sensor Connectors</p>		
<ul style="list-style-type: none"> • Inspect terminals at the vernier control connectors (sensor side and harness side) for damage; bent, corroded and unseated pins or sockets. 	<p>Terminals and connectors are okay. →</p> <p>Problem found. →</p>	<p>Replace vernier control (para 7-76). Then go to VEH5V-30.</p> <p>Repair terminals/connectors (para 7-77). Then go to VEH5V-30.</p>
<p>VEH5V-8 Check TPS</p>		
<ul style="list-style-type: none"> • Turn ignition off. • Reconnect the Throttle Position Sensor (TPS) connector. • Turn ignition on. • Select TPS CNTS for display on the DDR. • Observe throttle counts at both no throttle and full throttle (engine not running). 	<p>Getting 64-205 counts at no throttle and no more than 968 counts at full throttle. →</p> <p>Not getting the above readings. →</p>	<p>Go to VEH5V-10.</p> <p>Go to VEH5V-9.</p>
<p>VEH5V-9 Check TPS Connectors</p>		
<ul style="list-style-type: none"> • Turn ignition off. • Disconnect the Throttle Position Sensor (TPS) connector. • Inspect terminals at the TPS connectors (sensor side and harness side) for damage; bent, corroded and unseated pins or sockets. 	<p>Terminals and connectors are okay. →</p> <p>Problem found. →</p>	<p>Replace TPS (Electronic Throttle) (para 7-28). Then go to VEH5V-30.</p> <p>Repair terminals/connectors (para 7-77). Then go to VEH5V-30.</p>

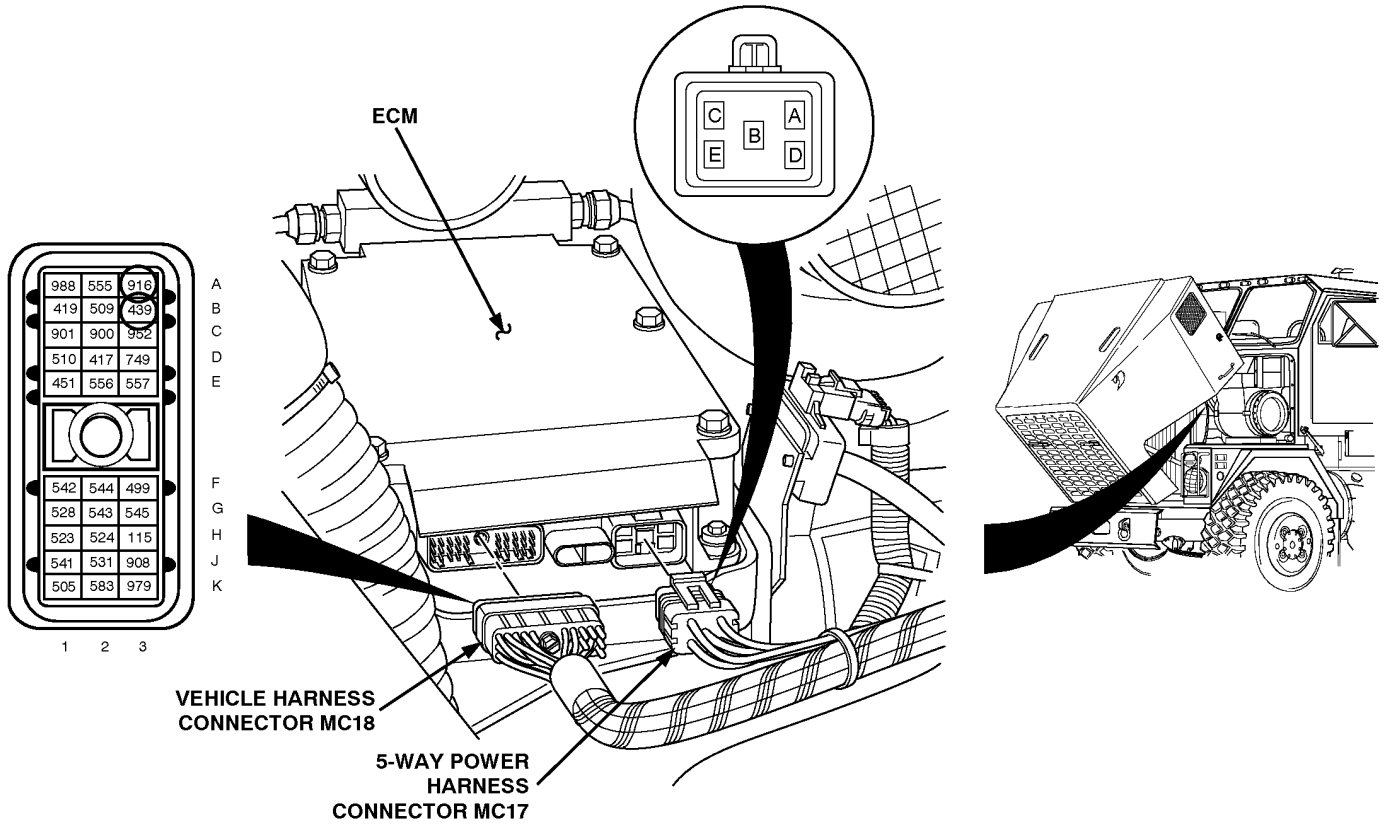

VERNIER CONTROL CONNECTOR MC38

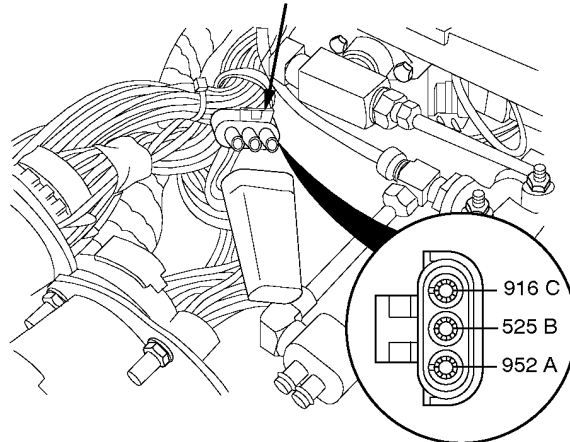

Section 4 TROUBLESHOOTING CHARTS

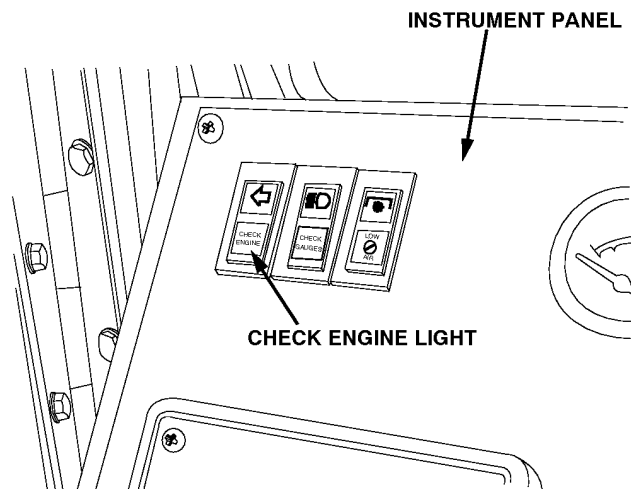

E. VEH5V - VEHICLE HARNESS +5 VOLTS SUPPLY (CONT'D)

STEP/SEQUENCE	RESULT	WHAT TO DO NEXT
<p>VEH5V-10 Check ECM Connectors</p> <ul style="list-style-type: none"> • Turn ignition off. • Disconnect the vehicle harness connector at the ECM (if not already disconnected). • Check terminals at the vehicle harness connector (both the ECM and harness side) for damage; bent, corroded and unseated pins or sockets. Especially terminals #952, #916, #417, and #510. Install new terminal if in doubt. 	<p>Terminals and connectors are okay. →</p> <p>Problem found. →</p>	<p>Replace ECM (para 7-29.1). Then go to VEH5V-30.</p> <p>Repair terminals/connectors (para 7-77). Then go to VEH5V-30.</p>
<p>VEH5V-11 Check for Short to Battery +</p> <ul style="list-style-type: none"> • Turn ignition off. • Disconnect batteries (para 7-61). • Disconnect the vehicle harness and 5-way power harness connectors at the ECM. • Read resistance between sockets A3 and B3 on the vehicle harness connector. • Also read resistance between socket A3 on the vehicle harness connector and the following sockets on the 5-way power harness connector: A and C. 	<p>All readings are greater than 10,000 ohms or open. →</p> <p>Any reading is less than 10,000 ohms. →</p>	<p>Go to VEH5V-10.</p> <p>A short exists between the engine +5 volt line (ckt #916) and the line(s) where less than 10,000 ohms was read (either: ckt #240, #241, or #439). Repair short. Then go to VEH5V-30.</p>
<p>VEH5V-12 Open Check</p> <ul style="list-style-type: none"> • Connect TPS connector. • Turn ignition on. • Read voltage on vernier control connector, socket C (red lead) and a good battery ground. • Repeat above only place red lead is socket A of the vernier control connector. 	<p>Both 4.7 to 5.2 volts. →</p> <p>Pin C greater than 4.7 volts and pin A is zero volts. →</p>	<p>Repair open from ckt #952 to ECM. (Look at ECM terminal.) Repair open, then go to VEH5V-30.</p> <p>Go to VEH5V-7.</p>



Section 4 TROUBLESHOOTING CHARTS

E. VEH5V - VEHICLE HARNESS +5 VOLTS SUPPLY (CONT'D)

STEP/SEQUENCE	RESULT	WHAT TO DO NEXT
<p>VEH5V-30 Verify Repairs</p> <ul style="list-style-type: none"> • Turn ignition off. • Reconnect all connectors. • Turn ignition on. • Clear codes. • If "Check Engine" light does not stay on, start engine and run (TM 9-2320-360-10) until "Check Engine" light comes on for 1 minute. • Stop engine. • Read inactive codes. 	<p>No codes. </p> <p>Codes which brought you to Chart VEH5V are still there. </p> <p>Any codes except those which brought you to Chart VEH5V. </p>	<p>Repairs are complete.</p> <p>Go to ENG5V-1, page H-241.</p> <p>Go to START-10, pg H-25, to service other codes.</p>

Section 10

DIAGNOSTIC DATA READER INFORMATION

This section describes the DDEC III information available through the use of the MPSI Pro-Link 9000 Diagnostic Data Reader (DDR). Pro-Link menu diagrams and parameter definitions are provided.

Engine Menu Selections and sub menus are defined as follows:

G. ENGINE DATA LIST

H. DIAGNOSTIC CODES

- Active Codes
- Inactive Codes
- Clear Codes
- Change Code Description

I. VIEW CALIBRATION CONFIGURATION SELECTIONS

- Engine Configuration
- VSG Configuration
- Engine Protection Configuration
- ECM Input and Output Configuration

J. FUEL INJECTOR INFORMATION

- Cylinder Cutout
- Response Times
- View Injector Calibration
- Update Injector Calibration

K. SWITCH/LIGHT STATUS

L. MID MESSAGES BEING RECEIVED

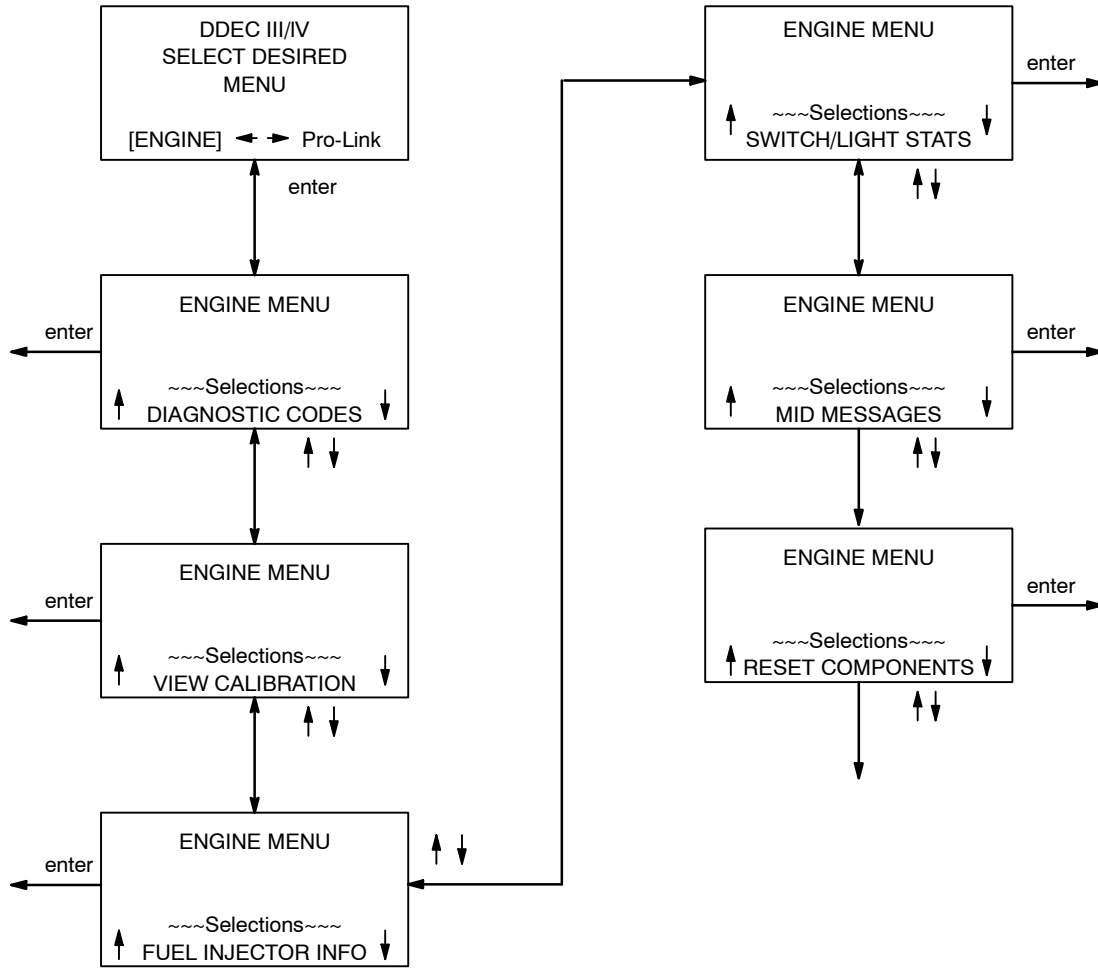

FIGURE 1

Section 10

DIAGNOSTIC DATA READER INFORMATION (Cont'd)

A. ENGINE DATA LIST

The Engine Data List menu selection displays the set of DDEC III/IV data parameters that pertain to the operation of the engine and vehicle.

NOTES:

- (1) Engine data list parameter values that are displayed as 'N/A' (not available) typically indicate that the sensor(s) and/or function is not part of the engine configuration, or the parameter data is not being transmitted by the DDEC III/IV ECM.
- (2) Engine sensor parameter values that are displayed as 'FAIL' is an indication that a FMI 3 (Sensor Voltage High) or a FMI 4 (Sensor Voltage Low) diagnostic condition is currently active for that sensor(s).

Parameter [1]: **ACTIVE CODES**

Definition: Indicates the presence of a condition(s) that causes the check engine light to be on.

Typical Range: YES or NO

Parameter [2]: **INACTIVE CODES**

Definition: Indication that past active codes have been stored in the ECM memory.

Typical Range: YES or NO

Parameter [3]: **ENGINE RPM**

Definition: Indicates engine RPM as determined by the Timing Reference Sensor (TRS).

Typical Range: 0 to 2500 RPM

Parameter [4]: **PULSEWIDTH**

Definition: Fuel Pulse Width – Number of degrees crankshaft rotation that the EUI's control valve is closed and fuel is entering the cylinder

Typical Range: 0.0 to 25.5 Degrees

Parameter [5]: **BOOST**

Definition: Boost Pressure – Pressure of air measured by the Turbo Boost Sensor (TBS) downstream on the compressor discharge side of the turbocharger.

Typical Range: (0.0 to 43.5 PSI) or (0 to 305 KPa)

Parameter [6]: **TPS CNTS**

Definition: Throttle Position Sensor (TPS) Counts (CNTS). Indicates the analog to digital (A/D) conversion of (0 to 5 volts) from the TPS to (0 to 1024 counts) that the ECM uses to compute the percent throttle opening.

Typical Range: (0 to 1024 Counts) or N/A

Parameter [7]: **TPS PCT**

Definition: Indicates the percent opening of the Throttle Position Sensor (TPS).

Typical Range: 0 to 100%

Parameter [8]: **VSG CNTS**

Definition: Variable Speed Governor (VSG) – A/D Counts. Indicates the analog to digital (A/D) conversion of (0 to 5 volts) from the VSG to (0 to 1024 counts) that the ECM uses to compute the VSG set RPM.

Typical Range: (0 to 1024 Counts) or N/A

Section 10

DIAGNOSTIC DATA READER INFORMATION (Cont'd)

Parameter [9]: VSG SETRPM

Definition: Indicates the engine set speed for the Variable Speed Governor.
Typical Range: (0 to 2500 RPM) or N/A

Parameter [10]: BOI

Definition: Beginning of Injection - Specifies the timing of the injection event as the number of degrees crankshaft rotation before piston TDC. This data is available for engineering purposes only.
Typical Range: (0.0 to 25.5 Degrees) or N/A

Parameter [11]: OIL TEMP

Definition: Indicates the temperature of the engine oil that is measured by the Oil Temperature Sensor (OTS) in degrees Fahrenheit or Celsius.
Typical Range: (-40 to 327 deg F) or (-40 to 150 deg C)

Parameter [12]: COOL TEMP

Definition: Indicates the temperature of the engine coolant that is measured by the Coolant Temperature Sensor (CTS) in degrees Fahrenheit or Celsius.
Typical Range: (-40 to 327 deg F) or (-40 to 150 deg C)

Parameter [13]: FUEL TEMP

Definition: Indicates the temperature of the engine fuel that is measured by the Fuel Temperature Sensor (FTS) in degrees Fahrenheit or Celsius.
Typical Range: (-40 to 214 deg F) or (-40 to 87 deg C)

Parameter [14]: AIR INLET TEMP

Definition: Indicates the temperature of the air entering the engine air induction system that is measured by the Air Temperature Sensor (ATS) in degrees Fahrenheit or Celsius.
Typical Range: (-40 to 214 deg F) or (-40 to 87 deg C)

Parameter [16]: OIL PRS

Definition: Indicates the engine oil pressure that is measured by the Oil Pressure Sensor (OPS) in PSI or KPa.
Typical Range: (0.0 to 64.0 PSI) or (0 to 448 KPa)

Parameter [18]: BARO PRS

Definition: Barometric Pressure - Indicates the atmospheric pressure in PSI or KPa.
Typical Range: (0.0 to 999.9 PSI) or (0 to 9999 KPa)

Parameter [23]: COOL LEVEL

Definition: Indicates the coolant level in the reservoir that is measured by the Coolant Level Sensor (CLS).
Typical Range: FULL or LOW

Parameter [25]: ENG LOAD PCT

Definition: Indicates the percent engine load calculated from engine speed and torque.
Typical Range: 0 to 100%

Parameter [26]: TORQUE LB-FT or N•M

Definition: Indicates the amount of torque available at the engine flywheel. Negative torque values will be displayed with a minus sign in front of the value.
Typical Range: -9999 to 9999 LB-FT / -9999 to 9999 N•M

Parameter [27]: ECM VOLTS

Definition: Indicates the battery voltage available to the ECM
Typical Range: 0.0 to 32.0 Volts

Section 10

DIAGNOSTIC DATA READER INFORMATION (Cont'd)

Parameter [28]: **VEHICLE SPD MPH or KPH**

Definition: Indicates the vehicle road speed in MPH or KPH.

Typical Range: (0 to 999 MPH / 0 to 999 KPH) or N/A

Parameter [30]: **SRS RECEIVED**

Definition: Indicates that the ECM has received a signal from the Synchronous Reference Sensor (SRS) during this ignition cycle.

Typical Range: YES or NO

Parameter [31]: **IDLE SPD RPM**

Definition: Indicates the current engine idle speed in RPM.

Typical Range: 0 to 1000 RPM

Parameter [32]: **ENG GOVR**

Definition: Indicates which DDEC governor is currently active.

Typical Range: NONE, IDLE, HIGH SPD, CRUISE, ROAD SPD, CRUZ VSG, H20 PGS

Parameter [33]: **%TQ LIMIT**

Definition: Torque Reduction Factor - Indicates the ratio of current output torque allowed (due to adverse operating conditions) to maximum torque available at current engine speed (under normal operating conditions).

Typical Range: 0 to 100%

Parameter [34]: **HALF ENGINE**

Definition: Indicates the active/inactive status of the Half Engine Mode.

Typical Range: YES or NO

Parameter [35]: **ENG BRAKE**

Definition: Indicates the active/inactive status of the engine brake.

Typical Range: LOW, MED, HIGH or OFF

Parameter [36]: **FUEL RATE**

Definition: Indicates the amount of fuel consumed by the engine per unit time.

Typical Range: 0.0 to 999.9 GPH / 0.0 to 999.9 LPH

Parameter [37]: **FUEL MPG or L/100km**

Definition: Indicates the current fuel economy at the current vehicle velocity.

Typical Range: 0.0 to 99.9 MPG / 0.0 to 99.9 L/100km

Parameter [41]: **OVERRIDE**

Definition: Indicates the active/inactive status of the idle shutdown override feature. 'N/A' will be displayed if 'ISD OPTION = DISABLED or N/A'.

Typical Range: ON, OFF, or N/A

Parameter [43]: **PWM DRIVE #1**

Definition: Indicates the active duty cycle of the Pulse Width Modulated (PWM) port #1.

Typical Range: 0 to 100%

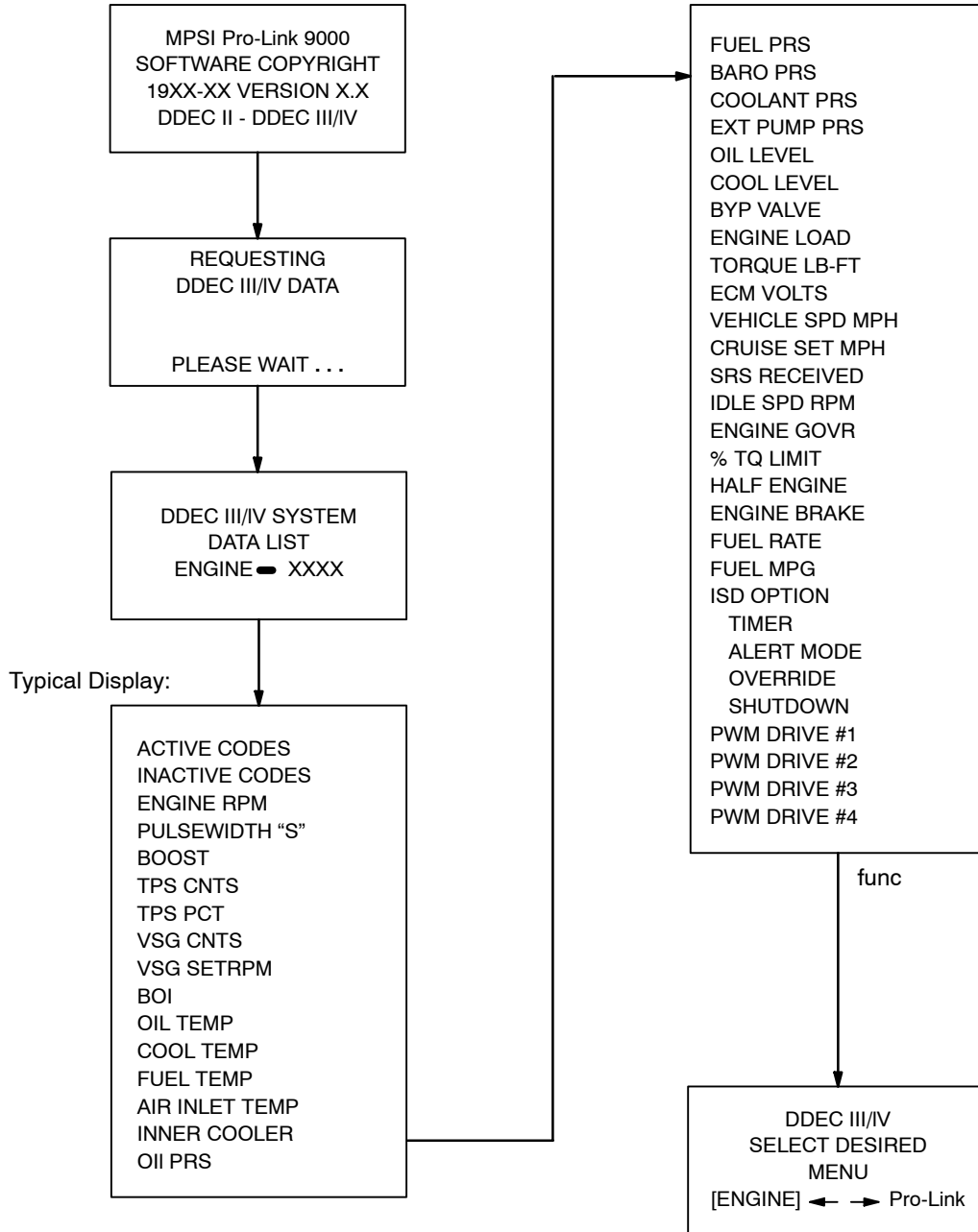

FIGURE 2

Section 10

DIAGNOSTIC DATA READER INFORMATION (Cont'd)

B. DIAGNOSTIC CODES

The Diagnostic Code Menu Selections are defined as follows:

- Active Codes
- Inactive Codes
- Clear Codes
- Change Code Description

MID Descriptions

MID: 128 ENGINE Single ECM applications

Diagnostic Codes with Subsystem Identification Characters (SIDs) reference DDEC III/IV Auxiliary Output #'s 1 - 8 (SIDs: 26) and use the looked-up parameter text description in TABLE 2 page H-278 to identify the function assigned to the auxiliary output channel.

Injector Response Time Codes Long and Injector Response Time Codes Short will use (TABLE 5 Injector Numbering) page H-279 to identify the appropriate engine cylinder number.

B.5 ACTIVE CODES

Active Codes are conditions that are presently occurring and causing the Check Engine Light (CEL) to be illuminated. The display for each code is as follows:

Line 1: MID:XXX ENGINE XX
 Line 2: PID Description
 Line 3: FMI Description
 Line 4: ↑A## PID:XXX FMI:XX↓

NOTES:

- (1) MID: Message Identification Character
- (2) PID: Parameter Identification Character
- (3) FMI: Failure Mode Identifier
- (4) A##: Numerical Count of Active Codes
- (5) ↑↓: Indicates additional codes are stored in ECM memory

Section 10 DIAGNOSTIC DATA READER INFORMATION (Cont'd)

B.6 INACTIVE CODES

Inactive Codes are faults that have occurred previously. The display for each code is as follows:

SCREEN #1

Line 1: MID:XXX ENGINE XX
 Line 2: PID Description
 Line 3: FMI Description
 Line 4: ↑I## PID:XXX FMI:XX↓

SCREEN #2

Line 5: 1st: Last:
 Line 6: Total#:
 Line 7: Total Time:
 Line 8: Min/Max:

NOTES:

- (1) I##: Numerical Count of Inactive Codes
- (2) 1st: First occurrence of the diagnostic code in engine hours
- (3) Last: Last occurrence of the diagnostic code in engine hours
- (4) Total#: Total number of occurrences
- (5) Total Time: Total engine seconds that the diagnostic code was active
- (6) Min/Max: Minimum/Maximum value recorded during diagnostic condition

B.7 CLEAR CODES

This function allows diagnostic codes stored in the ECM(s) to be erased. An audit trail of when the codes were last erased in engine hours will be displayed.

B.8 CHANGE CODE DESCRIPTION

This function allows the user to specify the type of diagnostic code description by selecting either DDEC or J1587. With J1587 selected, the codes are identified according to the J1587 specification developed by the Society of Automotive Engineers (SAE) and the American Trucking Association (ATA).

If you are using J-1587 code description, the readout resembles this:

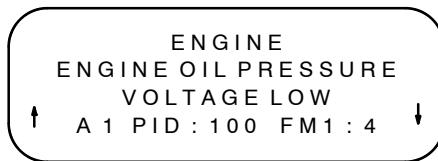

If you are using DDEC code description, the readout resembles this:

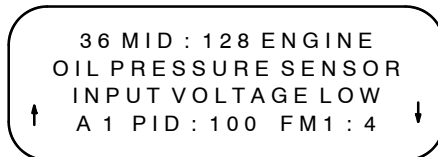

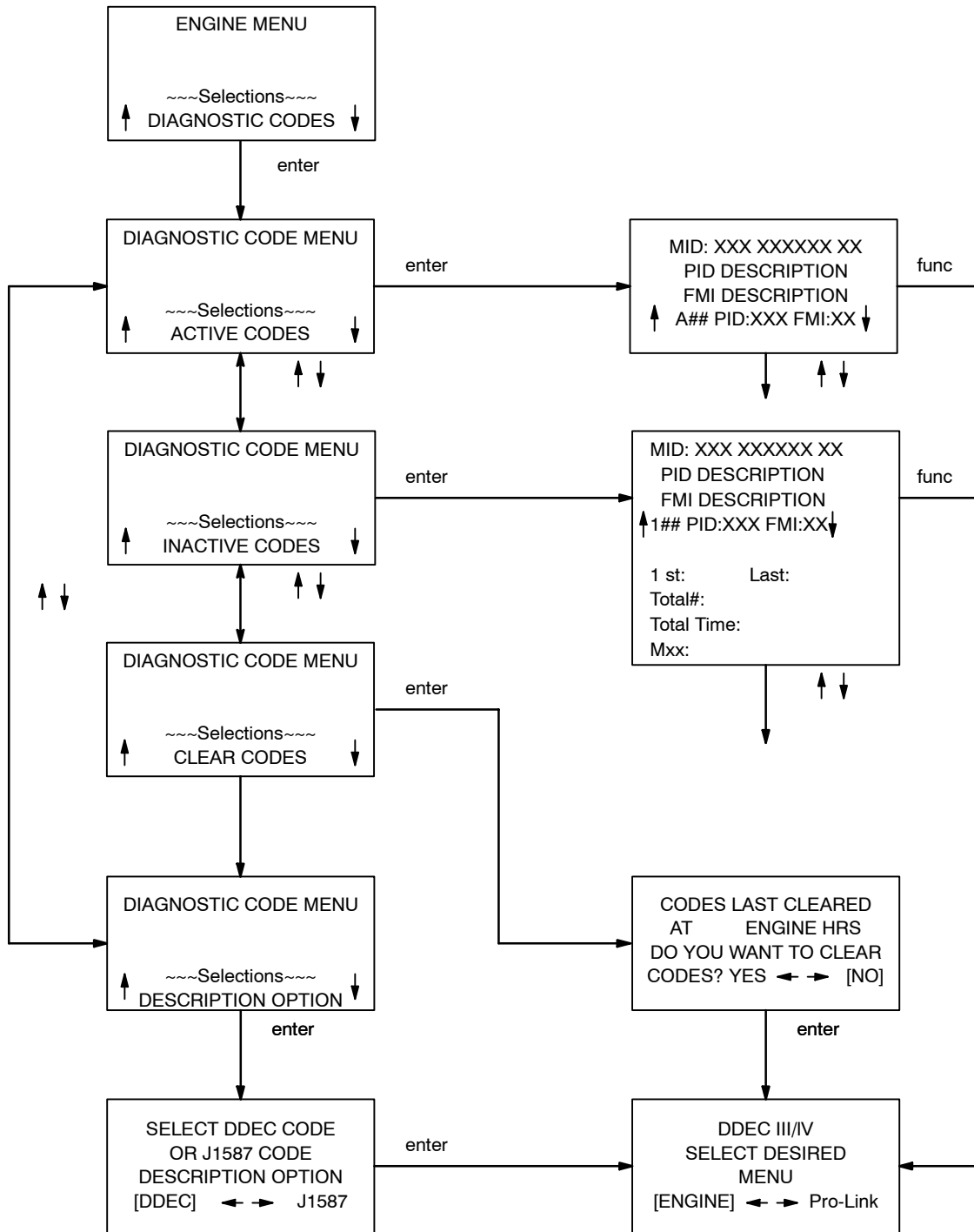

FIGURE 3

Section 10
DIAGNOSTIC DATA READER INFORMATION (Cont'd)

C. VIEW CALIBRATION CONFIGURATION SELECTIONS

The View Calibration Configuration Menus are a set of selections that allow the viewing of engine and vehicle operating parameters that are stored in the DDEC III Electrically Erasable Programmable Read Only Memory (EEPROM). These parameters are typically referred to as the DDEC ECM calibration parameters.

View Calibration Configuration Menu Selections are defined as follows:

- Engine Configuration
- VSG Configuration
- Engine Protection Configuration
- ECM Input and Output Configuration

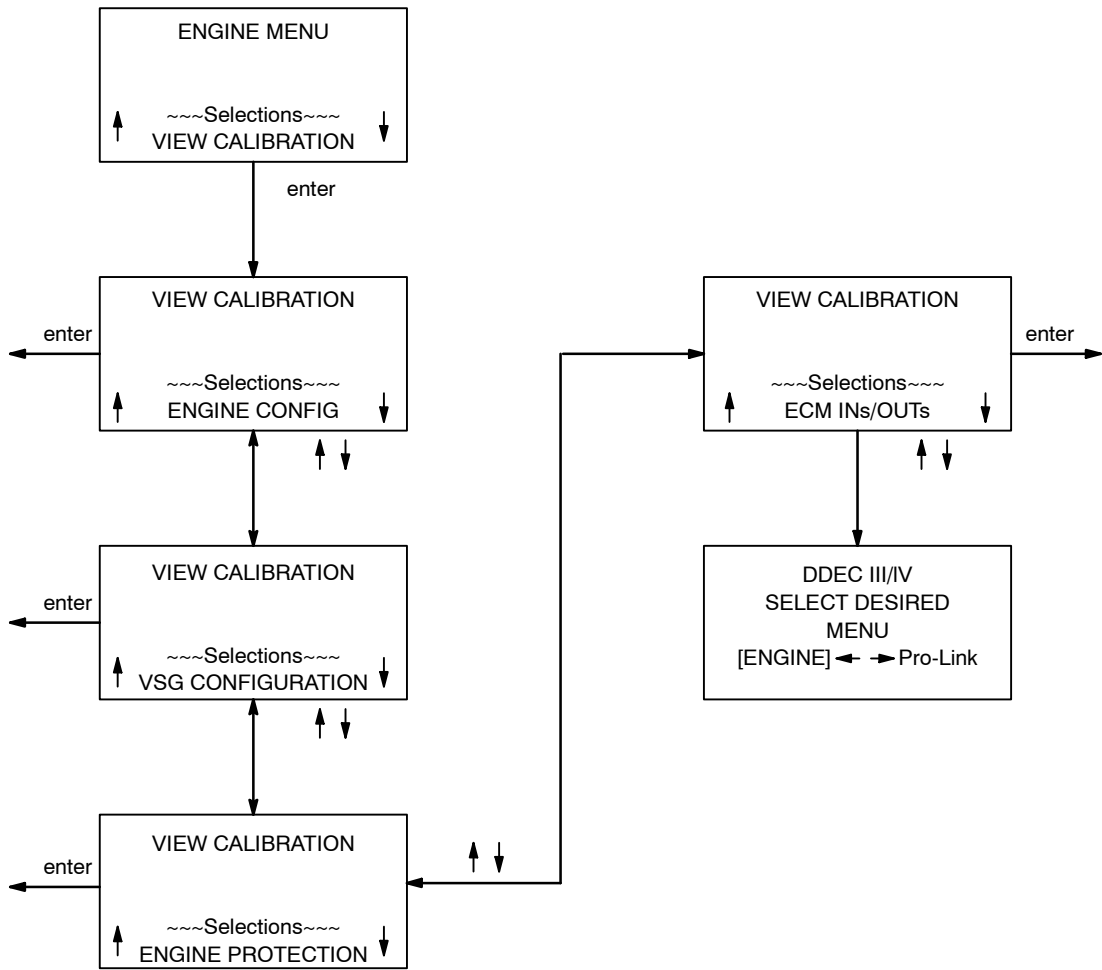

FIGURE 4

Section 10

DIAGNOSTIC DATA READER INFORMATION (Cont'd)

C.1 ENGINE CONFIGURATION

The view Engine Configuration menu selection displays the parameter list that describes engine identification, application and rating information that is currently programmed in the calibration. DDEC III ECM identification and software information is also provided.

Parameter [1]: **ENGINE MODEL#**

Definition: Indicates the Detroit Diesel Corporation engine model number.

Typical Range: 8 Characters

Parameter [2]: **6N4M#**

Definition: Indicates the engine rating group designation.

Typical Range: 1 to 9999

Parameter [3]: **6N4D#**

Definition: Indicates the engine rating family designation.

Typical Range: 1 to 9999

Parameter [4]: **6N4C#**

Definition: Indicates the engine application group designation.

Typical Range: 1 to 9999

Parameter [5]: **V**

Definition: Indicates the vehicle identification number.

Typical Range: 17 Characters

Section 10

DIAGNOSTIC DATA READER INFORMATION (Cont'd)

Parameter [6]: **ENGINE SN**

Definition: Indicates the engine serial number.
Typical Range: 10 Characters

Parameter [7]: **ECM SN**

Definition: Indicates the ECM serial number.
Typical Range: 8 Characters ASCII

Parameter [8]: **SOFTWARE LVL**

Definition: Indicates the DDEC ECM software version. The software level is incremented after every revision.
Typical Range: 0.00 to 999.99

Parameter [9]: **EPA CERT#**

Definition: Indicates the EPA engine certification number.
Typical Range: 1 to 999

Parameter [10]: **ENGINE SERIES**

Definition: Indicates the DDEC engine type.
Typical Range:

Parameter [11]: **ENGINE POWER BHP or KW**

Definition: Indicates the active engine rated horse power.
Typical Range: 0 to 9999 BHP / 0 to 9999 KW

Parameter [12]: **RATED ENGINE RPM**

Definition: Indicates the rated speed.
Typical Range: 0 to 9999 RPM

Parameter [13]: **LSG DROOP RPM**

Definition: Indicates the engine rated speed governor droop.
Typical Range: 0 to 999 RPM

Parameter [14]: **PEAK TRQ FT-LB or N•M**

Definition: Indicates the engine peak operating torque.
Typical Range: 0 to 9999 FT-LB / 0 to 9999 N•M

Section 10
DIAGNOSTIC DATA READER INFORMATION (Cont'd)

Parameter [15]: **PEAK TRQ RPM**

Definition: Indicates the engine RPM at peak torque.
Typical Range: 0 to 2500 RPM

Parameter [16]: **IDLE SPEED RPM**

Definition: Indicates the WARM engine idle speed.
Typical Range: 0 to 1000 RPM

Parameter [17]: **IDLE ADJUST**

Definition: Indicates the idle RPM adjustment.
Typical Range: -25 to 150 RPM

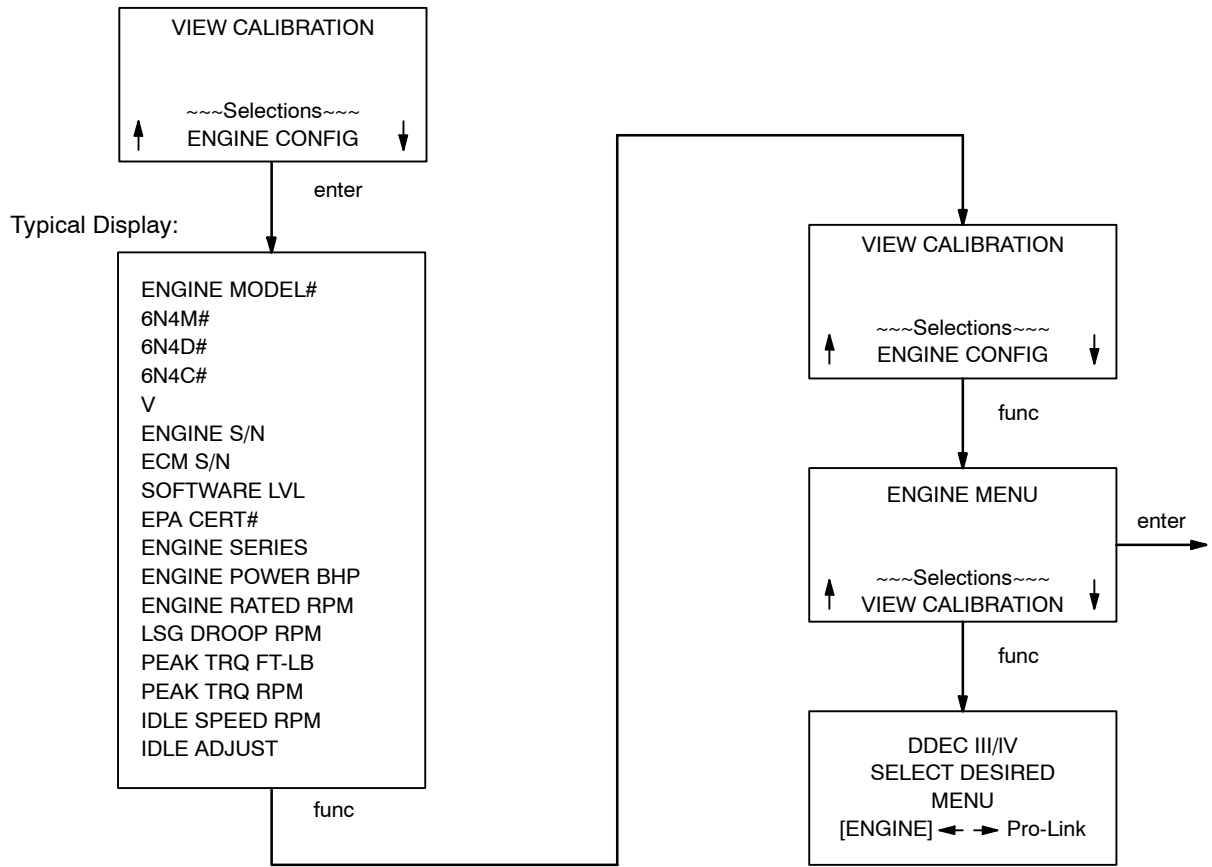

FIGURE 5

Section 10

DIAGNOSTIC DATA READER INFORMATION (Cont'd)

C.2 VSG CONFIGURATION

The view VSG Configuration selection is the set of DDEC III/IV data parameters that identifies the Variable Speed Governor (VSG) configuration that is currently programmed in the DDEC III/IV calibration.

Parameter [1]: **VSG DROOP RPM**

Definition: Indicates the variable speed governor droop in RPM.

Typical Range: 0 to 300 RPM

Parameter [2]: **VSG MIN RPM**

Definition: Indicates the minimum variable speed governor RPM.

Typical Range: ("IDLE" to "VSG MAX RPM") "IDLE" = DDEC Unique ID 218 - Byte a

Parameter [3]: **VSG MAX RPM**

Definition: Indicates the maximum variable speed governor RPM.

Typical Range: ("VSG MIN RPM" to "RATED") RPM

Parameter [4]: **ALT VSG MIN**

Definition: Indicates the alternate variable speed governor minimum RPM. 'N/A' will be displayed if (Function #16 -- ALT VSG MIN) is not configured as a vehicle input switch.

Typical Range: ("VSG MIN RPM" to "VSG MAX RPM") RPM, or N/A.

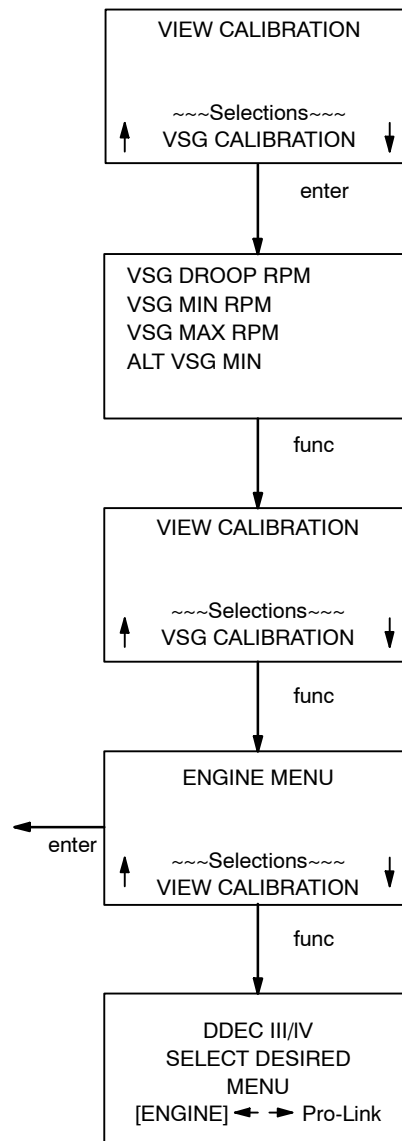

FIGURE 6

Section 10

DIAGNOSTIC DATA READER INFORMATION (Cont'd)

C.3 ENGINE PROTECTION CONFIGURATION

The view Engine Protection Configuration selection is the set of DDEC III/IV data parameters that identifies to the type of engine protection configuration that is currently programmed in the DDEC III/IV calibration.

NOTES:

- (1) Engine protection parameter values that are displayed as 'N/A' (not available) typically indicate that the sensor(s) and/or function is not part of the engine configuration.

Parameter [1]: **OIL TEMP**

Definition: Indication of the type of engine protection based on high engine oil temp.

Typical Range: Warn, Ramp, Shtdwn

Parameter [2]: **COOLANT TMP**

Definition: Indication of the type of engine protection based on high engine coolant temp.

Typical Range: Warn, Ramp, Shtdwn

Parameter [3]: **OIL PRS**

Definition: Indication of the type of engine protection based on low engine oil pressure.

Typical Range: Warn, Ramp, Shtdwn

Parameter [6]: **COOLANT LVL**

Definition: Indication of the type of engine protection based on low coolant level.

Typical Range: Warn, Ramp, Shtdwn

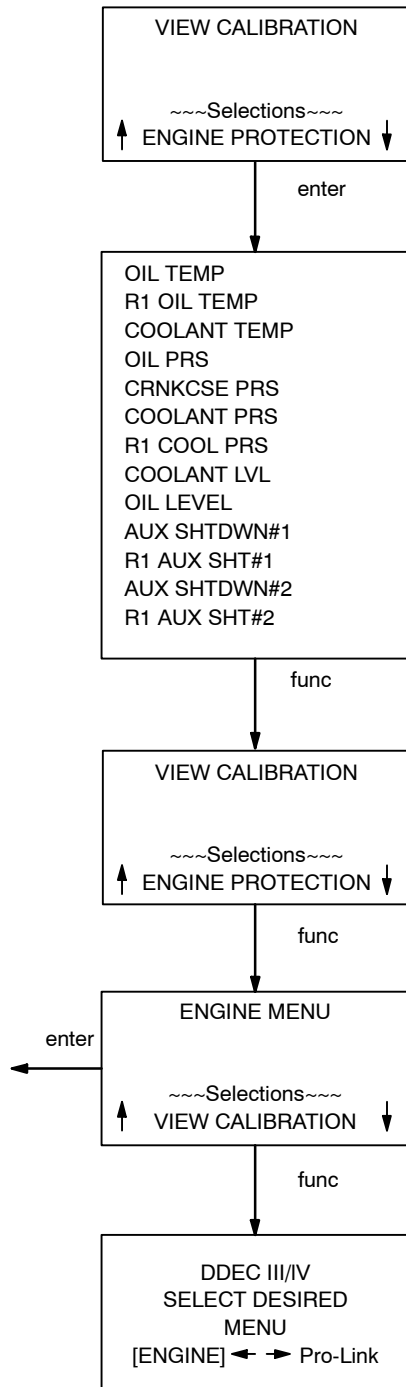

FIGURE 7

Section 10

DIAGNOSTIC DATA READER INFORMATION (Cont'd)

C.4 ECM INPUT AND OUTPUT CONFIGURATION

The view ECM Input and Output Configuration selection is the set of DDEC III/IV data parameters that describe the functions assigned to the ECM input and output connector terminals that is currently programmed in the DDEC III/IV calibration.

NOTES:

- (1) The connector cavity designations describe the physical locations of the assigned functions.
- (2) The DDR displays the assigned function parameter text as described in Table 1 (Vehicle Switch Input Options) and Table 2 (ECM Output Options) on page H-278.
- (3) 'N/A' will be displayed if a function number of (0 = NONE) has been assigned to any of the connector cavities.

Parameter [7]: **G1** -----

Definition: Indicates the functional configuration of the switch input at connector cavity G1 (diagnostic request switch).

Parameter [22]: **A1** -----

Definition: Indicates the functional configuration of the output at connector cavity A1 (engine brake enable).

Parameter [23]: **J3** -----

Definition: Indicates the functional configuration of the PWM output at connector cavity J3 (power train demand).

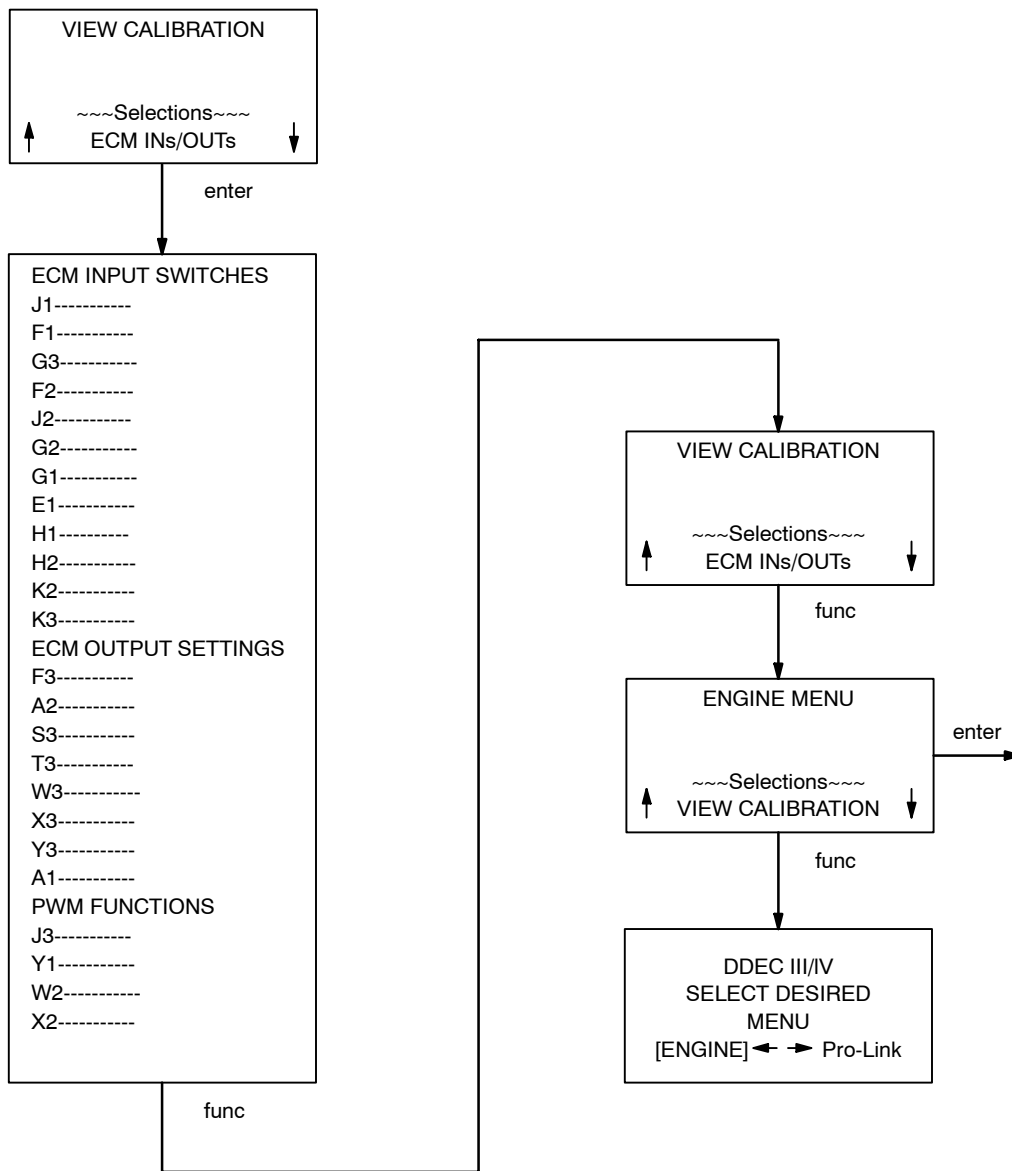

FIGURE 8

TABLE 1			
Vehicle Switch Input Options			
#	12345678901234567890	#	12345678901234567890
0	XX NONE	1	XX ENGINE BRK LOW
2	XX ENGINE BRK MED	3	XX AUX SHTDWN#1
4	XX AUX SHTDWN#2	5	XX PARK BRK/ISD
6	XX IDLE VALID	7	XX N/A
8	XX PRS/RPM MODE	9	XX TPS INHIBIT
10	XX RPM SYNC	11	XX RPM FREEZE
12	XX ENGINE RATE SW1	13	XX ENGINE RATE SW2
14	XX 2ND TQ CURVE	15	XX DIAG REQUEST
16	XX ALT MIN VSG	17	XX SERV BRK REL
18	XX CLUTCH REL	19	XX SET/COASTOFF
20	XX SET/COAST ON	21	XX RES/ACCELOFF
22	XX RES/ACCEL ON	23	XX CRUZ ENABLE
24	XX PGS SYS ENAB	25	XX SEO/DIAG REQ
26	XX ENGINE BRK DISA	27	XX N/A
28	XX DUAL THROTT	29	XX A/C PRESSURE
30	XX N/A	31	XX AUX CLS
32	XX FAN OVERRIDE		

TABLE 2			
ECM Output Options			
#	12345678901234567890	#	12345678901234567890
0	XX NONE	1	XX ENGINE BRK LOW
2	XX ENGINE BRK MED	3	XX LO DDEC VOLT
4	XX RPM SYNC LT	5	XX PGS ACTIVE
6	XX VEH PWR DOWN	7	XX STRT LOCKOUT
8	XX EXT ENGINE BRK	9	XX TRANS RET
10	XX COOL LOW LT	11	XX CRUZ ACTIVE
12	XX N/A	13	XX FAN CNTRL#1
14	XX FAN CNTRL#2	15	XX DECEL LT
16	XX ENGINE BRK ACT	17	XX VSG ACTIVE

TABLE 3			
Transmission Options			
#	12345678901234567890	#	12345678901234567890
0	J3 MANUAL	1	J3 ALLISON HYD
2	J3 N/A	3	J3 VOITH AUTO
4	J3 Z-F ECOMAT	5	J3 CEEMAT
6	J3 RENK	7	J3 N/A
8	J3 ELECTRIC DRIVE	9	3 ALLISON ELECT
10	J3 MARINE GEAR	11	J3 NO TRANSMISSION
12	J3 ALLISION WT	13	J3 N/A
14	J3 AUTOMATIC		

TABLE 4			
PWM Function Options			
#	12345678901234567890	#	12345678901234567890
0	XX NONE	1	XX BYPASS BLOWER
2	XX GLOW PLUGS	3	XX THROTTLE POS
4	XX FINAL TORQUE	5	XX PWR TRAIN DEMAND
6	XX FAN CONTROL		

TABLE 5		
Injector Numbering		
SIDS	FIRING ORDER	CYLINDER
S001	1	3 Right
S002	2	3 Left
S003	3	4 Right
S004	4	4 Left
S005	5	2 Right
S006	6	2 Left
S007	7	1 Right
S008	8	1 Left

Section 10 DIAGNOSTIC DATA READER INFORMATION (Cont'd)

D. FUEL INJECTOR INFORMATION

Fuel Injector Menu Selections are defined as follows:

- Cylinder Cutout
- Response Times
- View Injector Calibration
- Update Injector Calibration

D.5 CYLINDER CUTOUT

The cylinder cutout function provides a test method to locate a injector whose pulse width output is different from the others. This is done by cutting out one injector at a time and comparing the resulting injector pulse width with the no cut-out pulse width established before the first cylinder was cutout.

Cylinder cutout test options:

- (1) Run New Test or Review Last Results
- (2) Select RPM Setting: IDLE or 1000 RPM
- (3) Automatic Test or Manual Test

D.6 RESPONSE TIMES

The injector solenoid response times are defined as the time it takes from when the DDEC III/IV ECM requests an injector be turned on to when the injector solenoid valve actually closes.

Injector response times generally increase with low battery supply voltage and decrease with high battery supply voltage. Although injector response times vary from injector to injector at a given RPM, each individual injector response time should remain relatively consistent from one firing to the next. Wide variations in response time (typically +/- 0.2 msec) for one injector at a steady RPM may indicate an electrical problem (faulty alternator or voltage regulator, poor or broken ground cables, etc.).

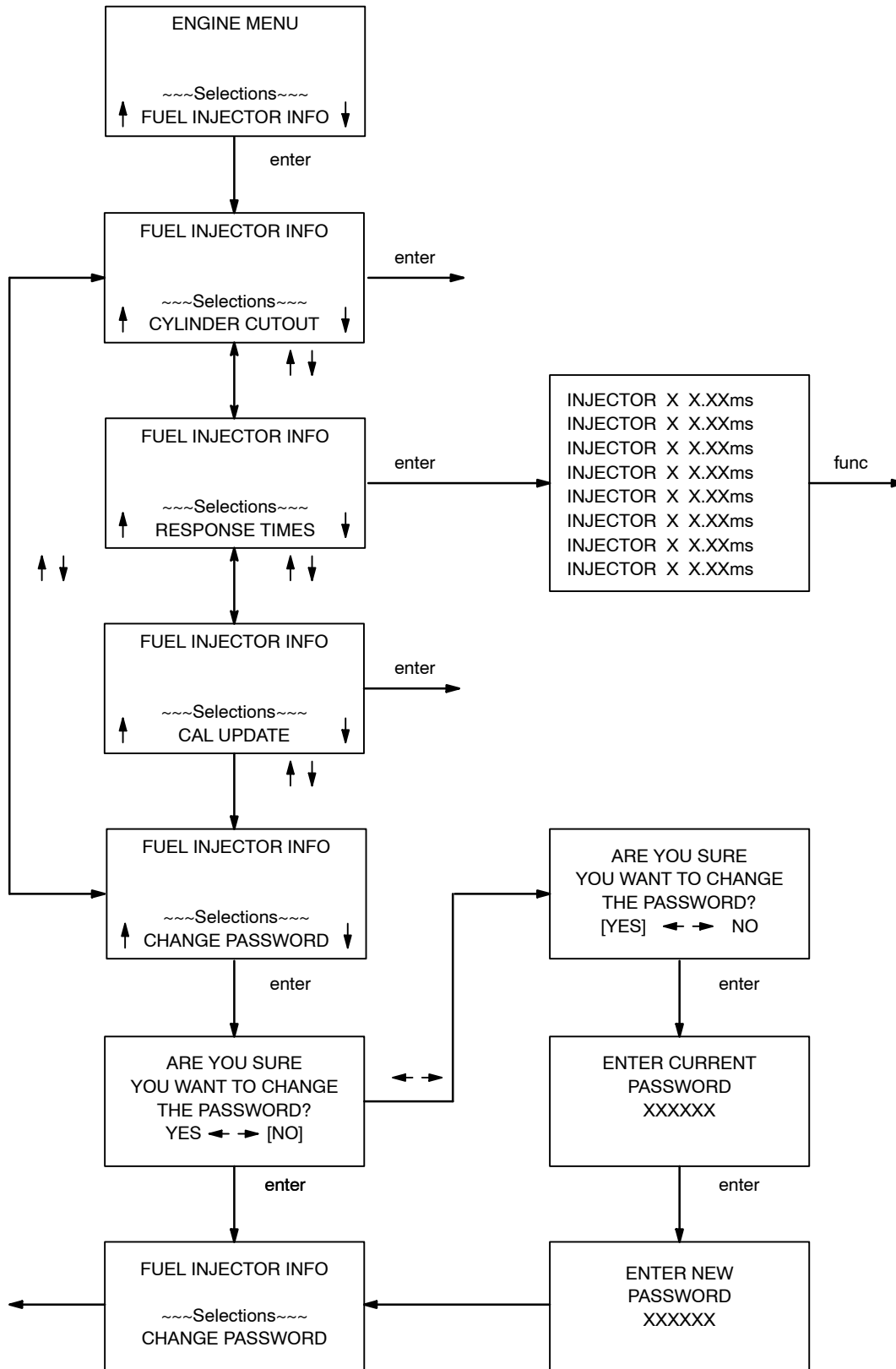

FIGURE 9

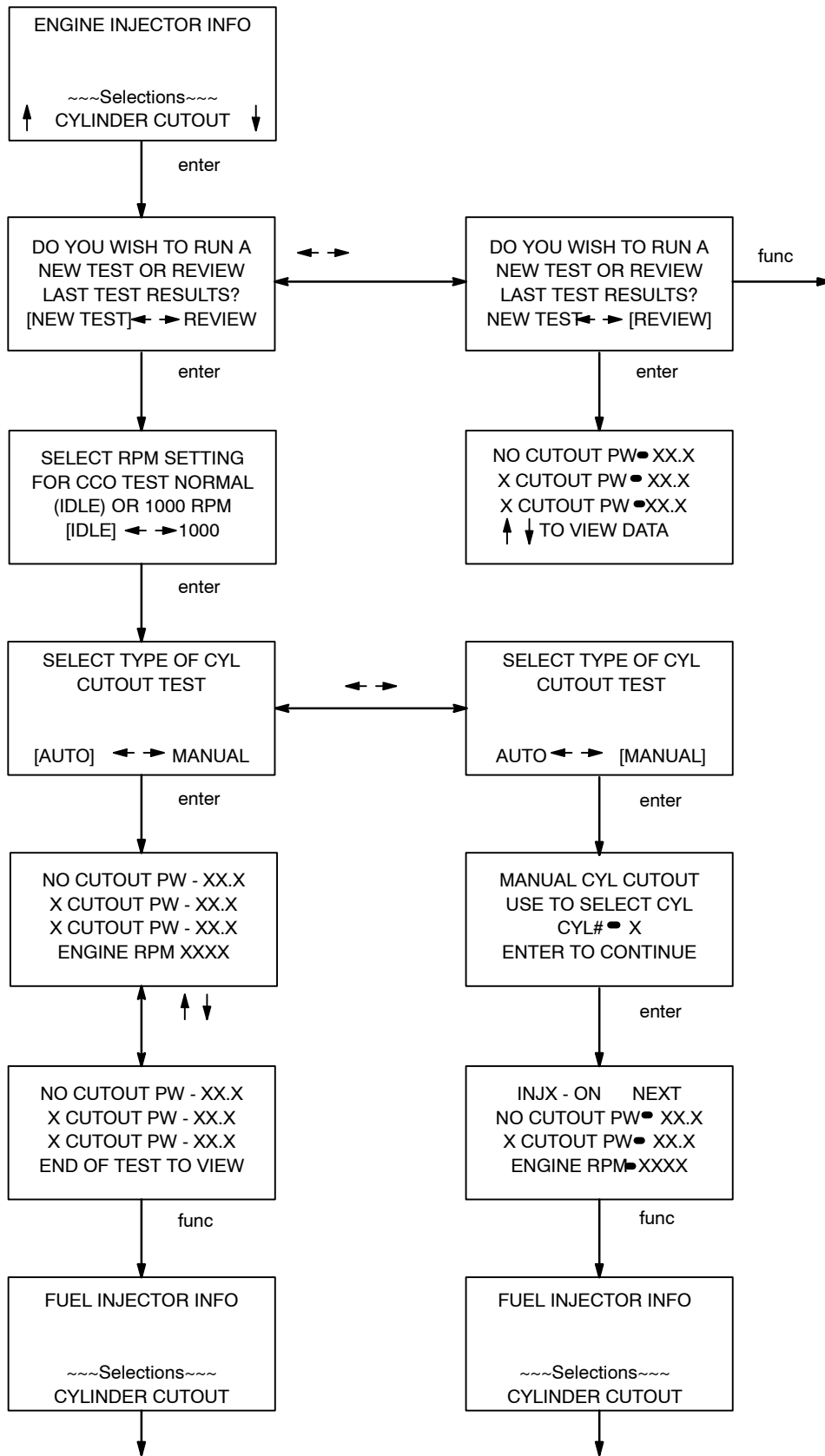

FIGURE 10

Section 10

DIAGNOSTIC DATA READER INFORMATION (Cont'd)

D.7 VIEW INJECTOR CALIBRATION

The injector calibration codes are used by the DDEC III/IV ECM to equalize the engine injector outputs. This compensation, obtained from properly programmed calibration codes, allows the DDEC III/IV ECM to perform optimum cylinder to cylinder power balancing.

NOTES:

- (1) The engine cylinder numbers use TABLE 5 (Injector Numbering) page H-279 to identify the appropriate injector cylinder calibration code.
- (2) Each injector typically has a unique calibration code which is physically indicated on the injector label.

Parameters [1-Number of Cylinders]: **CYL #XXX CAL XX**

Definition: Indicates the injector calibration that is currently programmed in the ECM.

Typical Range: CYL(#1 to # of cylinders) / CAL(0 to 99)

Parameter [2]: **LAST UPDATE:**

Definition: Indicates the engine hours of the last injector calibration update.

Typical Range: 0 to 65000 Hours

Parameter [3]: **TOOL ID:**

Definition: Indicates the tool identification number used for last injector cal update.

Typical Range: 8 ASCII Characters

Parameter [4]: **# OF CHANGES:**

Definition: Indicates the total number of injector calibration updates.

Typical Range: 0 to 255

D.8 UPDATE INJECTOR CALIBRATION

The Update Calibration selection allows the reprogramming of the injector calibration codes.

NOTES:

- (1) The engine cylinder numbers use TABLE 5 (Injector Numbering) page H-279 to identify the appropriate injector cylinder calibration code.
- (2) Each injector typically has a unique calibration code which is physically indicated on the injector label.

Parameters [1-Number of Cylinders]: **CYL #XXX CAL XX**

Typical Range: CYL(#1 to # of cylinders) CAL(0 TO 99)

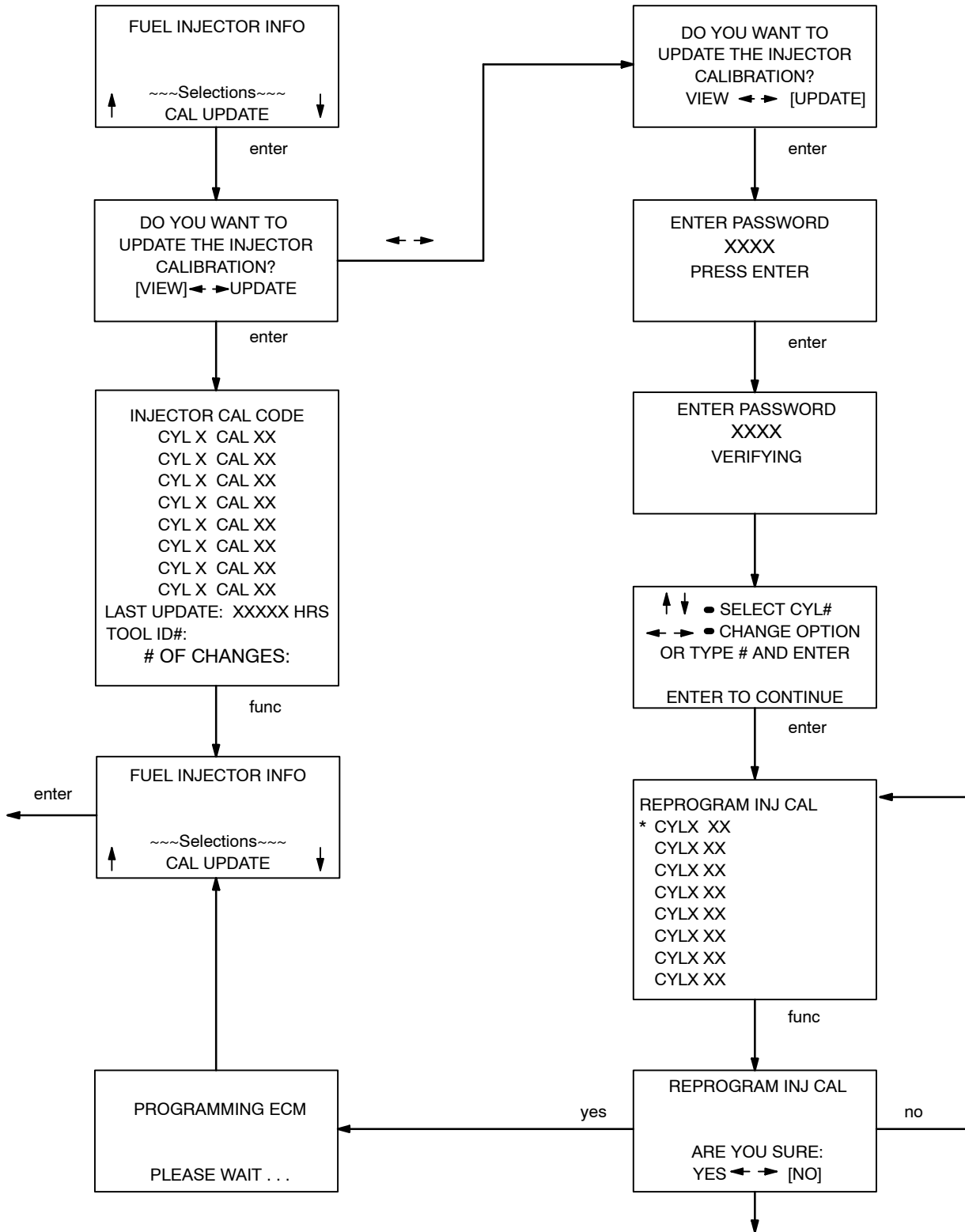

FIGURE 11

Section 10

DIAGNOSTIC DATA READER INFORMATION (Cont'd)

E. SWITCH/LIGHT STATUS

The Switch/Light Status Menu is the set of DDEC III/IV data parameters that describe the operational (ON/OFF) status of the functions assigned to the ECM input and output connector terminals.

NOTES:

- (1) The connector cavity designations describe the physical locations of the assigned functions.
- (2) The DDR displays the assigned functions the parameter text as described in Table 1 (Vehicle Switch Input Options) and Table 2 (ECM Output Options) on page H-278.
- (3) 'N/A' will be displayed if a function number of (0 = NONE) has been assigned to any of the connector cavities.
- (4) 'ON' indicates that the input switch or output function is active.

ECM INPUT SWITCHES

Parameter [7]: **G1** -----

Definition: Indicates the operational status of the switch input at vehicle connector cavity G1 (diagnostic request switch).

Typical Range: ON or OFF

Parameter [13]: **CHECK ENGINE LT**

Definition: Indicates the operational status of the check engine light.

Typical Range: ON or OFF

Parameter [14]: **STOP ENGINE LT**

Definition: Indicates the operational status of the check gauges light.

Typical Range: ON or OFF

Parameter [22]: **A1** -----

Definition: Indicates the operational status of the output at the vehicle connector cavity A1 (engine brake enable).

Typical Range: ON or OFF

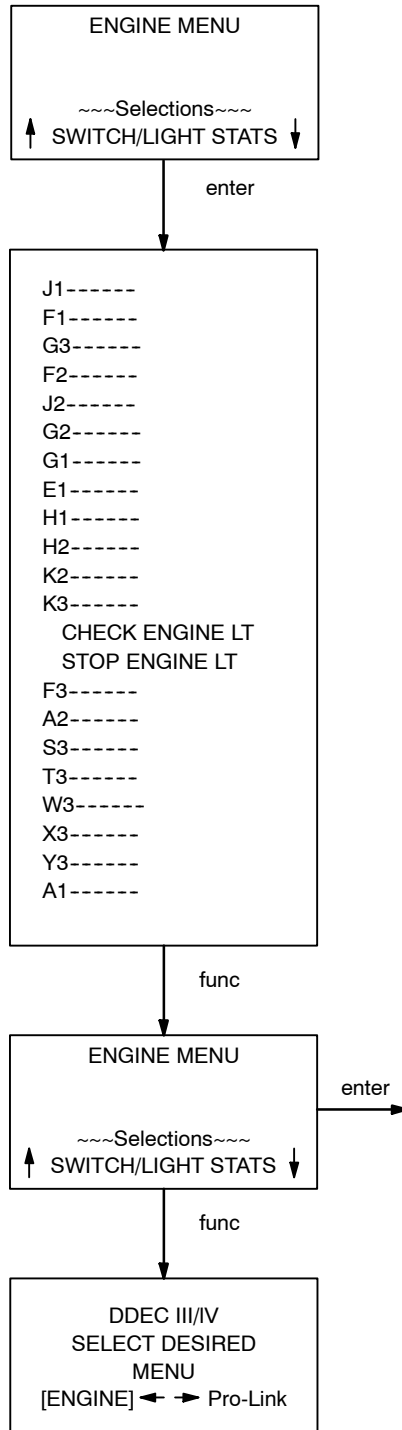

FIGURE 12

Section 10
DIAGNOSTIC DATA READER INFORMATION (Cont'd)

F. MID MESSAGES BEING RECEIVED

This menu selection indicates the Message Identifiers (MIDs) that the DDEC III/IV has acknowledged as received.

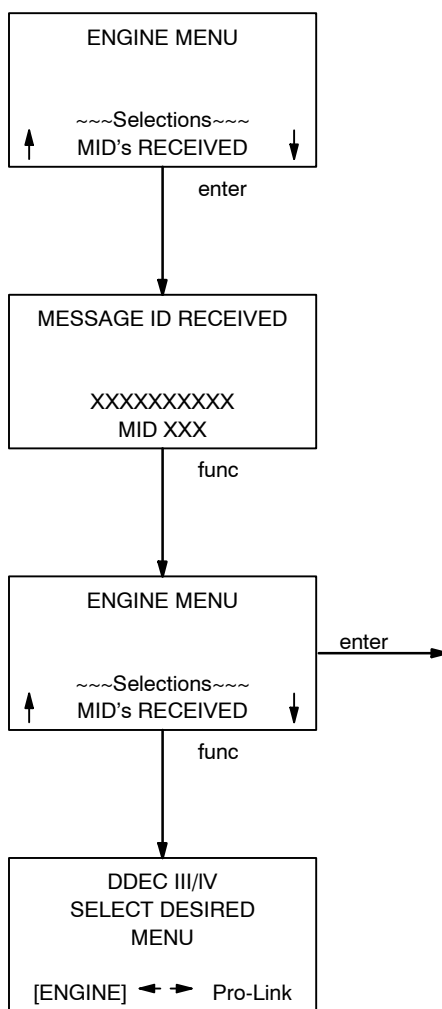
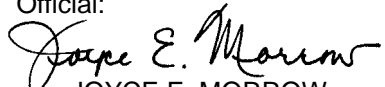

FIGURE 13

By Order of the Secretary of the Army:

GEORGE W. CASEY, JR.
General, United States Army
Chief of Staff

Official:

JOYCE E. MORROW
Administrative Assistant to the
Secretary of the Army
0702305

Distribution:

To be distributed in accordance with the initial distribution number (IDN) 380754,
requirements for TM 9-2320-360-20-3.

RECOMMENDED CHANGES TO PUBLICATIONS AND BLANK FORMS For use of this form, see AR 25-30; the proponent agency is ODISC4.						Use Part II (<i>reverse</i>) for Repair Parts and Special Tool Lists (RPSTL) and Supply Catalogs/Supply Manuals (SC/SM).	DATE Date you filled out this form.
TO: (<i>Forward to proponent of publication or form</i>) (<i>Include ZIP Code</i>) AMSTA-LC-LPIT / TECH PUBS, TACOM-RI 1 Rock Island Arsenal Rock Island, IL 61299-7630						FROM: (<i>Activity and location</i>) (<i>Include ZIP Code</i>) Your mailing address	
PART I – ALL PUBLICATIONS (EXCEPT RPSTL AND SC/SM) AND BLANK FORMS							
PUBLICATION/FORM NUMBER TM 9-2320-360-20-3						DATE 31 May 2007	TITLE Heavy Equipment Transporter, M1070, Unit Maintenance
ITEM NO.	PAGE NO.	PARA-GRAPH	LINE NO. *	FIGURE NO.	TABLE NO.	RECOMMENDED CHANGES AND REASON (Provide exact wording of recommended changes, if possible).	
	0004 00-2	4-7				Wrong POC is listed.	
							
<i>*Reference to line numbers within the paragraph or subparagraph.</i>							
TYPED NAME, GRADE OR TITLE Your Name				TELEPHONE EXCHANGE/AUTOVON, PLUS EXTENSION		SIGNATURE Your Signature	

TO: <i>(Forward direct to addressee listed in publication)</i> AMSTA-LC-LPIT / TECH PUBS, TACOM-RI 1 Rock Island Arsenal Rock Island, IL 61299-7630	FROM: <i>(Activity and location) (Include ZIP Code)</i> Your address	DATE Date you filled out this form
--	---	---------------------------------------

PART II – REPAIR PARTS AND SPECIAL TOOL LISTS AND SUPPLY CATALOGS/SUPPLY MANUALS

PUBLICATION NUMBER TM 9-2320-360-20-3	DATE 31 May 2007	TITLE Heavy Equipment Transporter, M1070, Unit Maintenance
--	---------------------	---

PAGE NO.	COLM NO.	LINE NO.	NATIONAL STOCK NUMBER	REFERENCE NO.	FIGURE NO.	ITEM NO.	TOTAL NO. OF MAJOR ITEMS SUPPORTED	RECOMMENDED ACTION

PART III – REMARKS *(Any general remarks or recommendations, or suggestions for improvement of publications and blank forms. Additional blank sheets may be used if more space is needed.)*

--

TYPED NAME, GRADE OR TITLE Your Name	TELEPHONE EXCHANGE/AUTOVON, PLUS EXTENSION	SIGNATURE Your Signature
---	--	-----------------------------

RECOMMENDED CHANGES TO PUBLICATIONS AND BLANK FORMS For use of this form, see AR 25-30; the proponent agency is ODISC4.						Use Part II (<i>reverse</i>) for Repair Parts and Special Tool Lists (RPSTL) and Supply Catalogs/Supply Manuals (SC/SM).	DATE
TO: (<i>Forward to proponent of publication or form</i>) (<i>Include ZIP Code</i>) AMSTA-LC-LPIT / TECH PUBS, TACOM-RI 1 Rock Island Arsenal Rock Island, IL 61299-7630						FROM: (<i>Activity and location</i>) (<i>Include ZIP Code</i>)	
PART I - ALL PUBLICATIONS (EXCEPT RPSTL AND SC/SM) AND BLANK FORMS							
PUBLICATION/FORM NUMBER TM 9-2320-360-20-3						DATE 31 May 2007	TITLE Heavy Equipment Transporter, M1070, Unit Maintenance
ITEM NO.	PAGE NO.	PARA-GRAPH	LINE NO. *	FIGURE NO.	TABLE NO.	RECOMMENDED CHANGES AND REASON (<i>Provide exact wording of recommended changes, if possible.</i>)	
<i>*Reference to line numbers within the paragraph or subparagraph.</i>							
TYPED NAME, GRADE OR TITLE				TELEPHONE EXCHANGE/AUTOVON, PLUS EXTENSION		SIGNATURE	

TO: <i>(Forward direct to addressee listed in publication)</i> AMSTA-LC-LPIT / TECH PUBS, TACOM-RI 1 Rock Island Arsenal Rock Island, IL 61299-7630	FROM: <i>(Activity and location) (Include ZIP Code)</i>	DATE
--	---	------

PART II – REPAIR PARTS AND SPECIAL TOOL LISTS AND SUPPLY CATALOGS/SUPPLY MANUALS

PUBLICATION NUMBER TM 9-2320-360-20-3	DATE 31 May 2007	TITLE Heavy Equipment Transporter, M1070, Unit Maintenance
--	---------------------	---

PAGE NO.	COLM NO.	LINE NO.	NATIONAL STOCK NUMBER	REFERENCE NO.	FIGURE NO.	ITEM NO.	TOTAL NO. OF MAJOR ITEMS SUPPORTED	RECOMMENDED ACTION

PART III – REMARKS *(Any general remarks or recommendations, or suggestions for improvement of publications and blank forms. Additional blank sheets may be used if more space is needed.)*

TYPED NAME, GRADE OR TITLE	TELEPHONE EXCHANGE/AUTOVON, PLUS EXTENSION	SIGNATURE
----------------------------	--	-----------

RECOMMENDED CHANGES TO PUBLICATIONS AND BLANK FORMS						Use Part II (<i>reverse</i>) for Repair Parts and Special Tool Lists (RPSTL) and Supply Catalogs/Supply Manuals (SC/SM).	DATE
For use of this form, see AR 25-30; the proponent agency is ODISC4.							
TO: (<i>Forward to proponent of publication or form</i>) (<i>Include ZIP Code</i>) AMSTA-LC-LPIT / TECH PUBS, TACOM-RI 1 Rock Island Arsenal Rock Island, IL 61299-7630						FROM: (<i>Activity and location</i>) (<i>Include ZIP Code</i>)	
PART I - ALL PUBLICATIONS (EXCEPT RPSTL AND SC/SM) AND BLANK FORMS							
PUBLICATION/FORM NUMBER TM 9-2320-360-20-3						DATE 31 May 2007	TITLE Heavy Equipment Transporter, M1070, Unit Maintenance
ITEM NO.	PAGE NO.	PARA-GRAPH	LINE NO. *	FIGURE NO.	TABLE NO.	RECOMMENDED CHANGES AND REASON (<i>Provide exact wording of recommended changes, if possible.</i>)	
<i>*Reference to line numbers within the paragraph or subparagraph.</i>							
TYPED NAME, GRADE OR TITLE				TELEPHONE EXCHANGE/AUTOVON, PLUS EXTENSION		SIGNATURE	

TO: <i>(Forward direct to addressee listed in publication)</i> AMSTA-LC-LPIT / TECH PUBS, TACOM-RI 1 Rock Island Arsenal Rock Island, IL 61299-7630	FROM: <i>(Activity and location) (Include ZIP Code)</i>	DATE
--	---	------

PART II - REPAIR PARTS AND SPECIAL TOOL LISTS AND SUPPLY CATALOGS/SUPPLY MANUALS

PUBLICATION NUMBER TM 9-2320-360-20-3	DATE 31 May 2007	TITLE Heavy Equipment Transporter, M1070, Unit Maintenance
--	---------------------	---

PAGE NO.	COLM NO.	LINE NO.	NATIONAL STOCK NUMBER	REFERENCE NO.	FIGURE NO.	ITEM NO.	TOTAL NO. OF MAJOR ITEMS SUPPORTED	RECOMMENDED ACTION

PART III - REMARKS *(Any general remarks or recommendations, or suggestions for improvement of publications and blank forms. Additional blank sheets may be used if more space is needed.)*

TYPED NAME, GRADE OR TITLE	TELEPHONE EXCHANGE/AUTOVON, PLUS EXTENSION	SIGNATURE
----------------------------	--	-----------

RECOMMENDED CHANGES TO PUBLICATIONS AND BLANK FORMS						Use Part II (<i>reverse</i>) for Repair Parts and Special Tool Lists (RPSTL) and Supply Catalogs/Supply Manuals (SC/SM).	DATE
For use of this form, see AR 25-30; the proponent agency is ODISC4.							
TO: (<i>Forward to proponent of publication or form</i>) (<i>Include ZIP Code</i>) AMSTA-LC-LPIT / TECH PUBS, TACOM-RI 1 Rock Island Arsenal Rock Island, IL 61299-7630						FROM: (<i>Activity and location</i>) (<i>Include ZIP Code</i>)	
PART I - ALL PUBLICATIONS (EXCEPT RPSTL AND SC/SM) AND BLANK FORMS							
PUBLICATION/FORM NUMBER TM 9-2320-360-20-3					DATE 31 May 2007	TITLE Heavy Equipment Transporter, M1070, Unit Maintenance	
ITEM NO.	PAGE NO.	PARA-GRAPH	LINE NO. *	FIGURE NO.	TABLE NO.	RECOMMENDED CHANGES AND REASON (<i>Provide exact wording of recommended changes, if possible.</i>)	
<i>*Reference to line numbers within the paragraph or subparagraph.</i>							
TYPED NAME, GRADE OR TITLE				TELEPHONE EXCHANGE/AUTOVON, PLUS EXTENSION		SIGNATURE	

TO: <i>(Forward direct to addressee listed in publication)</i> AMSTA-LC-LPIT / TECH PUBS, TACOM-RI 1 Rock Island Arsenal Rock Island, IL 61299-7630	FROM: <i>(Activity and location) (Include ZIP Code)</i>	DATE
--	---	------

PART II - REPAIR PARTS AND SPECIAL TOOL LISTS AND SUPPLY CATALOGS/SUPPLY MANUALS

PUBLICATION NUMBER TM 9-2320-360-20-3	DATE 31 May 2007	TITLE Heavy Equipment Transporter, M1070, Unit Maintenance
--	---------------------	---

PAGE NO.	COLM NO.	LINE NO.	NATIONAL STOCK NUMBER	REFERENCE NO.	FIGURE NO.	ITEM NO.	TOTAL NO. OF MAJOR ITEMS SUPPORTED	RECOMMENDED ACTION

PART III - REMARKS *(Any general remarks or recommendations, or suggestions for improvement of publications and blank forms. Additional blank sheets may be used if more space is needed.)*

TYPED NAME, GRADE OR TITLE	TELEPHONE EXCHANGE/AUTOVON, PLUS EXTENSION	SIGNATURE
----------------------------	--	-----------

THE METRIC SYSTEM AND EQUIVALENTS

LINEAR MEASURE

1 Centimeter = 10 Millimeters = 0.01 Meters = 0.3937 Inches
 1 Meter = 100 Centimeters = 1000 Millimeters = 39.37 Inches
 1 Kilometer = 1000 Meters = 0.621 Miles

SQUARE MEASURE

1 Sq Centimeter = 100 Sq Millimeters = 0.155 Sq Inches
 1 Sq Meter = 10,000 Sq Centimeters = 10.76 Sq Feet
 1 Sq Kilometer = 1,000,000 Sq Meters = 0.386 Sq Miles

WEIGHTS

1 Gram = 0.001 Kilograms = 1000 Milligrams = 0.035 Ounces
 1 Kilogram = 1000 Grams = 2.2 Lb
 1 Metric Ton = 1000 Kilograms = 1 Megagram = 1.1 Short Tons

CUBIC MEASURE

1 Cu Centimeter = 1000 Cu Millimeters = 0.06 Cu Inches
 1 Cu Meter = 1,000,000 Cu Centimeters = 35.31 Cu Feet

LIQUID MEASURE

1 Milliliter = 0.001 Liters = 0.0338 Fluid Ounces
 1 Liter = 1000 Milliliters = 33.82 Fluid Ounces

TEMPERATURE

$5/9 (°F - 32) = °C$
 212° Fahrenheit is equivalent to 100° Celsius
 90° Fahrenheit is equivalent to 32.2° Celsius
 32° Fahrenheit is equivalent to 0° Celsius
 $9/5 C° + 32 = F°$

APPROXIMATE CONVERSION FACTORS

<u>TO CHANGE</u>	<u>TO</u>	<u>MULTIPLY BY</u>
Inches	Centimeters	2.540
Feet	Meters	0.305
Yards	Meters	0.914
Miles	Kilometers	1.609
Square Inches	Square Centimeters	6.451
Square Feet	Square Meters	0.093
Square Yards	Square Meters	0.836
Square Miles	Square Kilometers	2.590
Acres	Square Hectometers	0.405
Cubic Feet	Cubic Meters	0.028
Cubic Yards	Cubic Meters	0.765
Fluid Ounces	Milliliters	29.573
Pints	Liters	0.473
Quarts	Liters	0.946
Gallons	Liters	3.785
Ounces	Grams	28.349
Pounds	Kilograms	0.454
Short Tons	Metric Tons	0.907
Pound-Feet	Newton-Meters	1.356
Pounds per Square Inch	Kilopascals	6.895
Miles per Gallon	Kilometers per Liter	0.425
Miles per Hour	Kilometers per Hour	1.609

<u>TO CHANGE</u>	<u>TO</u>	<u>MULTIPLY BY</u>
Centimeters	Inches	0.394
Meters	Feet	3.280
Meters	Yards	1.094
Kilometers	Miles	0.621
Square Centimeters	Square Inches	0.155
Square Meters	Square Feet	10.764
Square Meters	Square Yards	1.196
Square Kilometers	Square Miles	0.386
Square Hectometers	Acres	2.471
Cubic Meters	Cubic Feet	35.315
Cubic Meters	Cubic Yards	1.308
Milliliters	Fluid Ounces	0.034
Liters	Pints	2.113
Liters	Quarts	1.057
Liters	Gallons	0.264
Grams	Ounces	0.035
Kilograms	Pounds	2.205
Metric Tons	Short Tons	1.102
Newton-Meters	Pound-Feet	0.738
Kilopascals	Pounds per Square Inch	0.145
Kilometers per Liter	Miles per Gallon	2.354
Kilometers per Hour	Miles per Hour	0.621

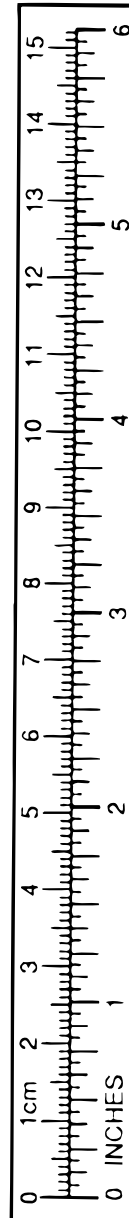

PIN: 075658-000